

Main characteristics

- Optimized mechanical structure
- Strokes from 50 to 2500 mm
- Wide range of connectors for the electrical connection
- Rod, nipple, exagonal flange AISI 316
- Power supply 10...32 Vdc
- Resistance to vibration (DIN IEC68T2/6 12g)
- Protection IP67
- Work temperature: -30°...+90°C
- Synchronous Serial Interface direct to controllers
- Output data resolution available from 20 to 40µm
- Data format: binary or Gray code; incremental/decremental
- Electromagnetic compatibility EMC 2014/30/EU
- Compliant to the directive RoHS 2011/65/EU

Contactless linear position transducer with HYPERWAVE magnetostrictive technology with RS422-SSI digital output interface. Housing closure with removable ring nut to allow the whole electronics and sensing element replacement. The absence of electrical contact on the cursor eliminates all wear and guarantees almost unlimited life.

High accuracy of the measurement with reference to the non linearity, repeatability and hysteresis. High resistance to vibrations, mechanical shocks for use in a harsh industrial environment.

TECHNICAL DATA

Model	from 50 to 2500 mm
Measurement taken	Displacement
Position read sampling time (typical)	1 ms
Shock test DIN IEC68T2-27	100g - 11ms - single shock
Vibrations DIN IEC68T2-6	12g / 10...2000Hz
Displacement speed	≤ 10 m/s
Max acceleration	≤ 100 m/s ² displacement
Output data resolution available	20, 40µm
Cursor (see note)	Floating magnet
Working temperature	-30...+90°C
Storage temperature	-40...+100°C
Coefficient of temperature	20ppm F.S./°C
Protection	IP67
Operative pressure	350 bar (pic max. 500 bar)

ELECTRICAL DATA

Output signal	Synchronous Serial (SSI); Binary/Gray; Incremental/Decremental
Data length	24 - 25 bit
Nominal power supply	10... 32 Vdc
Max. power ripple	1Vpp
Max. input	50mA
Output load	RS422/485 standard
Electrical isolation	500 V (*) (D.C. supply / earth)
Protection against polarity inversion	Yes
Protection against overvoltage	Yes
Self-resetting internal fuse	Yes

(*) it includes a 50V 2J voltage suppressor

Note: For multi-cursor versions, the cursors have to work under the same distance and temperature conditions

ELECTRICAL / MECHANICAL DATA

Model		50	75	100	130	150	175	200	225	250	300	350	360	400	450	500	550	600	650	700	750	800	850	900	950	1000	1100	1200	1250	1300	1400	1500	
														1750	2000	2250	2500																
Electrical stroke (E.S)	mm	Model																															
Independent linearity	± %F.S.	± 0,02 %FS (min ± 0,060mm)																															
Max. dimensions (A)	mm	< 1250 mm = Model + 178.2mm ; ≥ 1250mm = Model +183.2mm																															
Repeatability	mm	< 0,01 (limited by the resolution of the output value)																															
Hysteresis		< ± 0,005% FS (min 0,010 mm)																															
Sampling time	ms	1 (for stroke from 1000) 2 (for stroke from 1100 to 2000) 4 (for stroke >2000)																															

MECHANICAL DIMENSIONS

Strokes from 50 to 1000 mm

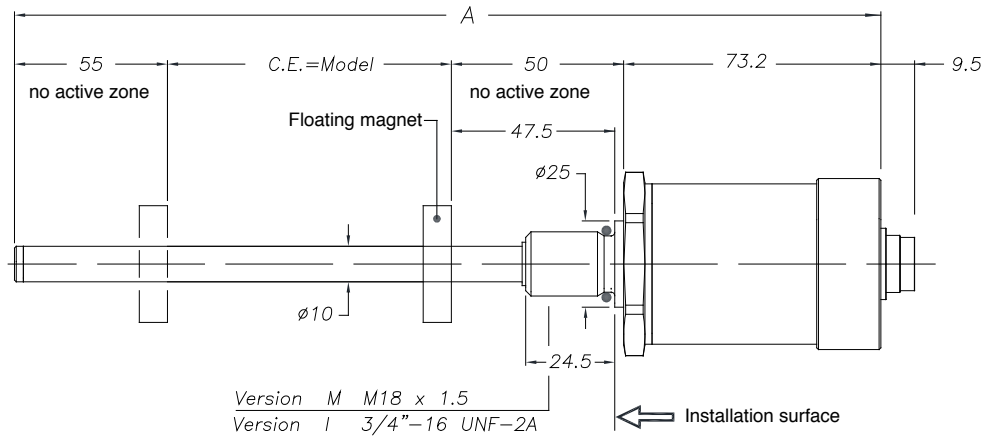

Strokes from 1100 to 2500 mm

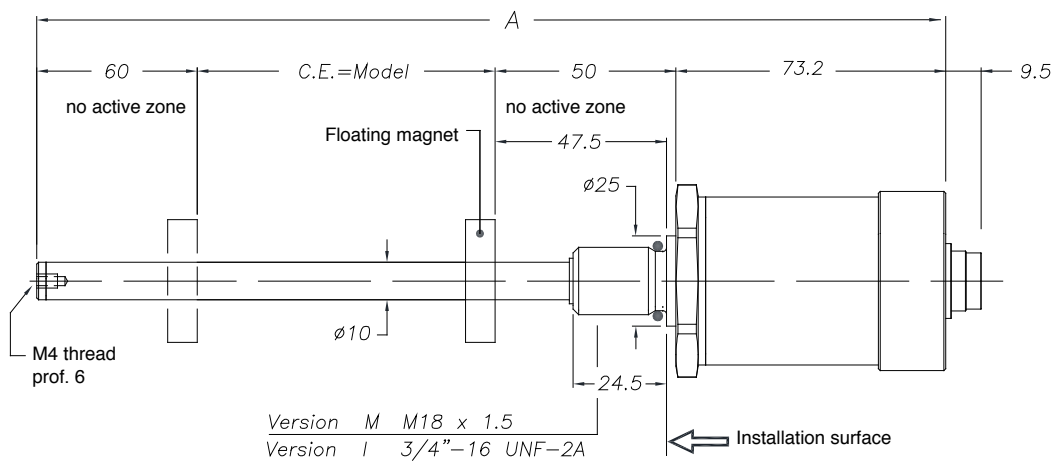

WRP-S-F/R cable output

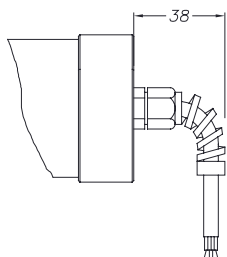

WRP-S-B/D connector output

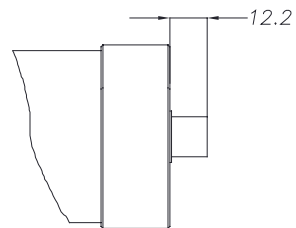

MOUNTING INSIDE A CYLINDER

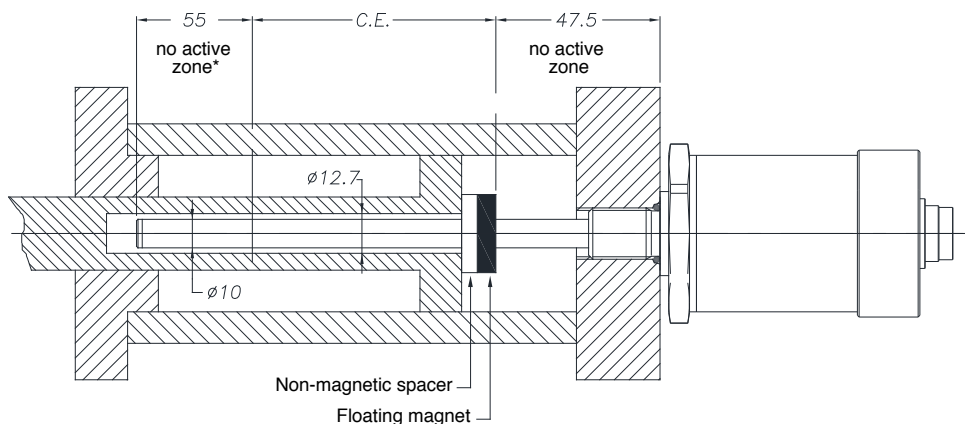

* for stroke up to 1000 mm (included) – over 1000 mm, the non-active zone becomes 60 mm because the tip includes a M4 threaded hole

INSTALLATION INSIDE A CYLINDER

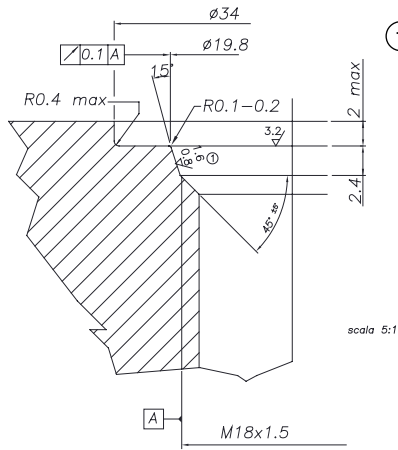

- ① **THREAD M18x1,5**
 The sealing surface must be free from scratches longitudinal or spiral
 Ro 1.6 μm for sealing with NON-pulsating pressure
 Ro 0.8 μm for seals with pulsating pressure

Suggested o-ring:
 PARKER 6-349 15,4x2,1
 Material: Viton 90° Shore-A
 Mixes: PARKER N552-90

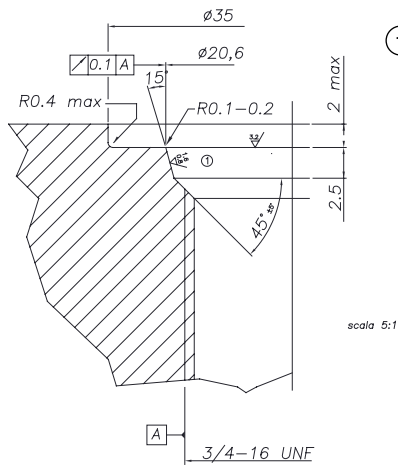
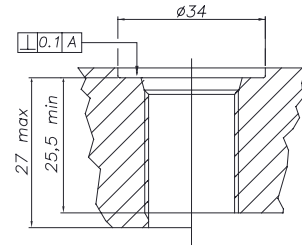

- ① **THREAD 3/4"-16UNF**
 The sealing surface must be free from scratches longitudinal or spiral
 Ro 1.6 μm for sealing with NON-pulsating pressure
 Ro 0.8 μm for seals with pulsating pressure

Suggested o-ring:
 PARKER 3-908 16,36x2,21
 Material: Viton 90° Shore-A
 Mixes: PARKER N552-90

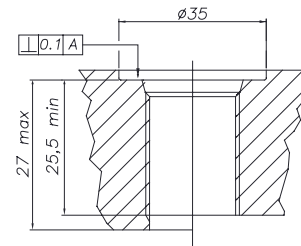

ELECTRICAL CONNECTIONS

OUTPUT WRP-S-B

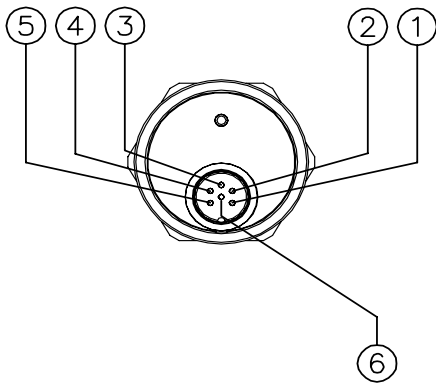

OUTPUT WRP-S-D

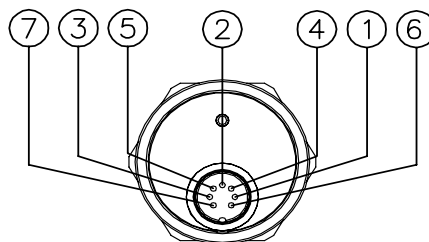

OUTPUT WRP-S-F/R

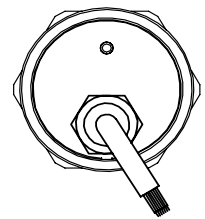

Function	WRP-S-B	WRP-S-D	WRP-S-F	WRP-S-R
	6-pin M16	7-pin M16	Cable output	PUR cable output
Data -	1	1	Orange	Pink
Data +	2	2	Orange / White	Blue
Clock +	3	3	Green / White	Gray
Clock -	4	4	Green	Yellow
Power supply +	5	5	Blue / White	Green
Power supply GND	6	6	Blue	Brown
n.c.	-	7	-	-
n.c.	-	-	-	-

GROUNDING WRP-S

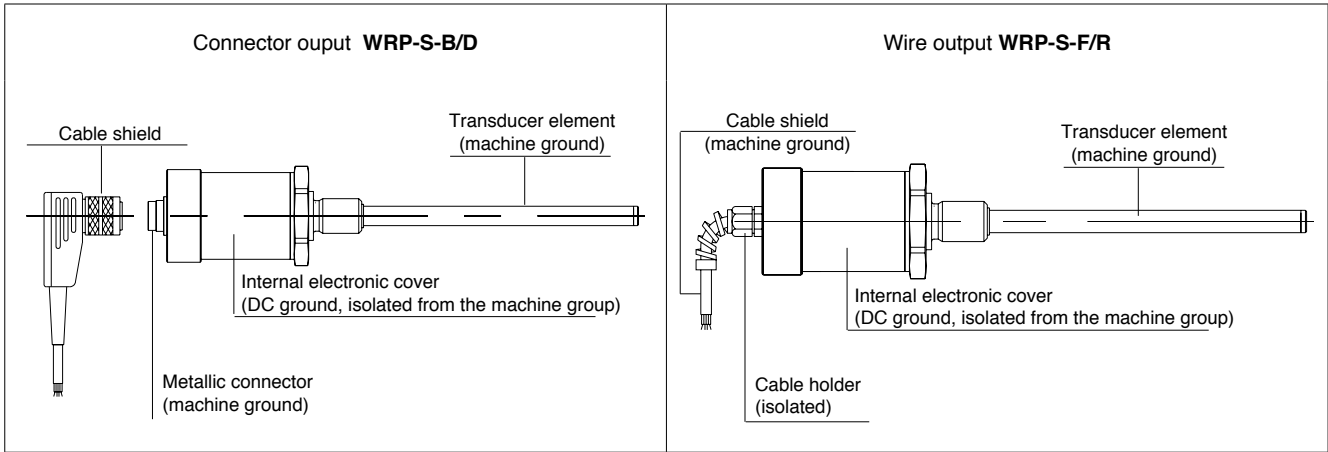

ORDER CODE

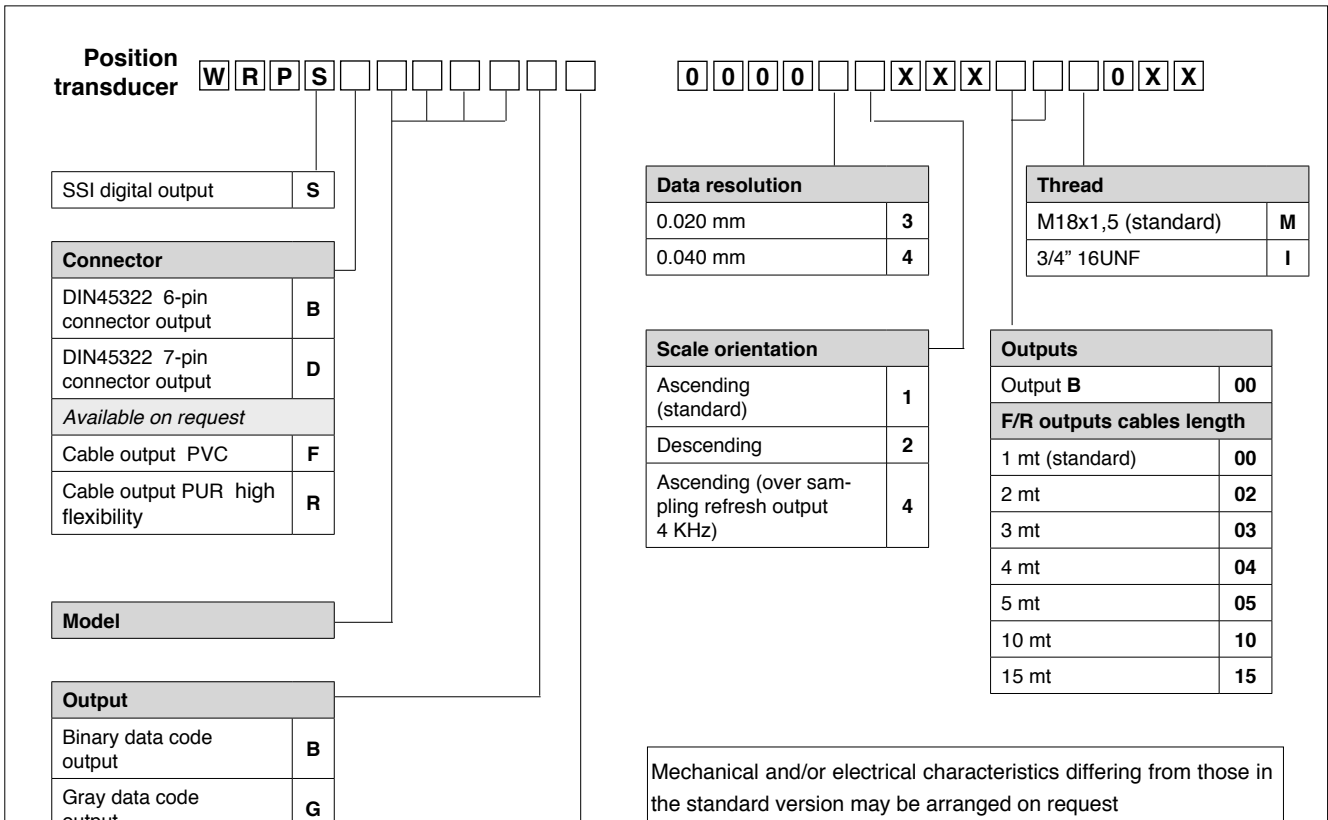

► **Included in the supply**

- Series WR position transducer
- OR 15.4x2.1 thread M18x1.5 code: **GUA064**
- OR 16.36x2.21 thread 3/4" - 16 UNF code: **GUA065**

► **Magnetic cursors must be ordered separately**

Ex.: **WRP-S-B-0400-B-3 000011XXX00M0XX**

Transducer model WRP, SSI output, connector B, model 400mm, thread M18x1,5, binary data code output, data length 24 bit, system resolution 0.005mm, scale orientation ascending.

FLOATING CURSOR



Cursors	
Cursor Diameter 32.8	095
Cursor Diameter 32.8 with 90° slit	096
Cursor Diameter 25.4	097
Floating cursor for liquids with hole diameter 12	098

The **PCUR095** is supplied with:
 N° 8 Brass nuts M4
 N° 8 Brass washers D4
 N° 4 Brass screws M4x25

The **PCUR096** is supplied with:
 N° 4 Brass nuts M4
 N° 4 Brass washers D4
 N° 2 Brass screws M4x25

Dimensions	A	B	C	D	Thickness
PCUR095	32.8	13.5	23.9	-	7.9
PCUR096				11	
PCUR097	25.4	13.5	-	-	

Model	PCUR098	
Length A	mm	52.4
Diameter B (hole)	mm	12
Diameter C	mm	44
Material	AISI 316	

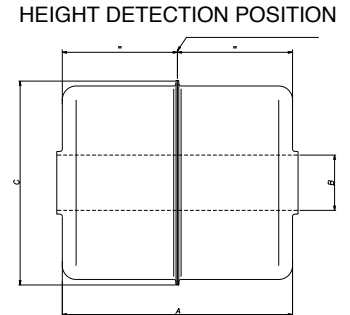
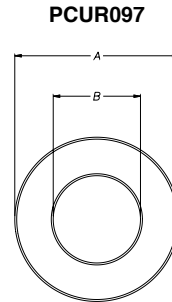
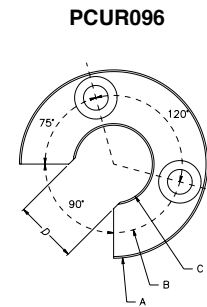
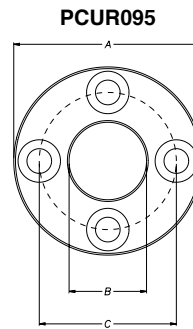

Note: PCUR098 is supplied with kit PKIT036 for floating cursor for liquids.

OPTIONAL CONNECTORS

For **WRP-S-B** M16 thread connector

Codes: **CON021** 6-pin
CON022 6-pin
CON023 6-pin

Connector extraction length: 10mm

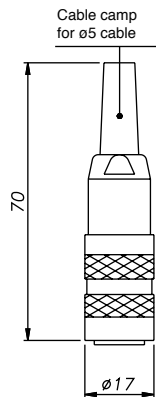

CON021
IP40 - EMC

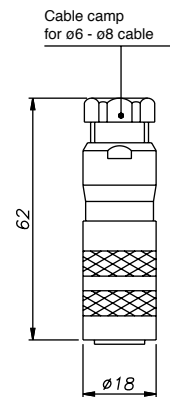

CON022
IP67 - EMC

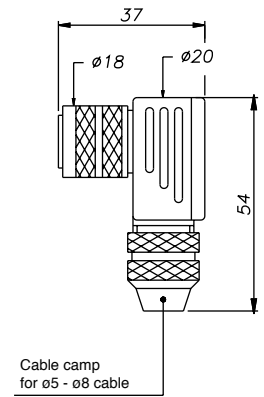

CON023
IP67 - EMC

Note:

The IP rating specified in this document normally applies with the suitable female connector plugged-in and properly wired.

Electrical installation requirements and Conformity certificate are available on our web site: www.gefran.com

GEFRAN spa reserves the right to make aesthetic or functional changes at any time and without notice

GEFRAN

GEFRAN spa
 via Sebina, 74
 25050 PROVAGLIO D'ISEO (BS) - ITALIA
 ph. 0309888.1 - fax. 0309839063
<http://www.gefran.com>

DTS_WRP-S_02-2019_ENG