

### Main applications

- Plastics extrusion lines and injection moulding machines
- Packing and packaging machines
- Polymerization plant for synthetic fibre production
- Rubber moulding machinery
- Driers for ceramics and components for the building industries
- Chemical and pharmaceutical industries
- Industrial electric furnaces
- Food processing plants



### Main features

- Alternating current solid state relay
- Zero crossing switching
- Copper/semiconductor coupling technology
- 10, 15, 20, 25, 40, 50, 60, 90, and 120 Arms nominal current
- Non-repetitive voltage: up to 1200Vp
- Nominal Voltage: up to 530VCArms
- Input control range: 5...32 Vcc
- 4000 Vrms optoinsulation (input-output)
- Green LED, drive input signal indicator
- MOV (varistors)

### PROFILE

Zero crossing relay with antiparallel thyristor output is the most used solid state relay in industrial applications. "Zero crossing" relay is energised when voltage meets the zero point and disenergised when current meets the zero point, depending on the signal control on the input circuit. For applications with merely resistive loads, "T" version is available with TRIAC output.

When the relay has to stand high currents for a long period, it is necessary to grant a proper dissipation and an adequate electrical connection between relay terminals and the load.

Use the relè with an opportune heatsink (see section accessories).

Varistors, fuses, thermostats and fans are available as fittings.

### TECHNICAL DATA

#### General features

Category of use: AC1  
 Nominal voltage  
 - 230Vac (max. range 24...280Vac)  
 - 480Vac (max. range 24...530Vac)  
 Nominal frequency: 50/60Hz  
 Non-repetitive voltage:  
 • 500Vp for model with rated voltage 230Vac  
 • for model with rated voltage 480Vac  
 Switching voltage for zero: < 20V  
 Activation time: ≤ 1/2 cycle  
 Deactivation time: ≤ 1/2 cycle  
 Potential drop at rated current: ≤ 1.4V  
 Power factor = 1

#### Control inputs

Max. input: < 10mA@32V  
 Max. reverse voltage: 36Vdc

#### GS-T10/T20/T25 (TRIAC version)

Control voltage: 5...32Vdc  
 Activation voltage: > 4,2Vdc  
 Deactivation voltage: < 2Vdc

#### GS15 ... 120A (SCR version)

Control voltage: 6...32Vdc  
 Activation voltage: > 5.1Vdc  
 Deactivation voltage: < 3Vdc

### OUTPUTS

#### GS-T10 (TRIAC version)

Nominal currents of the device with opportune heatsink in continuous work: 10A  
 Non-repetitive overcurrent t=20 ms: 30A  
 I<sup>2</sup>t for blowout: 72A<sup>2</sup>s  
 dV/dt critical with output deactivated: 500V/μs

#### GS-T20 (TRIAC version)

Nominal currents of the device with opportune heatsink in continuous work: 20A  
 Non-repetitive overcurrent t=20 ms: 50A  
 I<sup>2</sup>t for blowout: 315A<sup>2</sup>s  
 dV/dt critical with output deactivated: 500V/μs

#### GS-T25 (TRIAC version)

Nominal currents of the device with opportune heatsink in continuous work: 25A  
 Non-repetitive overcurrent t=20 ms: 50A  
 I<sup>2</sup>t for blowout: 315A<sup>2</sup>s  
 dV/dt critical with output deactivated: 500V/μs

#### GS 15 (SCR version)

Nominal currents of the device with opportune heatsink in continuous work: 15A  
 Non-repetitive overcurrent t=20 ms: 400A  
 I<sup>2</sup>t for blowout: ≤450A<sup>2</sup>s

dV/dt critical with output deactivated:  
1000V/μs

#### GS 25 (SCR version)

Nominal currents of the device with opportune heatsink in continuous work: 25A

Non-repetitive overcurrent t=20 ms: 400A  
I<sup>2</sup>t for blowout: ≤645A<sup>2</sup>s

dV/dt critical with output deactivated:  
1000V/μs

#### GS 40 (SCR version)

Nominal currents of the device with opportune heatsink in continuous work: 40A

Non-repetitive overcurrent t=20 ms: 600A  
I<sup>2</sup>t for blowout: ≤1010A<sup>2</sup>s

dV/dt critical with output deactivated:  
1000 V/μs

#### GS 50 (SCR version)

Nominal currents of the device with opportune heatsink in continuous work: 50A

Non-repetitive overcurrent t=20 ms:  
1150A

I<sup>2</sup>t for blowout: ≤6600A<sup>2</sup>s

dV/dt critical with output deactivated:  
1000 V/μs

#### GS 60 (SCR version)

Nominal currents of the device with opportune heatsink in continuous work: 60A

Non-repetitive overcurrent t=20  
ms:1150A

I<sup>2</sup>t for blowout: ≤6600A<sup>2</sup>s

dV/dt critical with output deactivated:  
1000 V/μs

#### GS 75 (SCR version)

Nominal currents of the device with opportune heatsink in continuous work: 75A

Non-repetitive overcurrent t=20  
ms:1300A

I<sup>2</sup>t for blowout: ≤8000A<sup>2</sup>s

dV/dt critical with output deactivated:  
1000 V/μs

#### GS 90 (SCR version)

Nominal currents of the device with opportune heatsink in continuous work: 90A

Non-repetitive overcurrent t=20  
ms:1500A

I<sup>2</sup>t for blowout: ≤11200A<sup>2</sup>s

dV/dt critical with output deactivated:  
1000 V/μs

#### GS 120 (SCR version)

Nominal currents of the device with opportune heatsink in continuous work: 120A

Non-repetitive overcurrent t=20 ms:1500A  
I<sup>2</sup>t for blowout: ≤11200A<sup>2</sup>s

dV/dt critical with output deactivated:  
1000V/μs

#### Isolation

Rated isolation voltage input/output :  
2500VAC rms TRIAC version  
4000VAC rms SCR version

### Thermal features

#### GS-T 10

Junction temperature: ≤ 125°C  
Rth junction/case: ≤ 2.5 K/W  
Rth junction/ambient: ≤ 12.5 K/W

#### GS-T 20

Junction temperature: ≤ 125°C  
Rth junction/case: ≤ 2 K/W  
Rth junction/ambient: ≤ 12.5 K/W

#### GS-T 25

Junction temperature: ≤ 125°C  
Rth junction/case: ≤ 2 K/W  
Rth junction/ambient: ≤ 12.5 K/W

#### GS 15

Junction temperature: ≤ 125°C  
Rth junction/case: ≤ 2.0 K/W  
Rth junction/ambient: ≤ 12.5 K/W

#### GS 25

Junction temperature: ≤ 125°C  
Rth junction/case: ≤ 1.25 K/W  
Rth junction/ambient: ≤ 12 K/W

#### GS 40

Junction temperature: ≤ 125°C  
Rth junction/case: ≤ 0.65 K/W  
Rth junction/ambient: ≤ 12 K/W

#### GS 50

Junction temperature: ≤ 125°C  
Rth junction/case: ≤ 0.35 K/W  
Rth junction/ambient: ≤ 12 K/W

#### GS 60

Junction temperature: ≤ 125°C  
Rth junction/case: ≤ 0.35 K/W  
Rth junction/ambient: ≤ 12 K/W

#### GS 75

Junction temperature: ≤ 125°C  
Rth junction/case: ≤ 0.3 K/W  
Rth junction/ambient: ≤ 12 K/W

#### GS 90

Junction temperature: ≤ 125°C  
Rth junction/case: ≤ 0.3 K/W  
Rth junction/ambient: ≤ 12 K/W

#### GS 120

Junction temperature: ≤ 125°C  
Rth junction/case: ≤ 0.25 K/W  
Rth junction/ambient: ≤ 12 K/W

### Solid State Relay Dissipated Power Calculation

Single-phase relay

Pd = 1.4 \* IRMS [W] (for GS)

Pd = 1.6 \* IRMS [W] (for GS-T)

IRMS = single-phase load current

### Heatsink Thermal Resistance Calculation

Rth = (90°C - max amb. T) / Pd

where Pd = dissipated power

Max. amb. T = max air temperature inside the electrical cabinet.

Use a heatsink with thermal resistance inferior to the calculated one (Rth).

### Ambient conditions

• **Working temperature:** 0 to 80°C.

• **Max. relative humidity:** 50% to 40°C

• **Max. installation altitude:**

2000m asl

• **Pollution level 3**

• **Storage temperature:** -20..85°C

### Installation notes

- The heat sink must be grounded.

- The device must be protected by an appropriate high-speed fuse (accessory).

- Applications with solid state power units must also include an automatic safety switch to cut out the load power line.

- Protect the solid state relay by using an appropriate heat sink (accessory).

The heat sink must be sized according to room temperature and load current (see the technical documentation).

- Procedure for mounting on heat sink:

The module-heat sink contact surface must have a maximum planarity error of 0.05mm. and maximum roughness of 0.02mm. The fastening holes on the heat sink must be threaded and counter-sunk.

Attention: spread 1 gram of thermoconductive silicone (we recommend DOW CORNING 340 HeatSink) on the dissipative metal surface of the module.

The surfaces must be clean and there must be no impurities in the thermoconductive paste.

Alternately tighten the two fastening screws until reaching a torque of 0.60 Nm for the M4 screws and 0.75 Nm for the M5 screws.

Wait 30 minutes for any excess paste to drain.

Alternately tighten the two fastening screws until reaching a torque of 1.2 Nm for the M4 screws and 1.5 Nm for the M5 screws.

We advise you to randomly check for proper installation by dismantling the module to make sure there are no air bubbles under the copper plate.

### Limits of use

• dissipation of thermal power of device with restrictions on temperature of installation site.

• requires exchange with outside air or an air conditioner to transfer dissipated power outside the panel.

• installation restrictions (distances between devices to guarantee dissipation by natural convection).

• max. voltage limits and derivative of transients in line, for which the solid state unit has internal protection devices (depending on model).

• presence of dispersion current < 3mA for SCR version GS

< 4mA for TRIAC version GS (max. value with rated voltage and junction temperature of 125°C).

**DESCRIPTION OF FACEPLATE / DIMENSIONS AND MOUNTING MEASUREMENTS**

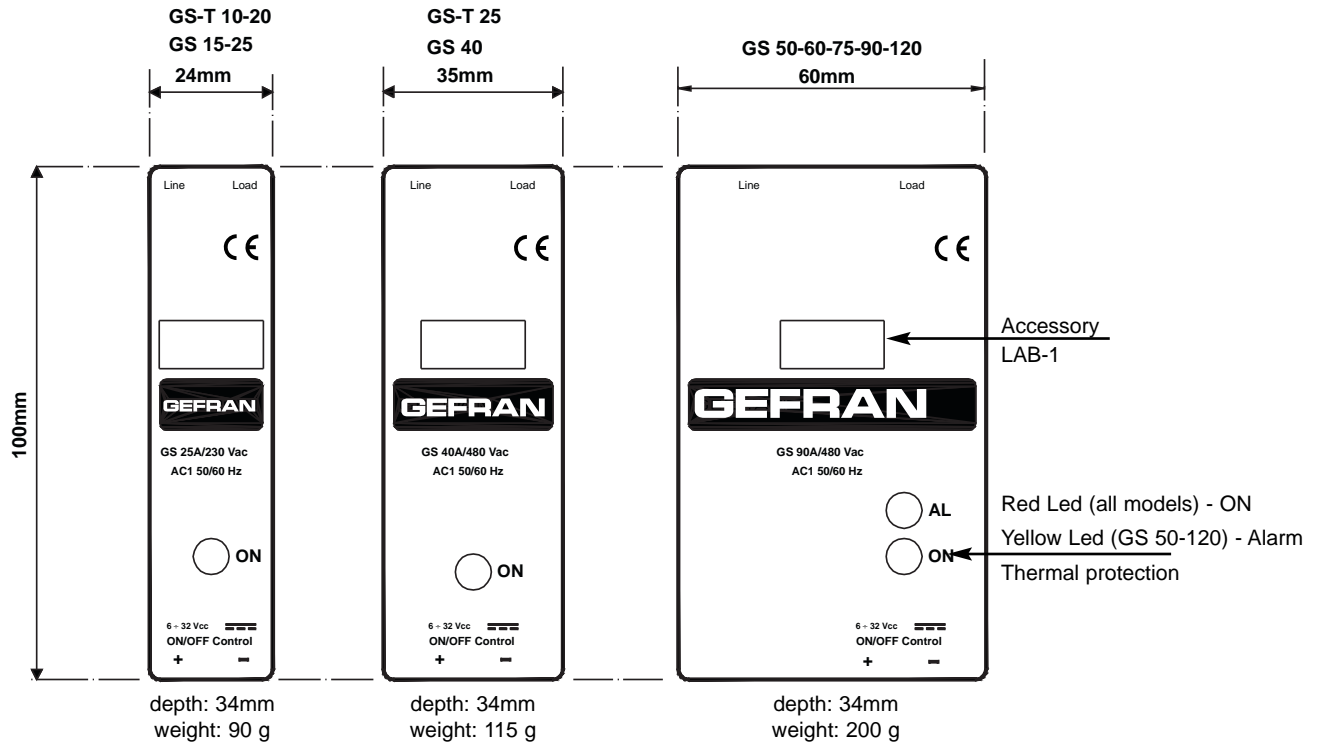

**TEMPLATE DIMENSIONS**

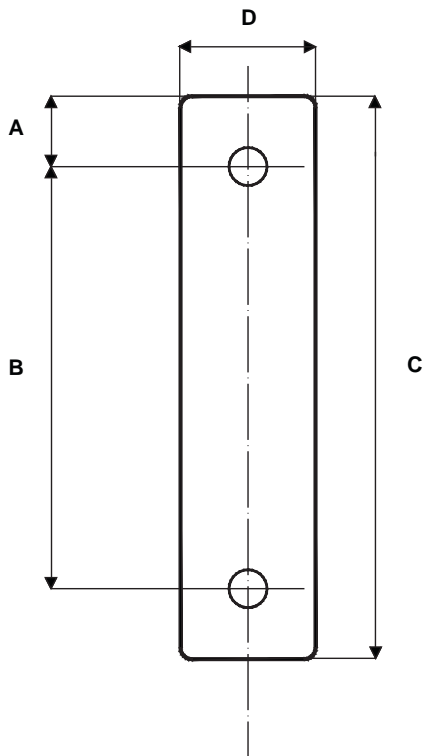

	A(mm)	B(mm)	C(mm)	D(mm)	
GS 15-25 GS-T 10-20	18	47.5	100	24	M4
GS 40 / GS-T 25	20	47.5	100	35	M4
GS 50-60-75-90-120	26	47.5	100	60	M5

**TYPE OF OPERATION**

**Control from logic output in voltage**

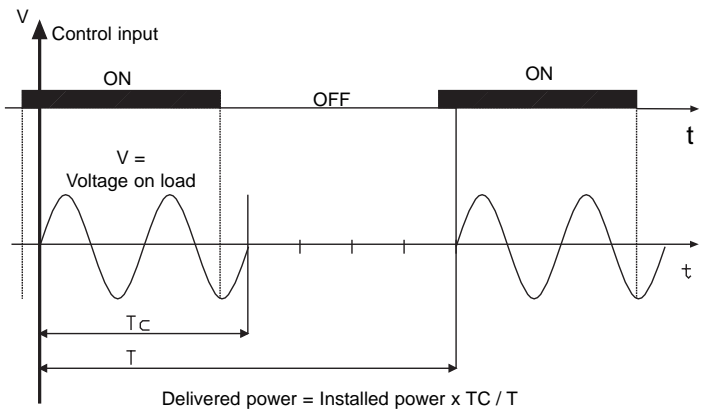

**GS thermal protection**

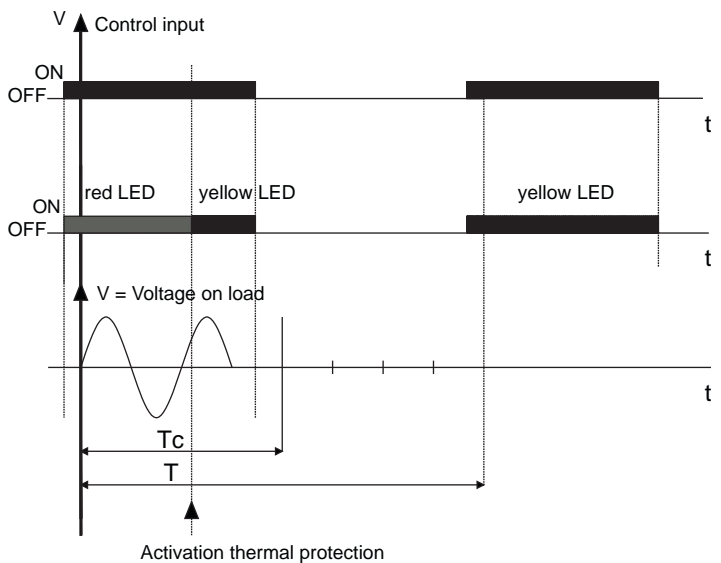

**CONNECTION EXAMPLES**

Single-phase connection

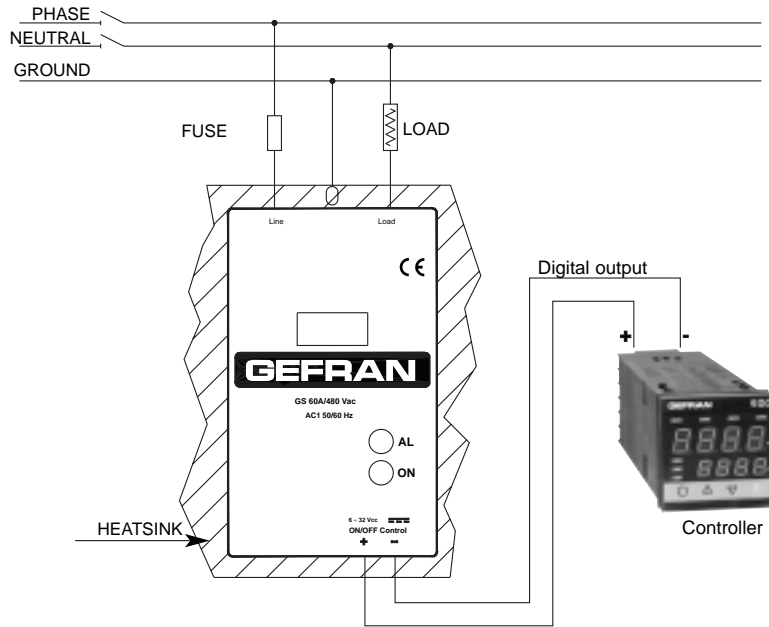

Three-phase Star connection with neutral

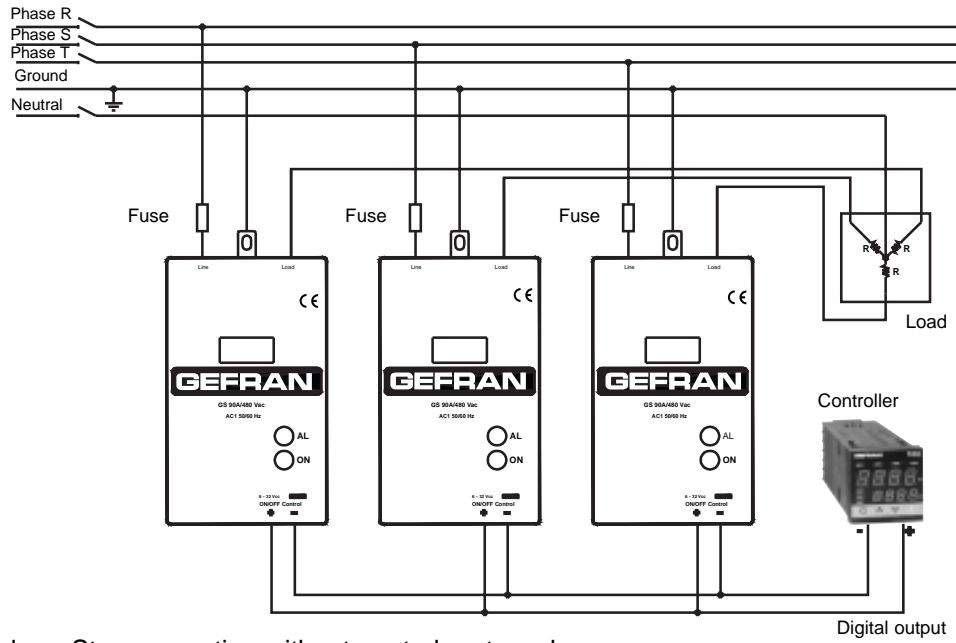

Three-phase Triangle or Star connection without neutral on two phases

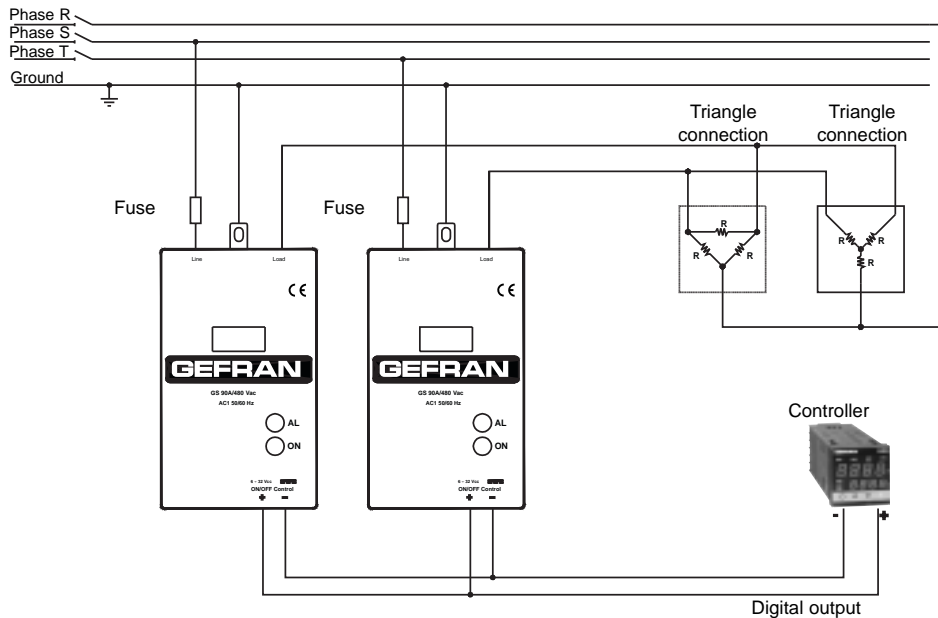

## TABLE OF TERMINALS AND CONDUCTORS

Size	CONTROL TERMINAL			POWER TERMINAL			FIXING SCREWS
	Contact area (WxD) screw	Type of pre-isolated wire terminal	Max Sect.** conductor tightening torque	Contact area (WxD) screw	Type of pre-isolated wire terminal	Max Sect.** conductor tightening torque	
10/15/20A	6,4x9 M3	Eye/fork Faston type conn*	6mm <sup>2</sup> 0.6Nm Max	6,4x9 M3	Eye/fork / conn tipo Faston*	6mm <sup>2</sup> 0.4-0.6 Nm	M4 1.2 Nm
25A(GS)	6,4x9 M3	Eye/fork Faston type conn*	6mm <sup>2</sup> 0.6Nm Max	6,4x9 M3	Eye/fork	6mm <sup>2</sup> 0.4-0.6 Nm	M4 1.2 Nm
40/25A(GS-T)	6,3x9 M3	Eye/fork tip	2,5mm <sup>2</sup> 0.6Nm Max	12x12 M5	Eye/fork	16mm <sup>2</sup> 1.5-2.2 Nm	M4 1.2 Nm
50/60A	6,3x9 M3	Eye/fork tip	2,5mm <sup>2</sup> 0.6Nm Max	16x18 M6	Eye/fork	50mm <sup>2</sup> 3.5-6 Nm	M5 1.5 Nm
75A	6,3x9 M3	Eye/fork tip	2,5mm <sup>2</sup> 0.6Nm Max	16x18 M6	Eye/fork	50mm <sup>2</sup> 3.5-6 Nm	M5 1.5 Nm
90A	6,3x9 M3	Eye/fork tip	2,5mm <sup>2</sup> 0.6Nm Max	16x18 M6	Eye/fork	50mm <sup>2</sup> 3.5-6 Nm	M5 1.5 Nm
120A	6,3x9 M3	Eye/fork tip	2,5mm <sup>2</sup> 0.6Nm Max	16x18 M6	Eye/fork	50mm <sup>2</sup> 3.5-6 Nm	M5 1.5 Nm

(\*) Female faston (for insertion, remove the M3 screw by making the nut re-enter the seat in the holder)

(\*\*)The max. sections specified refer to unipolar copper wires isolated in PVC.

## ACCESSORIES

A wide range of accessories is available (including fuses and fuse holders, heat sinks, ID plates and thermostats).

To choose accessories, see the section "Solid state relays - Accessories."

## ORDER CODE

<b>Model</b>		GS-T	/	230
TRIAC version		<b>GS-T</b>		
<b>Rated current</b>				
10Aac		<b>10</b>		
20Aac		<b>20</b>		
25Aac		<b>25</b>		
<b>Rated voltage</b>				
230Vac		<b>230</b>		

<b>Model</b>		GS	/	
Version with double SCR		<b>GS</b>		
<b>Rated current</b>				
15Aac		<b>15</b>		
25Aac		<b>25</b>		
40Aac		<b>40</b>		
50Aac		<b>50</b>		
60Aac		<b>60</b>		
75Aac		<b>75</b>		
90Aac		<b>90</b>		
120Aac		<b>120</b>		
<b>Rated voltage</b>				
230Vac		<b>230</b>		
480Vac		<b>480</b>		

Please contact GEFRAN personnel for information on availability of codes.

## •WARNINGS



**WARNING:** this symbol indicates danger.

**Read the following warnings before installing, connecting or using the device:**

- follow instructions precisely when connecting the device.
- always use cables that are suitable for the voltage and current levels indicated in the technical specifications.
- in applications with risk of damage to persons, machines or materials, you **MUST** install auxiliary alarm devices.
- it is advisable to be able to check alarm states during normal operation as well
- **DO NOT** operate the device in rooms with dangerous (flammable or explosive) atmosphere.
- During continuous operation, the heat sink can reach up to 100°C, and stays at a high temperature even after the device is turned off due to thermal inertia; therefore, **DO NOT** touch it and avoid contact with electrical wires.
- do not work on the power part without first disconnecting electrical power to the panel.
- do not remove the cover when the device is powered!

**Installation:**

- correctly ground the device using the specific terminal.
- power supply lines must be separated from device input and output lines; always check that the supply voltage matches the voltage indicated on the device label.
- avoid dust, humidity, corrosive gases and heat sources.
- respect the installation distances between one device and another (to allow for dissipation of generated heat).
- to keep air in movement, we advise you to install a fan near the GST-GS group in the electrical panel containing the GST-GSs.
- respect the indicated dissipation curves

**Maintenance:** at regular intervals, check operation of the cooling fans and clean all air ventilation filters.

- repairs must be done only by trained and specialized personnel. Cut power to the device before accessing internal parts.
- do not clean the box with solvents derived from hydrocarbons (trichloroethylene, gasoline, etc.). Using such solvents will compromise the device's mechanical reliability. Use a clean cloth moistened with ethyl alcohol or water to clean external parts in plastic.

**Service:** GEFRAN has a service department. The warranty excludes defects caused by any use not conforming to these instructions.

GEFRAN spa reserves the right to make aesthetic or functional changes at any time and without notice.



This device conforms to European Union Directive 2004/108/CE and 2006/95/CE as amended with reference to generic standards: **EN 61000-6-2** (immunity in industrial environment) **EN 61000-6-4** (emission in industrial environment) - **EN 61010-1** (safety regulations).



In Conformity with **UL508** - File: **E243386**