



Main applications

- Machine control:
 - Plastics
 - Packing
 - Wood
 - Metalworking

Main features

- 6.5" display
- Resolution 640x480 (VGA)
- Touch screen: resistive, analog
- Field bus connectivity (CANOpen, Modbus RTU, Modbus TCP)
- Ethernet 10/100 BaseT
- Fan less
- Solid State Disk (DOM)
- Programmable with:
 - Gefran Automation Builder
 - VedoWin
 - Scada



PROFILE

The GF_VEDO line of operator terminals offers a compact and economic system for machine control.

Machine cycle control [IEC1131 based Soft PLC] and graphic page display [SCADA] are integrated in a single product.

This integration provides a variety of quick and economical automation solutions.

The GF_VEDO ML 65CT is offered with a 6.5" TFT active matrix display, with resolution of 640x480 pixel (VGA).

The processor belongs to the GEODE family (32 bit), with a minimum of 128 MB to a maximum of 512 MB of RAM, depending on the operating system installed.

A extremely important feature is the complete absence of moving parts: a Compact Flash mass memory of various capacity [1GB...2GB] is used, offering maximum safety even in the presence of strong vibration.

A wide range of peripheral I/O is available:

- 1x RS485 optoisolated
- 2xEthernet 10/100 Base-T
- 4xUSB 2.0 (Host)
- Fieldbuses keyboard

- Auto-ON
 - 1xRS232
 - PS/2 Mouse and Keyboard
 - 1 x Fieldbus [optional] (CAN Layer 2)
- The product can be ordered with different operating systems already installed, such as:

- VxWorks
- Windows XP Embedded

This solution allows the creation of various automation architectures (including real time) and the use of software from other suppliers.

The GF_VEDO family includes products with display from 3.5" to 15", with or without integrated machine keyboards.

In addition "ready-to-use" application are available, such as:

- GF_PACK_EXTRUSION extrusion
- GF_PACK_INJECTION injection

TECHNICAL DATA

DISPLAY

Type:	TFT Color
No. colors:	262.144
Size:	6.5"
Resolution:	640x480 (VGA)
Luminosity:	500 cd/m ²
Contrast:	450:1

TOUCH SCREEN

Type:	Resistive, 4 leads
Life:	>1.000.000 operations
Controller:	integrated

PROCESSOR

Type:	AMD GEODE LX900
Frequency:	600 MHZ
Core:	x86

MEMORY

System memory (DRAM):	128-512 MB
Mass memory (Compact Flash):	1GB-2GB

OS SUPPORTED

VxWorks
Windows XP Embedded

GENERAL DATA

Front dimensions: 187x133mm
Drilling dimensions: 179,5x127mm
Weight: 0,9 Kg
Front panel protection: IP65
Working temperature: 0...50°C
Storage temperature: -20°C...70°C
Humidity: 5...95% non-condensing (IEC 68-2-3)
Power supply: 24Vdc \pm 25%, 20W
Certifications: CE, UL (awaiting certification)

Name: RS485
Connector: RJ10 4p4c
Optically isolated: YES
Baud rate: 9,6...115 kBaud
Name: USB1
Type: 2xUSB 2.0 HOST
Connector: Type A (500mA)
Name: USB2
Type: 2xUSB 2.0 HOST
Connector: Type A (500mA)
Name: KEY & LED
Function: Fieldbuses keyboard
Connector: RJ45 (without LEDs)
Optically isolated: NO

Name: PC-KEY
Connector: standard PS2 miniDIN 6 pin (green)
Name: FIELDBUS [optional]
Function: CAN layer 2
Connector: D-Sub 9 pin male
Name: RS232
Connector: D-Sub 9-pin male
Optoisolata: NO
Baud rate: 9,6...115 kBaud
Name: AUX
Function: future expansions

PERIPHERAL I/O

Name: ETH1
Type: Ethernet 10/100 Base-T
Connector: RJ45 with LEDs

Name: AUTOSTART
Function: Auto-ON
Connector: 3-pin female, screw-type
24Vdc \pm 25%, 100mA

Name: ETH2
Type: Ethernet 10/100 Base-T
Connector: RJ45 with LEDs

Name: MOUSE
Connector: standard PS2 miniDIN 6 pin (violet)

DIMENSIONS AND CUT OUT

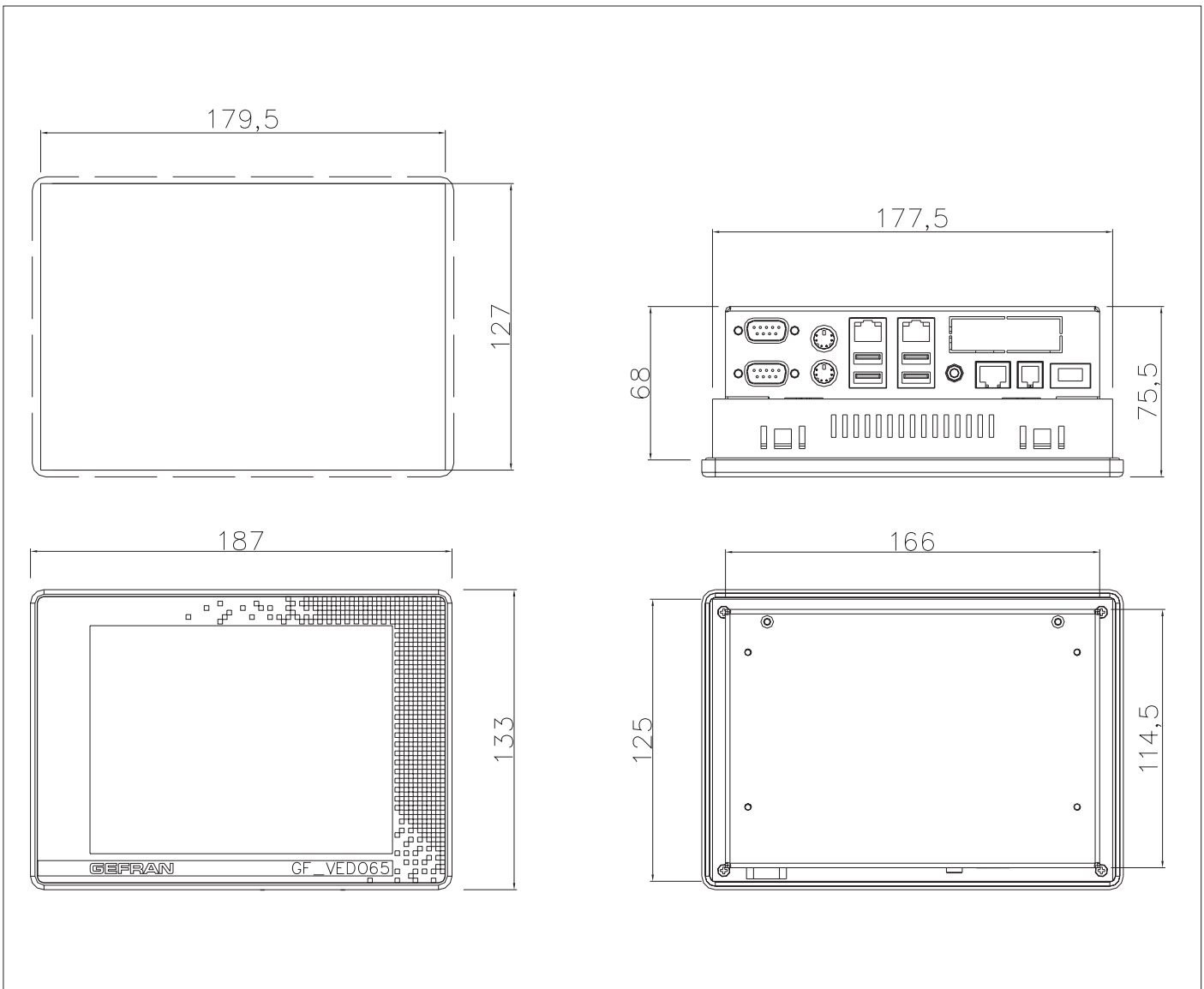

CONNECTIONS

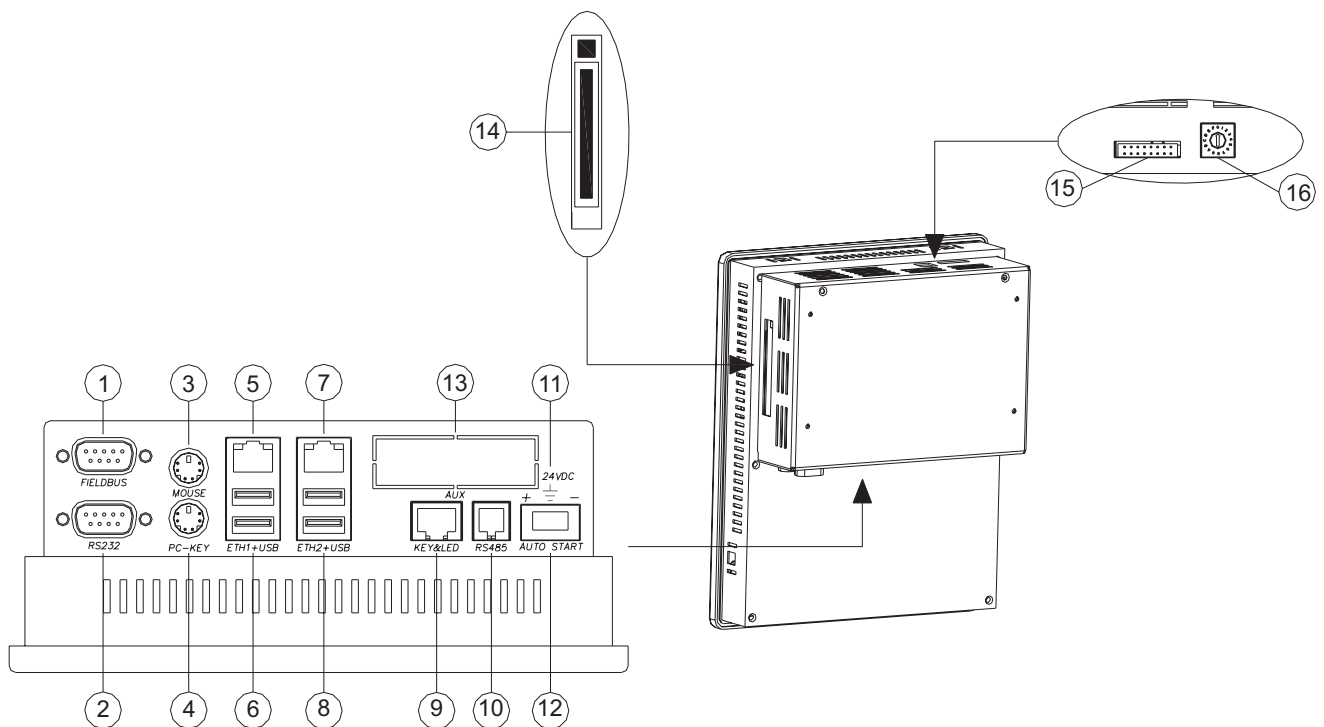

No	Name	Description
1	FIELD BUS	[Optional] -CAN layer 2
2	RS232	Serial RS-232
3	MOUSE	PS/2 Mouse (green)
4	PC-KEY	PS/2 keyboard (violet)
5	ETH1	Ethernet 10/100 Base-T
6	USB	USB 2.0 Host (500mA)
7	ETH2	Ethernet 10/100 Base-T
8	USB	USB 2.0 Host (500mA)
9	KEY & LED	Fieldbuses keyboard
10	RS485	RS-485 optically-isolated serial
11	AUTO-START	Auto-on
12	24VDC	Power supply
13	AUX	Reserved for future uses
14	CF	Compact Flash
15	BATTERY	Battery jumper
16	ROTARY	Rotary configuration selector

CONNECTION EXAMPLES

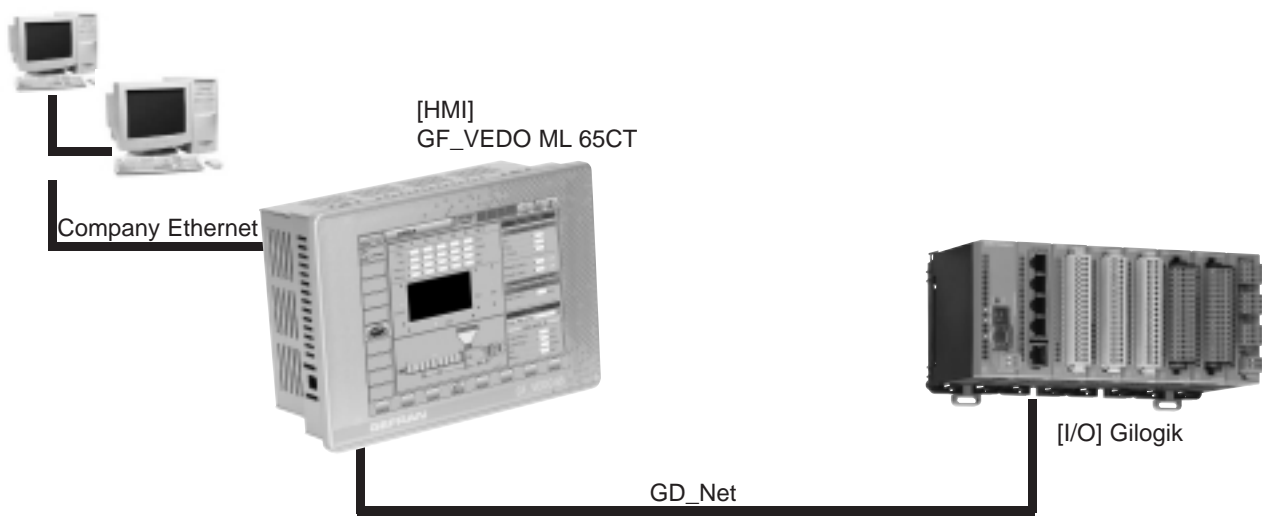
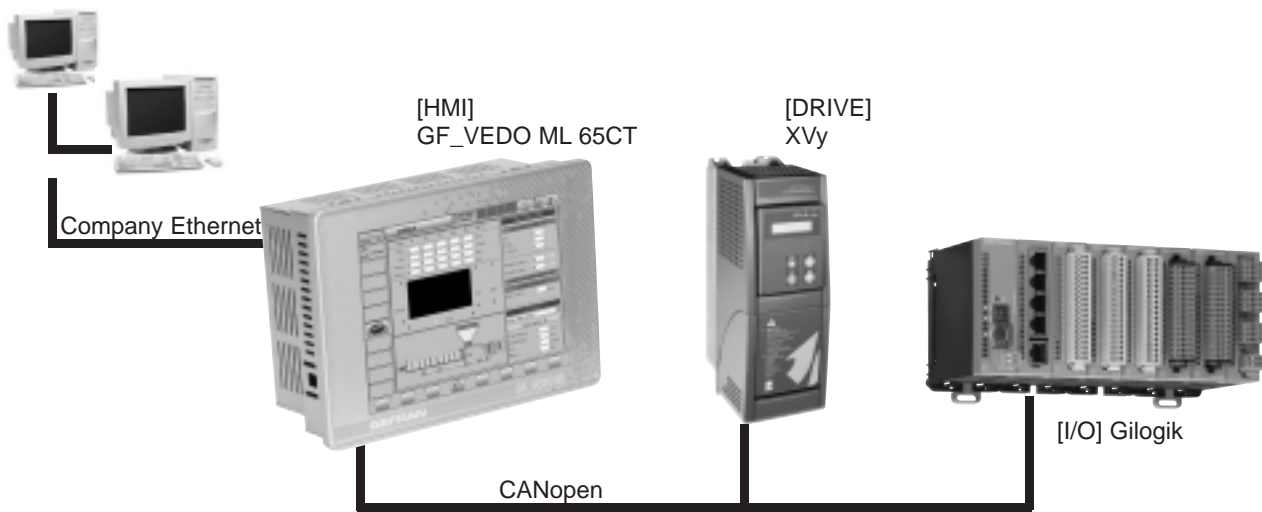
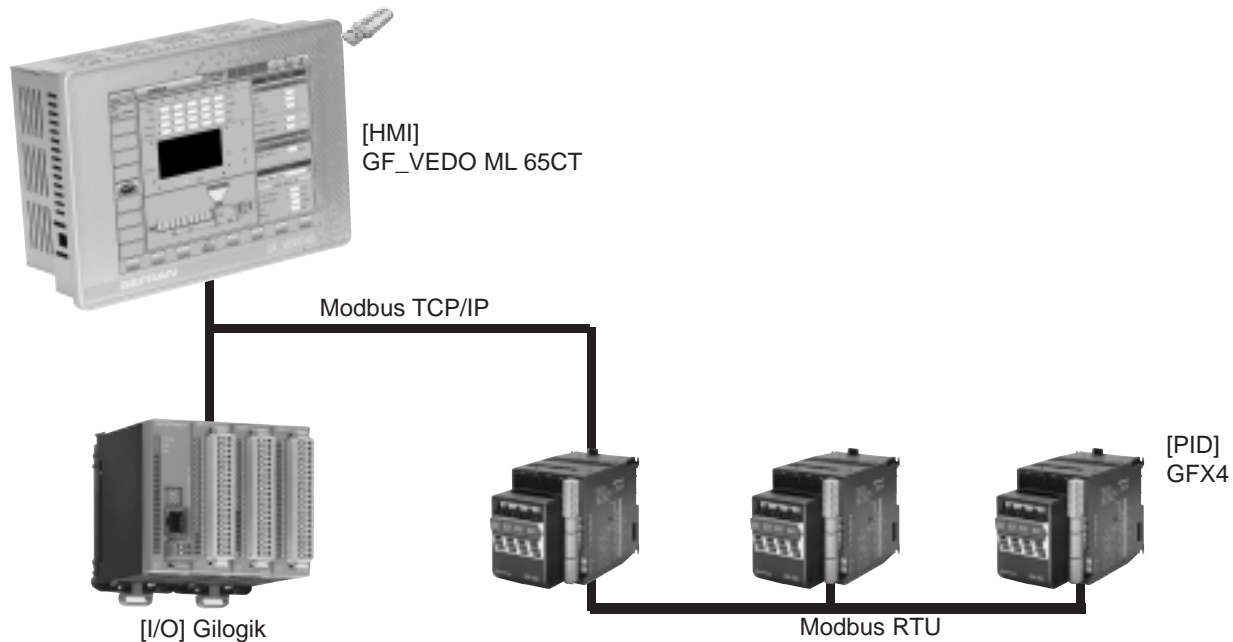

ORDER CODE

GF_VEDO ML 65CT 00 00 00 00

MODEL	
GF_VEDO ML 65CT	65CT
OPERATING SYSTEMS	
VxWorks CF: 1GB RAM: 128MB	VW0
VxWorks CF: 1GB RAM: 256MB	VW1
WinXP Embedded CF: 1GB RAM: 256MB	XE0
WinXP Embedded CF: 2GB RAM: 512MB	XE1
EXPANSION 1	
None	00
CANopen + RS232+ Autostart	C1
EXPANSION 2	
None	00
RS232 + Autostart	S1 (*)
LEXAN	
Gefran	G
Neutro	N

(*) only in absence of the expansion1 (C1)

Please, contact GEFRAN sales people for the codes availability.

GEFRAN spa reserves the right to make any kind of design or functional modification at any moment without prior notice

ACCESSORIES

Keyboards	Fieldbuses keyboard to manage movements.....	TF32-65
	Keyboard to integrate electromechanical buttons.....	TE5-65
Supply	Stabilized supply 100....240Vac/24Vdc, 5A.....	GF_PS5
Software	Preloaded software package for complete management of injection presses.....	GF_PACK INJECTION
	Preloaded software package for complete management of extrusion lines.....	GF_PACK EXTRUSION
	Integrated programming environment.....	Gefran Automation Builder
	Software platform for SCADA applications.....	VedoWin



In conformity to ECC 2004/108/CE (EMC) and 2006/95/CE (LVD) with reference to: **EN 61131-2** (product) **EN 61010-1** (safety).



GEFRAN spa
 via Sebina, 74
 25050 Provaglio d'Iseo (BS)
 Tel. +39 030 9888.1 - fax +39 030 9839063
 Internet: <http://www.gefran.com>