



Main applications

- Qwerty panel-type keyboard
- Expansion for monitor and PC touch screen

Main features

- Full 95 keys
- Reduced depth
- IP65 frontal panel protection
- Application in harsh environments
- Optional Touch Pad

FEATURES

DIGITAST is a PS/2-compatible industrial panel-type keyboard with 95 keys.

It is particularly indicated for expansion of industrial PCs with Touch Screen to simplify data insertion.

Its careful construction and mechanical design make it easy to install and give correct access to connections. Simple maintenance guarantees long life and reliability

TECHNICAL DATA

KEYBOARD

- PS2-compatible
- 95 keys
- 1.5 m. cable with Minidin PS/2 terminal
- Optional Touch Pad
- 1.5 m. cable with Minidin PS/2 terminal

POWER SUPPLY

- not required

AMBIENT OPERATING CONDITIONS

- IP 65 front panel protection
- Work temperature 0°C..+50°C
- Storage temperature
- 20°C..+70°C
- Humidity: 90% max., non-condensing

DIMENSIONS AND WEIGHTS

- 395x123x32 mm
- 1Kg max

KEYBOARD

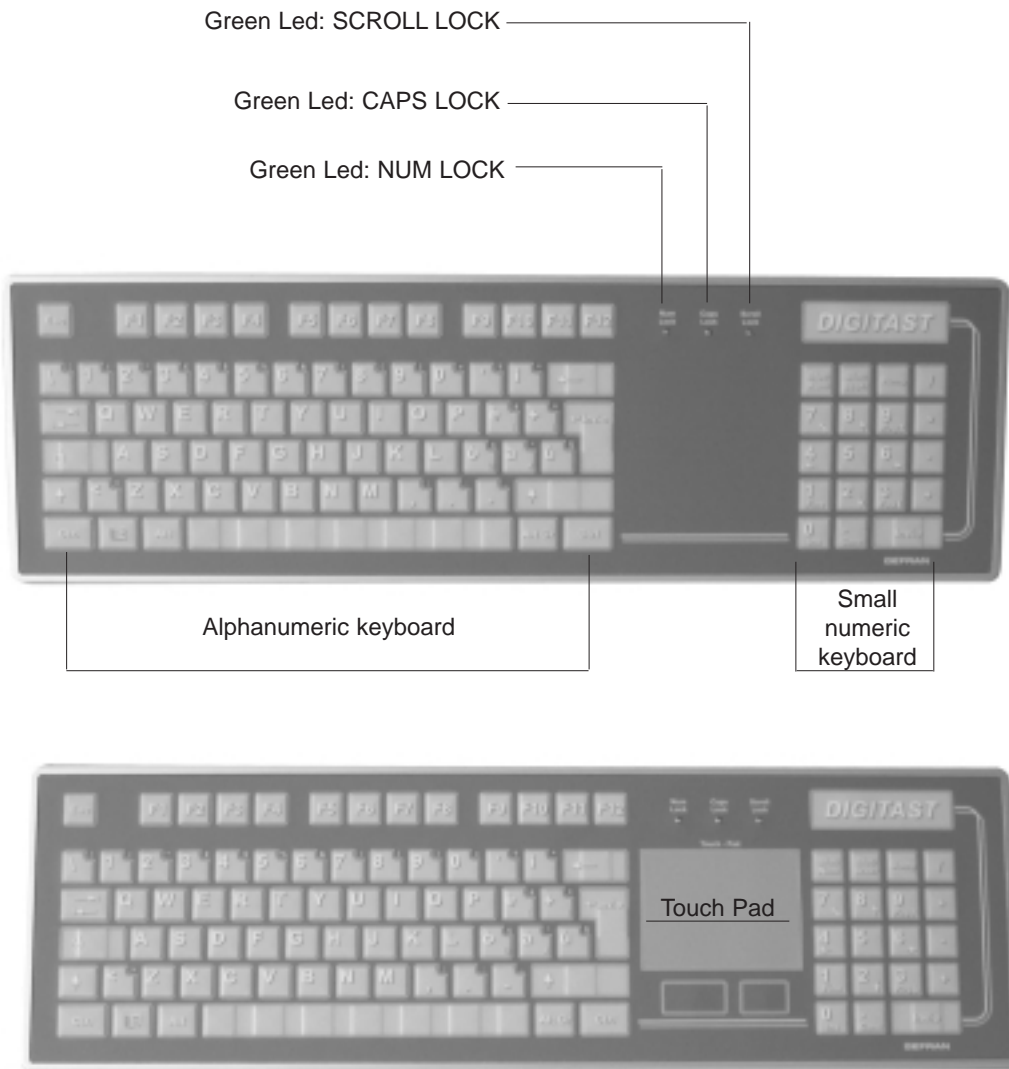

EXTERNAL USER CONNECTIONS

The keyboard comes with a 1.5 meter connection cable with minidin PS2 plug.

The Touch Pad version has a second 1.5 meter connection cable with minidin PS2 plug. The touch pad is seen as a PS2 mouse

See the technical manual for signal details.

Installation warnings

Do not install the product inside devices or boxes without adequate air circulation or heat exchange sufficient to keep the temperature below 50°C

Install the product in a position that will avoid accidental impact.

MECHANICAL CHARACTERISTICS AND OVERALL DIMENSIONS

DIGITAST basic version and with touch pad option

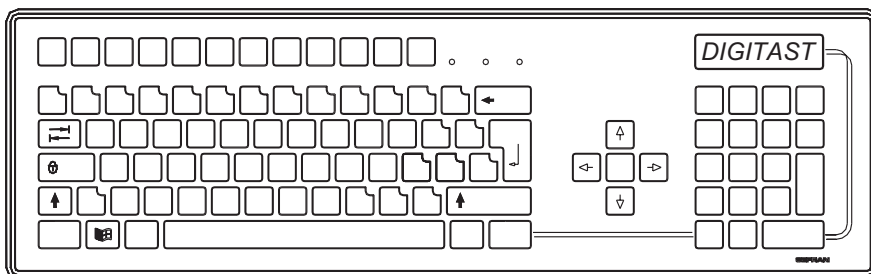
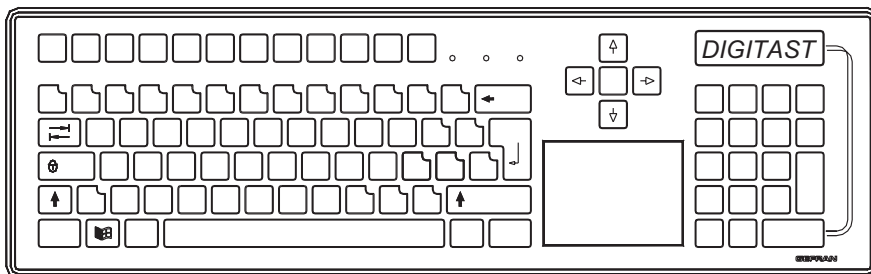
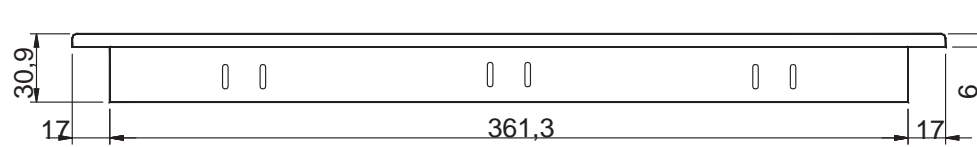
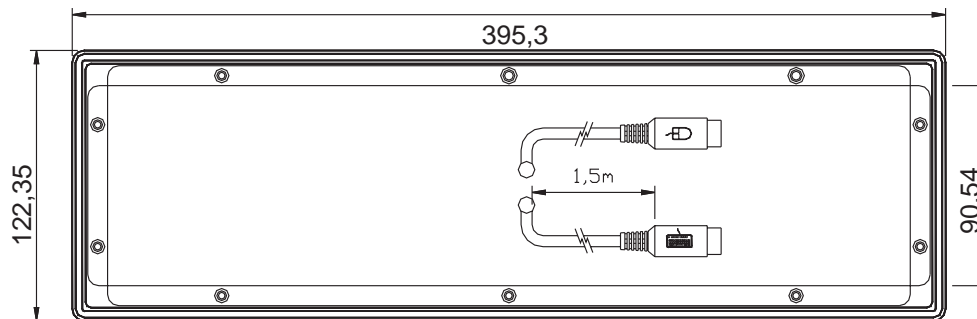
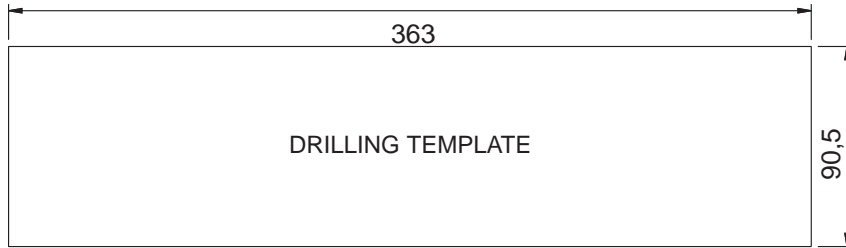

ORDER CODE

DGT



MOUSE	
None *	0
Touch Pad	1

* Standard model

Kindly contact GEFRAN for information on available codes.

GEFRAN spa reserves the right to make aesthetic or functional changes at any time and without notice



The instrument conforms to European Union Directives 89/336/CEE and 73/23/CEE with reference to generic standards:
CEI-EN 61000-6-2 (immunity in industrial environment) - EN 50081-1 (emissions in residential environments) - EN 61010-1 (safety)

GEFRAN

GEFRAN spa via Sebina, 74 - 25050 Provaglio d'Iseo (BS)
Tel. 03098881 - fax 0309839063 - Internet: <http://www.gefran.com>

DIGITAST - 07/05