



## Main applications

- Control of machines and systems
- Human-machine interface (HMI)
- Data display

## Main features

- 10.4", 12.1", 15" TFT Display
- High performance
- Modular configuration
- Connectivity
- Easy access and maintenance
- Reduced depth
- No internal wires

## FEATURES

DIGISTAR II Control version is an industrial PC with configuration and resource management and display functions.

This version combines the typical functions of PC architecture with a number of functions specifically designed for control applications, such as the use of the VxWorks operating system in GAB programming environment, all in a compact frame.

DIGISTAR II Control can be used in numerous industrial applications, from machine control units to data centralization system, from traditional human-machine interface (HMI), to system supervisor.

DIGISTAR II has a TFT display (10.4", 12.1", 15") and can be equipped with a resistive touch screen.

This version uses Intel Mobile class processors; such as the Celeron™ 600 MHz, Celeron 1500 MHz or Pentium 1800 MHz, which efficiently manages heat dissipation in order to limit use of the PC cooling fan.

DIGISTAR II Control can be fitted with a

DOM-type solid state mass storage for better configuration, depending on the application.

Thanks to the complete series of available ports (Ethernet, USB, serial, parallel, PS/2 etc.), DIGISTAR II Control can link to various peripherals commonly utilized in the industrial field.

Maximum connectivity is achieved by adding optional custom interfaces.

Available interfaces include: CAN bus, RS422/485 serial expansions and additional Ethernet channels.

A number of functions, Management of control keyboard, LED, and switch-on logic output with programmable timer, these are typical of this version for the control of machines or industrial lines. Careful construction and mechanical design make it easy to install and give correct access to expansions. Simple maintenance guarantees long life and reliability.

## TECHNICAL DATA

### PROCESSORS

- Intel Pentium Celeron™ 600 MHz (2Mb Cache L2)
- Intel Celeron Mobile™ 1500 MHz (2Mb Cache L2)
- Intel Pentium Mobile™ 1800 MHz (2Mb Cache L2)

### CHIPSET

- Intel™ 852GM, 400 MHz FSB

### VIDEO CONTROLLER

- Intel™ Extreme Graphics 2 Controller (up to 64MB DRAM Video)

### DISPLAY

- 10.4 color TFT 800x600 pixel 262K angle of view 120° / 100° contrast 500:1 Luminosity 230 cd/m<sup>2</sup>
- 12.1" color TFT 800x600 pixel 262Kcol. angle of view 140/110 H/V, contrast 500:1, Luminosity 600 cd/m<sup>2</sup>
- 15" color TFT 1024x768 pixel 262K col. angle of view 130°/120° H/V contrast 500:1, Luminosity 350 cd/m<sup>2</sup>

### DYNAMIC RAM

- DDR da 256MB, 512MB, 1GB

### STATIC RAM

- 256Kb with lithium backup battery

## MASS STORAGE

### SSD

- DOM 1Gb, 2Gb, 4Gb

### Magnetic

- optional HDD 2.5" IDE
- optional FDD  
(to connect to specific port)

## I/O PORTS

- 1 RS 232 serial port  
+ 1 RS232/RS422/RS485
- 2 USB 2.0 ports
- 1 Ethernet port RJ45 10/100Mbps
- 1 VGA port for external monitor
- PS/2 port for keyboard and mouse
- Centronics parallel port
- Synchronous serial port for matrix control max 128 keys and 64 LEDs
- 24VDC logic output open collector max. 100mA optically isolated for autostart with programmable timer; can be activated even with the system off.
- Connector for external battery

## EXPANSIONS

- 1 Slot PC104 slot 16 bit max. 3 boards
- 4 special slots for optional interfaces

## OPTIONAL INTERFACES

- **GT-SER2 module:** 2 serial ports COM3, COM4, 2xRS232/RS422/RS485 optically isolated

**COM4 is not available if a touch screen is installed.**

- **GT-CAN1 module:**  
1 channel CAN L2 optoisolated; CAN controller Intel 82527
- **GT-CAN2 module:**  
2 channels CAN L2 optoisolated; CAN controller Intel 82527
- **GT-ETH1 module:**  
1 Ethernet channel 10/100 Mbps Ethernet controller Intel 82551ER
- **GT-ETH2 module:**  
2 Ethernet channels Ethernet controller Intel 82551ER (see specific documents)

## KEYBOARDS AND CURSORS

- 10 front-panel function keys, ENTER key and TAB (12.1" and 15")
- Optional 5-wire resistive touch
- Optional DIGITAST keyboard with optional mouse pad
- Matrix control: DIGITAST m61 (optional)

## DIAGNOSTICS

- Front-panel LEDs with function indication
- Alarm and operating state LEDs

## POWER SUPPLY

- 18..30Vdc 2.5 A max. with polarity protection and galvanic insulation
- Short circuit protection with resettable PTC.
- ON/OFF switch

## OPERATING SYSTEMS

- VxWorks™

## AMBIENT OPERATING CONDITIONS

- IP 65 front panel protection
- Operating temperature 0°C..+50°C
- Storage temperature -10°C..+70°C
- Humidity: 90% max., non-condensing

## DIMENSIONS AND WEIGHTS

- With 10,4" display :  
309x239x117 mm - 4 Kg max
- With 12,1" display :  
335x295x117 mm - 5 Kg max
- With 15" display :  
395x340x117 mm - 7 Kg max

## FRONT PANEL

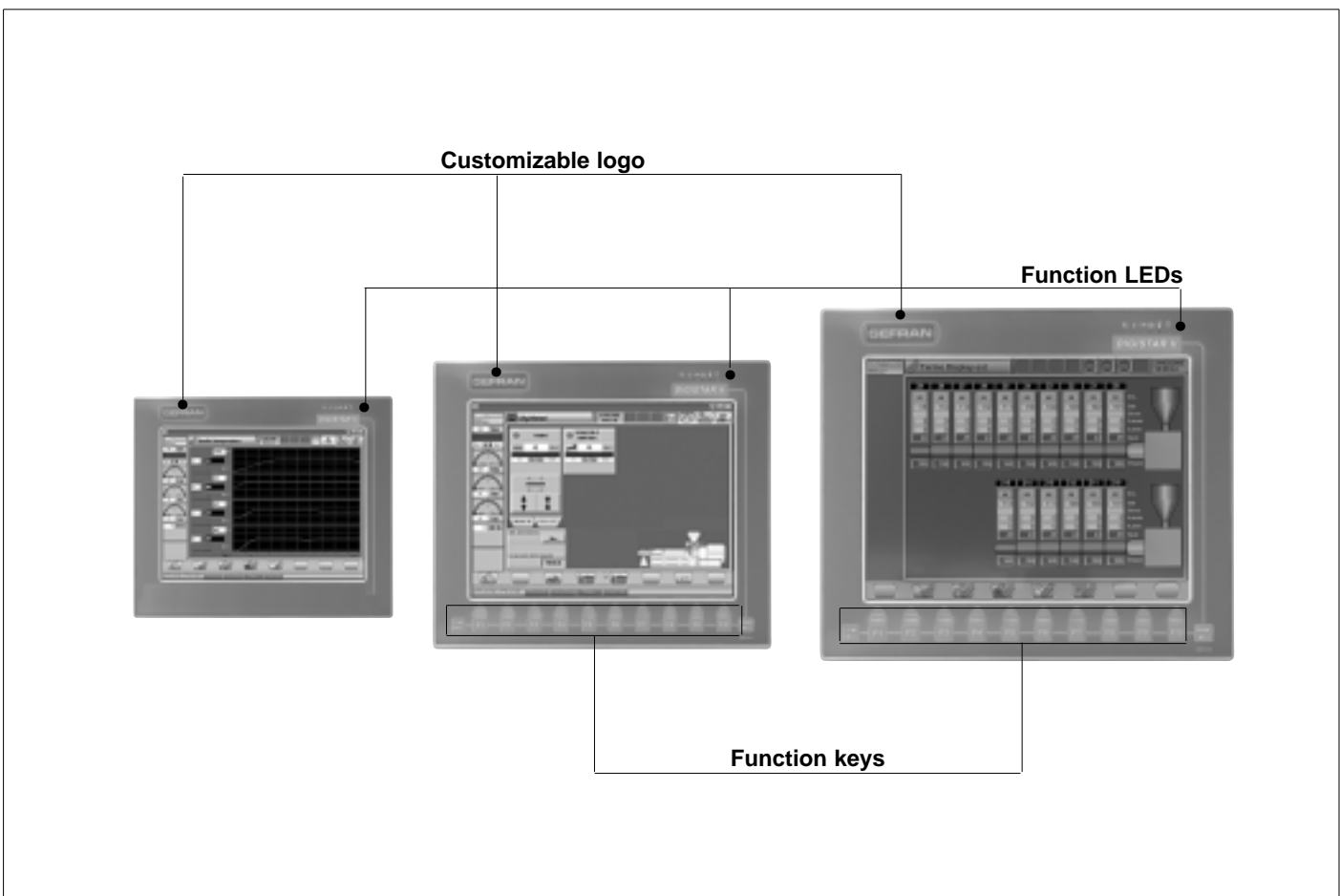

## CONNECTIONS and OPTIONS

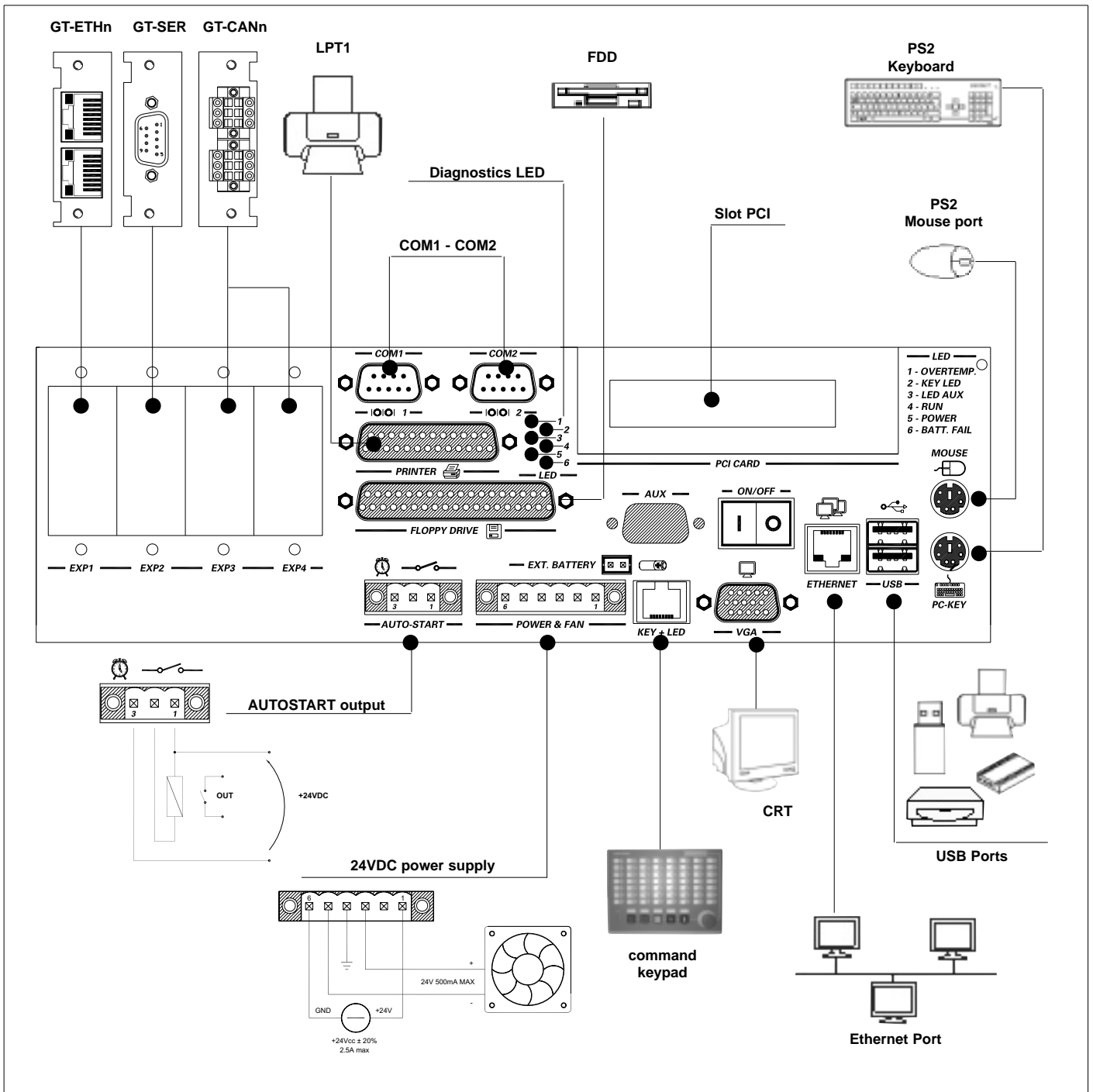

## INTERNAL VIEW AND CONFIGURATION OPTIONS

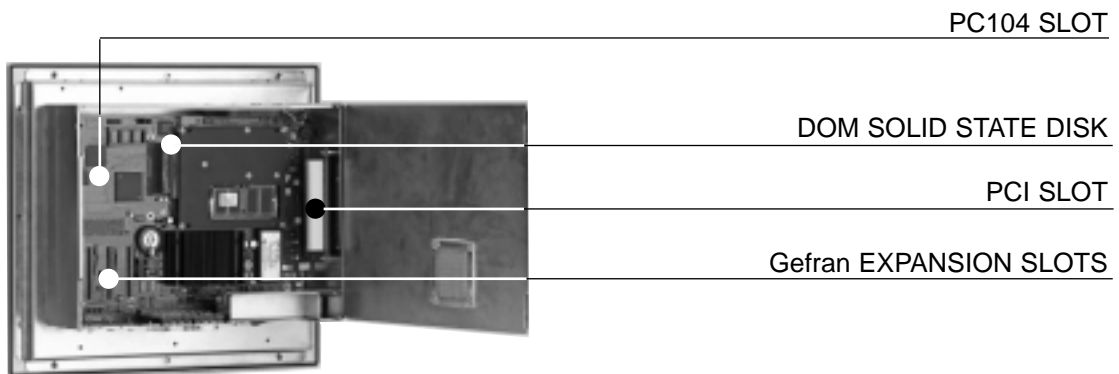

**MECHANICAL CHARACTERISTICS AND OVERALL DIMENSIONS**

**10.4" Version**

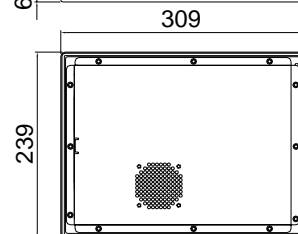
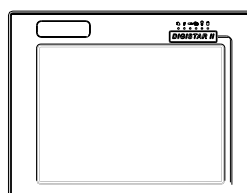
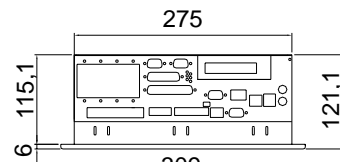
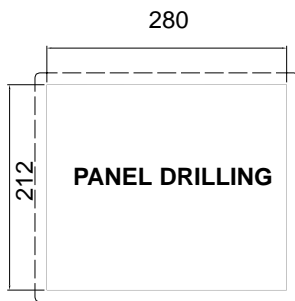
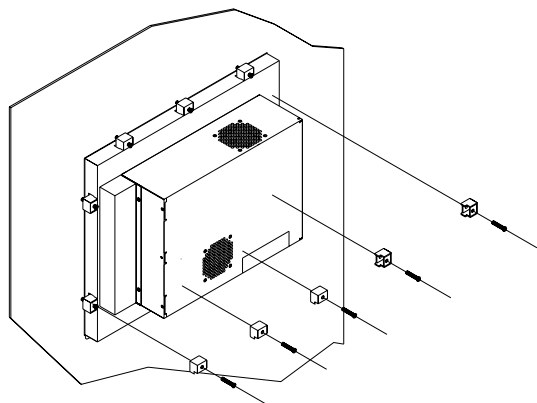

**12.1" Version**

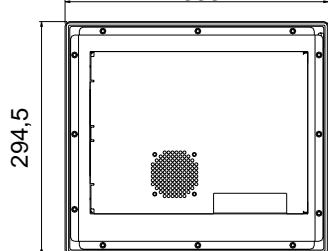
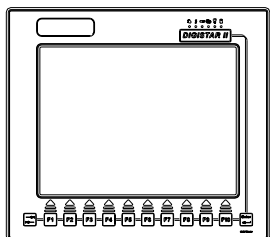
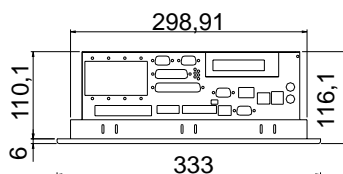
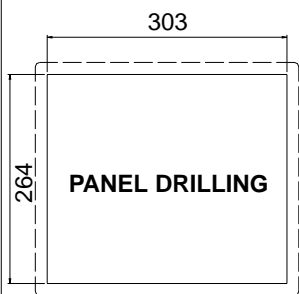

**15" Version**

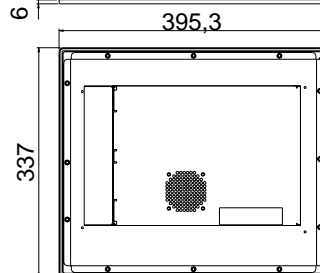
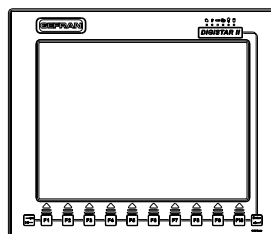
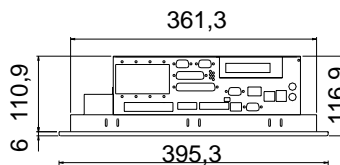
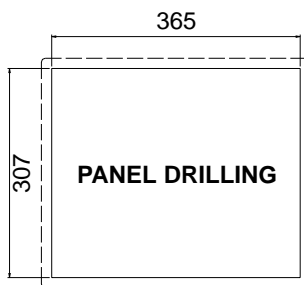

**Installation warnings**

DO NOT install the product in devices or boxes without adequate air circulation or heat exchange sufficient to maintain the temperature below 50°C.

When installing the product, be careful to position it so as to prevent accidental knocking.

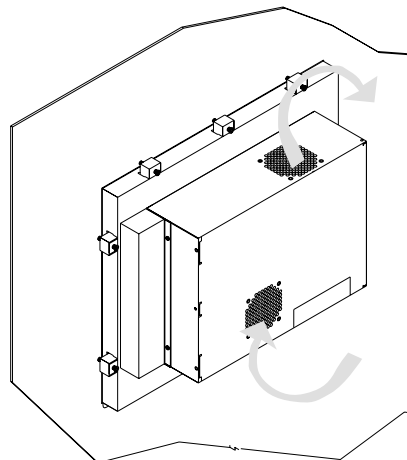

## ORDER CODE

	MOD	SO	μP	RAM	DOM	EXP1	EXP2	EXP3	EXP4
DGS II C	-	-	-	-	-	-	-	-	-

MODEL	
10.4" color TFT 800x600	10
10.4" color TFT 800x600 + touch screen	10T
12.1" color TFT 800x600	12
12.1" color TFT 800x600 + touch screen	12T
15" color TFT 1024x768	15
15" color TFT 800x600 + touch screen	15T

OPERATING SYSTEM	
Rom-dos	00
VxWorks™	VW

PROCESSOR	
Intel Pentium Celeron™ 600 MHz	PCE
Intel Celeron Mobile™ 1500 MHz	PCM
Intel Pentium Mobile™ 1800 MHz	PCT

DRAM	
DDR 128 MB	R128
DDR 256 MB	R256
DDR 512 MB	R512
DDR 1024 MB	R1G0

DOM & HD	
DOM 64 Mb	D064
DOM 128 Mb	D128
DOM 1 Gb	D1G0
DOM 2 Gb	D2G0
DOM 4 Gb	D4G0

CUSTOM SLOT 4 EXPANSION	
00	none
C1	GT-CAN1: 1 channel CAN
C2	GT-CAN2: 2 channels CAN

CUSTOM SLOT 4 EXPANSION	
00	none
C1	GT-CAN1: 1 channel CAN
C2	GT-CAN2: 2 channels CAN

CUSTOM SLOT 2 EXPANSION	
00	none
SR	GT-SER2: 2 serial channels (1)



CUSTOM SLOT 1 EXPANSION	
00	none
E1	GT-ETH1: 1 Ethernet channel
E2	GT-ETH2: 2 Ethernet channels

(1) Only 1 channel with touch screen

Kindly contact GEFTRAN for information on available codes.

GEFRAN spa reserves the right to make aesthetic or functional changes at any time and without notice

	Conformity UL508 File no. E198546
	In conformity to ECC 2004/108/CE (EMC) and 2006/95/CE (LVD) with reference to: <b>EN 61131-2</b> (product) <b>EN 61010-1</b> (safety).

# GEFRAN

GEFRAN spa via Sebina, 74 - 25050 Provaglio d'Iseo (BS)  
Tel. 03098881 - fax 0309839063 - Internet: <http://www.gefran.com>

DTS\_DIGISTAR II C\_0109\_ENG