

Catalogue 2007

AC Inverter • Flux Vector Control

ARTDrive - AVy



...life is performance.

English__Italiano__Français__Deutsch__Español





Certificate No. FM 38167

Gefran S.p.A. (Gerenzano plant), operates a Quality Management System which complies with the requirements of BS EN ISO 9001:2000



A UNI EN ISO9001:2000 certified quality company Customer satisfaction is GEFRAN-SIEI's primary aim: it is from this that mutual collaboration, maximum trust in the company and a consolidated long-standing partnership role stem. GEFRAN-SIEI ensures total support through its technical services (from design and start-up right up to onstream assistance), which are more highly specialized than those which large multi-sector companies are able to offer. GEFRAN-SIEI always meets the demands of high tech users with the certainty of total quality.

Una azienda di qualità certificata UNI EN ISO9001:2000 La soddisfazione del cliente è il primo degli obiettivi GEFRAN-SIEI: da qui nasce la reciproca collaborazione, la massima fiducia nell'azienda e il ruolo di partnership consolidata nel tempo. Attraverso i propri Servizi Tecnici, GEFRAN-SIEI garantisce un supporto globale, (dalla progettazione alla messa in funzione, fino all'assistenza in esercizio), molto più specializzato di quello che le grandi società multisettoriali sono in grado di offrire. Alla domanda di un'utenza evoluta, GEFRAN-SIEI risponde sempre con la certezza della qualità totale.

Une entreprise de qualité certifiée UNI EN ISO9001:2000 La satisfaction du client est le premier objectif de GEFRAN-SIEI: c'est à partir de là qu'est née la collaboration réciproque, la plus grande confiance dans l'entreprise et le rôle de partenaire renforcé dans le temps. Par ses propres Services Techniques, GEFRAN-SIEI, garantit un support global, (de la conception à la mise en service, jusqu'à l'assistance en exercice), beaucoup plus spécialisé que celui que les grandes sociétés multi-sectorielles sont à même d'offrir. A la demande d'une utilisation évoluée, GEFRAN-SIEI répond toujours avec la certitude de la qualité totale.

Ein Qualitätsbetrieb mit UNI EN ISO9001:2000-Zertifizierung Eine uneingeschränkte Kundenzufriedenheit ist das oberste Ziel von GEFRAN-SIEI: sie führt zu einer gemeinsamen Zusammenarbeit, absolutem Vertrauen in die Firma und einer im Laufe der Zeit gefestigten partnerschaftlichen Beziehung. Durch den technischen Service garantiert GEFRAN-SIEI umfassende Unterstützung (vom Entwurf über die Inbetriebnahme, bis hin zum Kundendienst), die kundennäher ist, als der angebotene Service von großen multisektorialen Gesellschaften. GEFRAN-SIEI bietet auch auf innovative Anfragen die Sicherheit einer umfassenden Qualität.

Una administración de calidad certificada por ISO 9001. La satisfacción del cliente es el primero de los objetivos de Gefran-Siei: de aquí nace la colaboración recíproca, la máxima confianza en la administración y el rol de asociación consolidada con el tiempo. A través de los propios Servicios Técnicos, GEFRAN-SIEI garantiza un soporte global del proyecto, desde la puesta en funcionamiento, hasta la asistencia en el ejercicio, más especializado de lo que las grandes sociedades multisectoriales pueden ofrecer. A la demanda de un servicio cualificado, GEFRAN-SIEI responde siempre con la certeza de la calidad total.



ARTDrive AC Vector Inverter

*Inverter vettoriali
Variateurs vectoriels
Vektor-Frequenzumrichter
Inverters vectoriales*



- Overview 3**
- Software 5**
- Ordering Codes 67**
 - Standard Version 67
 - Cabinet Versions 70
 - Open Frame Versions 70
 - Special Versions 71
 - Input Side External Fuses (F1) 74
 - External Fuses for a DC Connection 75
 - Input Chokes 77
 - Output Chokes 77
 - EMC Filter 77
 - Braking Resistors 77
 - External Braking Unit 77
 - Options 78
 - Field Bus Interface 86

Standard Versions

- General Features 9**
 - Introduction 8
 - Identification Code 8
- Inverter Selection 14**
- Typical Connection Scheme .. 21**
- Technical Specifications 22**
 - Dimensions and Weights 22
 - Mounting Method 22
 - Inverter Dissipation and Fan Flow 25

Cabinet & Open Frame Ver.

- General Features 27**
 - Introduction 26
 - Identification Code 26
- Inverter Selection 32**
- Typical Connection Scheme ... 35**
- Technical Specifications 37**
 - Dimensions and Weights 37
 - Inverter Dissipation and Fan Flow 39

Special Versions

- General Features 43**
 - Introduction 41
 - Identification Code 42
- Inverter Selection 48**
- Typical Connection Scheme .. 56**
- Technical Specifications 58**
 - Dimensions and Weights 58
 - Mounting Method 58
 - Inverter Dissipation and Fan Flow 65

- Generalità 3**
- Software 5**
- Codici di Ordinazione 67**
 - Versioni standard 67
 - Versioni in armadio 70
 - Versioni a giorno 70
 - Versioni speciali 71
 - Fusibili Esterni Lato Ingresso (F1) 74
 - Fusibili Esterni per la Connessione DC 75
 - Induttanze di Rete 77
 - Induttanze di Uscita 77
 - Filtri EMI 77
 - Resistenze di Frenatura 77
 - Unità di Frenatura Esterna 77
 - Opzioni 78
 - Interfaccia bus di campo 86

Versioni standard

- Caratteristiche Generali 10**
 - Introduzione 8
 - Codice di Identificazione 8
- Scelta dell'Inverter 14**
- Schema Tipico di Collegamento.21**
- Specifiche Tecniche 22**
 - Dimensioni e Pesì 22
 - Metodo di Montaggio 22
 - Dissipazione Inverter e Portata Ventilatori .. 25

Versioni in armadio e a giorno

- Caratteristiche Generali 28**
 - Introduzione 26
 - Codice di Identificazione 26
- Scelta dell'Inverter 32**
- Schema Tipico di Collegamento.35**
- Specifiche Tecniche 37**
 - Dimensioni e Pesì 37
 - Dissipazione Inverter e Portata Ventilatori .. 39

Versioni speciali

- Caratteristiche Generali 44**
 - Introduzione 41
 - Codice di Identificazione 42
- Scelta dell'Inverter 48**
- Schema Tipico di Collegamento.56**
- Specifiche Tecniche 58**
 - Dimensioni e Pesì 58
 - Metodo di Montaggio 58
 - Dissipazione Inverter e Portata Ventilatori .. 65

ARTDrive

Standard Versions

Cabinet & Open Frame Versions

Special Versions



Sommaire

Généralités	4
Logiciel	5
Codes pour la Commande	67
Versions Standards	67
Versions en Armoire	70
Versions à jour	70
Versions spéciales	71
Fusibles Réseau Externes (F1)	74
Fusibles Externes pour Raccordement sur Bus DC ..	75
Inductances de Réseau	77
Inductances de Sortie	77
Filtres CEM	77
Résistances de Freinage	77
Unité de Freinage Extérieure	77
Options	78
Interface bus de terrain	86



Inhaltsverzeichnis

Allgemeines	4
Software	5
Bestellnummern	67
Standardserien	67
Schrankschaltungen	70
Freiluftausführung	70
Sonderausführungen	71
Externe Sicherungen Eingangsseite (F1)	74
Externe Sicherungen für DC-Anschluss	75
Netzrosseln	77
Ausgangsdrosseln	77
EMV-Filter	77
Bremswiderstände	77
Externe Bremsseinheiten	77
Optionen	78
Feldbus-Schnittstelle	86



Indice

General	4
Software	5
Códigos de Mandos	67
Standard Versions	67
Versiones en armario	70
Versiones por día	70
Versiones especiales	71
Fusibles Externos del Lado de Alimentación de Red 74	74
Fusibles Externos para Conexión en CC	75
Inductancia de Red	77
Inductancia de Salida	77
Filtros EMI	77
Resistencias de Frenado	77
Unidad de Frenado Externa	77
Opciones	78
Interfaces de Bus de campo	86

Versions Standards

Caractéristiques générales ..	11
Introduction	8
Code d'identification	8
Sélection du variateur	14
Schéma typique de raccordement	21
Spécifications techniques	22
Dimensions et poids	22
Mode de montage	22
Dissipation du variateur et débit des ventilateurs	25

Standardserien

Allgemeine Merkmale	12
Einleitung	8
Identifikationscode	8
Wahl des Frequenzumrichters	15
Typischer Anschlussplan	21
Technische Spezifikationen ..	22
Abmessungen und Gewichte	22
Montageart	22
Frequenzumrichter-Verlustleistung und Lüfterleistung	25

Standard Versions

Características Generales	13
Introducción	8
Siglas Identificación Producto	8
Selección del Convertidor	15
Diagrama Típico de Conexión .	21
Especificaciones Técnicas	22
Dimensiones y Pesos	22
Metodos de Montaje	22
Disipación del Convertidor de Frecuencia y Ventilación forzada	25

Versions en armoire et à jour

Caractéristiques générales ...	29
Introduction	26
Code d'identification	26
Sélection du variateur	32
Schéma typique de raccordement	35
Spécifications techniques	37
Dimensions et poids	37
Dissipation du variateur et débit des ventilateurs	39

Schrankschaltungen und Freiluftausführung

Allgemeine Merkmale	30
Einleitung	26
Identifikationscode	26
Wahl des Frequenzumrichters .	32
Typischer Anschlussplan	35
Technische Spezifikationen ...	37
Abmessungen und Gewichte	37
Frequenzumrichter-Verlustleistung und Lüfterleistung	39

Versiones en armario y por día

Características Generales	31
Introducción	26
Siglas Identificación Producto	26
Selección del Convertidor	32
Diagrama Típico de Conexión ..	35
Especificaciones Técnicas	37
Dimensiones y Pesos	37
Disipación del Convertidor de Frecuencia y Ventilación forzada	39

Versions spéciales

Caractéristiques générales ..	45
Introduction	41
Code d'identification	42
Sélection du variateur	48
Schéma typique de raccordement	56
Spécifications techniques	58
Dimensions et poids	58
Mode de montage	58
Dissipation du variateur et débit des Ventilateurs	65

Sonderausführungen

Allgemeine Merkmale	46
Einleitung	41
Identifikationscode	42
Wahl des Frequenzumrichters	49
Typischer Anschlussplan	56
Technische Spezifikationen ..	58
Abmessungen und Gewichte	58
Montageart	58
Frequenzumrichter-Verlustleistung und Lüfterleistung	65

Versiones especiales

Características Generales	47
Introducción	41
Siglas Identificación Producto	42
Selección del Convertidor	49
Diagrama Típico de Conexión .	56
Especificaciones Técnicas	58
Dimensiones y Pesos	58
Metodos de Montaje	58
Disipación del Convertidor de Frecuencia y Ventilación forzada	65

Generalità
Généralités
Allgemeines
General



ARTDrive

 The **ARTDrive - AVy** series represents an innovative field-oriented vector inverter concept, which is extremely adaptable to a system's technological requirements.

With its integrated advanced functions, high level of accuracy and exceptional performance, this product is ideal for use in complex systems involved in controlling automated machines, production lines, hoisting equipment and in any other application environment where control solutions for complex architectures are vital.

Compatible with every type of power supply, the AVy range also offers complete versatility, adapting to any mechanical and cooling installation requirements.

Standard versions

- **AVy & AVy...-4A** Power supply 3ph 230Vac...480Vac, 50/60Hz, motor ratings from 0.75kW (0.75Hp) to 200kW (250Hp).
Power supply 3ph 400Vac...480Vac, 50/60Hz, motor ratings from 250kW (300Hp) to 315kW (420Hp).
- **AVy...-5** Power supply 3ph 575Vac, 50/60Hz. Motor ratings from 2Hp to 200Hp.

Cabinet versions

- **AVy Cabinet** Power supply 3ph 400Vac...480Vac, 50/60Hz. Motor ratings from 250kW (300Hp) to 630kW (700Hp).

Special versions

DC bus power supply versions

- **AVy...DC** Rectified voltage supply up to 480Vac, 50/60Hz. Motor ratings from 22kW (25Hp) to 630kW (700Hp).

Versions with external heat sink assembly

- **AVy...EH** Power supply 3ph 230Vac...480Vac, 50/60Hz. Motor ratings from 22kW (25Hp) to 55kW (60Hp).

Liquid cooling versions

- **AVy...WH** Power supply 3ph 230Vac...480Vac, 50/60Hz. Motor ratings from 11kW (15Hp) to 132kW (150Hp).

 La serie **ARTDrive - AVy** è un'innovativa concezione di Inverter Vettoriale ad orientamento di campo, altamente flessibile ad ogni esigenza tecnologica di sistema.

L'integrazione di funzioni evolute, l'elevata precisione e l'altissima dinamica, rendono il prodotto eccellente all'impiego in sistemi complessi per il controllo di macchine automatiche, linee di produzione, impianti di sollevamento ed in qualsiasi contesto applicativo dove siano indispensabili soluzioni di controllo per architetture complesse.

Disponibile per alimentazioni universali la gamma **AVy** offre inoltre una completa versatilità a qualsiasi soluzione d'installazione meccanica e di raffreddamento.

Versioni Standard

- **AVy & AVy...-4A** Alimentazione 3ph 230Vac...480Vac, 50/60Hz, potenze motori da 0,75kW (0,75Hp) a 200kW (250Hp).
Alimentazione 3ph 400Vac...480Vac, 50/60Hz, potenze motori da 250kW (300Hp) a 315kW (420Hp).
- **AVy...-5** Alimentazione 3ph 575Vac, 50/60Hz. Potenze motori da 2Hp a 200Hp.

Versioni in Armadio

- **AVy Cabinet** Alimentazione 3ph 400Vac...480Vac, 50/60Hz. Potenze motori da 250kW (300Hp) a 630kW (700Hp).

Versioni speciali

Versioni per alimentazione da DC bus

- **AVy...DC** Alimentazione da tensioni raddrizzate fino a 480Vac, 50/60Hz. Potenze motori da 22kW (25Hp) a 630kW (700Hp).

Versioni con montaggio dissipatore esterno

- **AVy...EH** Alimentazione 3ph 230Vac...480Vac, 50/60Hz. Potenze motori da 22kW (25Hp) a 55kW (60Hp).

Versioni per raffreddamento a liquido

- **AVy...WH** Alimentazione 3ph 230Vac...480Vac, 50/60Hz. Potenze motori da 11kW (15Hp) a 132kW (150Hp).



 La série **ARTDrive - AVy** est une conception novatrice de Variateurs Vectoriels à orientation de champ, s'adaptant particulièrement à chaque exigence de technologie de système.

L'intégration de fonctions de pointe, la haute précision et l'excellente dynamique, permettent au produit d'être idéal pour l'utilisation dans des systèmes complexes pour le contrôle de machines automatiques, de lignes de production, d'installations de lavage et dans n'importe quel contexte d'application ou il faut impérativement des solutions de contrôle pour des architectures complexes.

Disponible pour des alimentations universelles la gamme AVy offre également une polyvalence complète pour toutes les solutions d'installation mécanique et de refroidissement.

Versions Standards

- **AVy & AVy...-4A** Alimentation 3ph 230Vca...480Vca, 50/60Hz, puissances des moteurs de 0,75kW (0,75Hp) à 200kW (250Hp).
Alimentation 3ph 400Vca...480Vca, 50/60Hz, puissances des moteurs de 250kW (300Hp) à 315kW (420Hp).
- **AVy...-5** Alimentation 3ph 575Vca, 50/60Hz. Puissances des moteurs de 2 Hp à 200 Hp.

Versions en Armoire

- **AVy Cabine** Alimentation 3ph 400Vca...480Vca, 50/60Hz. Puissances des moteurs de 250 kW (300 Hp) à 630 kW (700 Hp).

Versions spéciales

Versions pour alimentation par DC bus

- **AVy...DC** Alimentation par des tensions redressées jusqu'à 480Vca, 50/60Hz. Puissances des moteurs de 22 kW (25 Hp) à 630 kW (700 Hp)

Versions avec montage d'un dissipateur extérieur

- **AVy...EH** Alimentation 3ph 230Vca...480Vca, 50/60Hz. Puissances moteurs de 22 kW (25 Hp) à 55 kW (60 Hp).

Version pour refroidissement à liquide

- **AVy...WH** Alimentation 3ph 230Vca...480Vca, 50/60Hz. Puissances moteurs de 11 kW (15 Hp) à 132 kW (150 Hp)

 Die Serie **ARTDrive – AVy** stellt eine innovative Interpretation des Vektor-Frequenzumrichters mit Feldorientierung dar und bietet hohe Flexibilität für alle technologischen Systemansprüche.

Hoch entwickelte Funktionen, besondere Präzision und starke Dynamik machen das Produkt perfekt für den Einsatz in komplexen Steuersystemen für automatische Maschinen, Produktionslinien, Hebeanlagen und alle anderen Anwendungsgebiete, in denen Lösungen für die Regelung komplexer Architekturen unerlässlich sind.

Die AVy-Produktpalette ist für einen weiten Spannungsbereich erhältlich und außerdem flexibel einsetzbar für verschiedene mechanische Einbauweisen und Kühlsysteme.

Standardserien

- **AVy und AVy...-4A** Versorgung 3Ph 230 VAC...480 VAC, 50/60 Hz, Motorleistungen von 0,75 kW (0,75 Hp) bis 200 kW (250 Hp).
Versorgung 3Ph 400 VAC...480 VAC, 50/60 Hz, Motorleistungen von 250 kW (300 Hp) bis 315 kW (420 Hp).
- **AVy...-5** Versorgung 3Ph 575 VAC, 50/60 Hz. Motorleistungen von 2 Hp bis 200 Hp.

Schranksausführungen

- **AVy Schaltschrank** Versorgung 3Ph 400 VAC...480 VAC, 50/60 Hz. Motorleistungen von 250 kW (300 Hp) bis 630 kW (700 Hp).

Sonderausführungen

Ausführungen für DC Bus-Versorgung

- **AVy...DC** Versorgung durch gleichgerichtete Spannungen bis 480 VAC, 50/60 Hz. Motorleistungen von 22 kW (25 Hp) bis 630 kW (700 Hp).

Ausführungen mit extern montiertem Kühlkörper

- **AVy...EH** Versorgung 3Ph 230 VAC...480 VAC, 50/60 Hz. Motorleistungen von 22 kW (25 Hp) bis 55 kW (60 Hp).

Ausführungen mit Flüssigkühlung

- **AVy...WH** Versorgung 3Ph 230 VAC...480 VAC, 50/60 Hz. Motorleistungen von 11 kW (15 Hp) bis 132 kW (150 Hp).

 La serie **ARTDrive - AVy** representa una concepción innovadora del Inverter Vectorial de orientación de campo, altamente flexible frente a cualquier exigencia tecnológica de sistema.

La integración de las funciones evolucionadas, la elevada precisión y la altísima dinámica, consiguen que el producto sea perfecto para su uso en sistemas complejos para el control de maquinaria automática, líneas de producción, instalación de elevadores y en cualquier tipo de contexto de aplicación en que sean necesarias soluciones de control para arquitecturas complejas.

Disponible para alimentación universal la gama AVy ofrece además una gran versatilidad para cualquier solución de instalación mecánica y de refrigeración.

Versiones Estándar

- **AVy & AVy...-4A** Alimentación trifásica 3ph 230Vac...480Vac, 50/60Hz, potencias de motores de 0,75kW (0,75CV) a 200kW (250CV).
Alimentación trifásica 3ph 400Vac...480Vac, 50/60Hz, potencias de motores de 250kW (300CV) a 315kW (420CV).
- **AVy...-5** Alimentación trifásica 575Vac, 50/60Hz. Potencias de motores desde 2CV hasta 200CV

Versiones en Armario

- **AVy Cabinet** Alimentación trifásica 400Vac ... 480 Vac, 50/60Hz. Potencias de motores desde 250W (300CV) hasta 630kW (700CV)

Versiones especiales

Versiones para alimentación del DC bus

- **AVy...DC** Alimentación de tensiones rectificadas hasta 480 Vca, 50/60Hz. Potencias de motores desde 22kW (25CV) hasta 630kW (700CV)

Versiones con montaje de dissipador externo

- **AVy...EH** Alimentación trifásica 230Vac ... 480 Vac, 50/60Hz. Potencias de motores desde 22kW (25CV) hasta 55kW (60CV)

Versiones con refrigeración líquida

- **AVy...WH** Alimentación trifásica 230Vac ... 480 Vac, 50/60Hz. Potencias de motores desde 11kW (15CV) hasta 132kW (150CV)

Programming Menu

 The AVy inverter's programming structure allows you to configure the system and set the motor parameters simply and logically.

The inverter's parameters are divided up according to function type, guaranteeing an intuitive way of interpreting any operations which involve changing, managing and accessing the functions.

The main parameter groups are classified as follows:

- setting basic parameters
- parameter monitor and operating variables
- motor / inverter configuration and setting system thresholds
- input / output configuration
- control function and parameter configuration
- dedicated function configuration

Menu di Programmazione

 La struttura di programmazione dell'inverter AVy, consente di eseguire la configurazione del sistema e la parametrizzazione del motore in modo semplice e razionale.

I parametri dell'inverter suddivisi per tipologia di funzione, garantiscono un'intuitiva interpretazione delle operazioni di modifica e di gestione ed accesso alle funzioni.

Di seguito viene riportata la classificazione dei gruppi parametri principali:

- impostazione parametri di base
- monitor parametri e variabili di funzionamento
- parametrizzazione motore / inverter e impostazione limiti di sistema
- parametrizzazione Ingressi / Uscite
- parametrizzazione funzioni e parametri di regolazione
- parametrizzazione funzioni dedicate

Menu de Programmation

 La structure de programmation du variateur AVy, permet d'exécuter la configuration du système et le paramétrage du moteur de manière simple et rationnelle.

Les paramètres du variateur, divisés par type de fonction, assurent une interprétation intuitive des opérations de modification et de gestion, ainsi que l'accès aux fonctions.

Vous trouverez ci-après la classification des groupes des paramètres principaux :

- configuration des paramètres de base
- moniteur des paramètres et des variables de fonctionnement
- paramétrage du moteur / variateur et configuration des limites du système
- paramétrage des Entrées / Sorties
- paramétrage des fonctions et des paramètres de régulation
- paramétrage des fonctions spéciales

Programmiermenü

 Die Programmierungsstruktur des Frequenzumrichters AVy ermöglicht eine einfache und rationelle Systemkonfiguration und Motorparametrierung.

Die entsprechend ihrer Funktionsart unterteilten Parameter gewährleisten logische Änderungs- und Verwaltungsoperationen sowie einfachen Zugang zu den Funktionen.

Einteilung der Hauptparametergruppen:

- Einstellung Grundparameter
- Überwachung von Betriebsvariablen
- Parametrierung Motor / Frequenzumrichter und Systemgrenzeinstellung
- Parametrierung Eingänge / Ausgänge
- Parametrierung Funktionen und Regelungsparameter
- Parametrierung komplexe Funktionen.

Menú de Programación

 La estructura de programación del inverter AVy, permite monitorizar la configuración del sistema y la parametrización de motor de forma simple y racional.

Los parámetros del inverter se subdividen por tipología de funciones, garantizan una interpretación intuitiva de las operaciones de modificación y gestión así como de acceso a las funciones.

A continuación indicamos la clasificación de los grupos de parámetros principales:

- ajuste de los parámetros base
- monitorización de los parámetros y variables de funcionamiento
- parametrización del motor / inverter y ajuste de los límites del sistema
- parametrización de las Entradas/Salidas
- parametrización de las funciones y parámetros de regulación
- parametrización de las funciones dedicadas

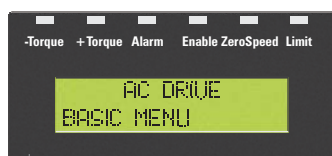

Example of keypad display for the entire AVy range
Esempio visualizzazione tastierino, per tutta linea AVy
Exemple de visualisation du clavier de paramétrage, pour toute la ligne AVy.
Beispiel Bedieneinheit-Anzeige, für die gesamte AVy-Serie.
Ejemplo de visualización del teclado, para toda la línea AVy.

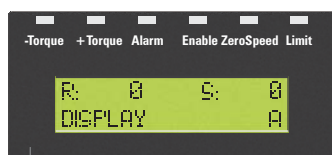

Example of keypad display for the -4A and -5 ranges only
Esempio visualizzazione tastierino, solo per linea "-4A" e "-5".
Exemple de visualisation du clavier de paramétrage, seulement pour ligne "-4A" et "-5".
Beispiel Bedieneinheit-Anzeige, nur für die Serie "-4A" und "-5".
Ejemplo de visualización del teclado, sólo para la línea "-4A" y "-5".

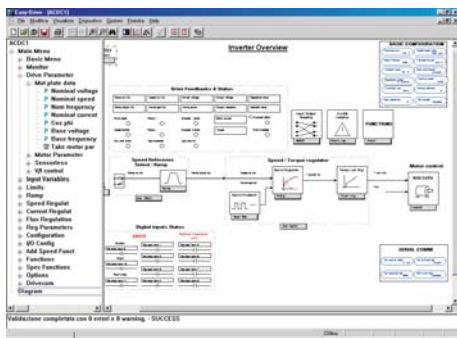

Easy Drive



EasyDrive

With **EasyDrive** configuration software you can program and use **AVy** series inverters via your PC.

Its intuitive programming methodology enables you not only to have complete management of the inverter, but also to have natural and immediate confidence in using it, at whatever level of use, thereby guaranteeing the development of rapid procedures for commissioning, optimisation and diagnostics on the system.

EasyDrive runs in a standard Windows environment, providing dialog boxes and toolbars, both for programming the inverter and managing and saving the actual configuration files.

This configuration software can be installed on any PC running Windows 95 or later. **EasyDrive** is included on the CD inside your drive pack.

The following operations can be performed using this configuration software:

- RS485 serial communication using Modbus RTU or Jbus protocol
- setting parameters via main menus based on a tree structure
- read and write operations involving all parameters/commands
- offline user file configuration
- online programming in a graphical environment
- parameter download and upload procedure
- user file archiving
- guided programming procedure for commissioning using a Wizard function
- graphic display of variables via a "Trend recorder" oscilloscope function
- multi-drop network management with up to 32 inverters

PlayGround Area (this function is only available for the **AVy...-4A** and **AVy...-5** ranges)

Using the **EasyDrive** configuration software you can access the advanced programming area known as the **PlayGround Area**.

In this mode, a library of over 100 developed or pre-defined function blocks, allow you to implement complex control solutions by combining logical/mathematical, comparison or custom functions, thereby creating the right application setup to suit your system's requirements.



EasyDrive

Il software di configurazione **EasyDrive** consente di programmare ed utilizzare gli inverter della serie **AVy** tramite PC.

Le intuitive modalità di programmazione, oltre a consentire una totale gestione dell'inverter, permettono a qualsiasi livello di utenza una facile ed immediata confidenza di impiego, garantendo rapide procedure di messa in servizio, ottimizzazione e diagnostica.

EasyDrive lavora in tipico ambiente Windows, proponendo quindi finestre di dialogo e barre degli strumenti, sia per la programmazione dell'inverter che per la gestione ed il salvataggio degli stessi files di configurazione.

Il configuratore è installabile su PC con sistema operativo Windows 95 e successivi. **EasyDrives** è incluso nel cd-rom presente all'interno della confezione del drive.

Mediante il configuratore, saranno quindi possibili le seguenti operazioni:

- comunicazione seriale RS485 mediante protocollo Modbus RTU o Jbus
- impostazione dei parametri mediante struttura ad albero dei menu principali
- lettura e scrittura di tutti i parametri / comandi
- configurazione file utente off-line
- programmazione on-line in ambiente grafico
- procedura di download e upload parametri
- archiviazione dei file utente
- procedura di programmazione guidata per la messa in servizio mediante funzione "Wizard"
- visualizzazione grafica delle variabili attraverso funzione di oscilloscopio "Trend recorder"
- gestione in rete multidrop fino a 32 inverter

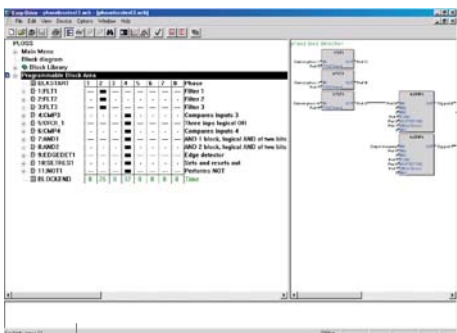

PlayGround Area

PlayGround Area (Funzione disponibile solo per linea **AVy...-4A** e **AVy...-5**)

Tramite il configuratore **EasyDrive**, è possibile accedere all'area di programmazione evoluta denominata **PlayGround Area**.

Tale modalità, grazie ad una libreria con oltre 100 blocchi funzione composti o predefiniti, consente di realizzare soluzioni di controllo complesse mediante la combinazione di funzioni logico/matematiche, di comparazione o funzioni custom, creando a seconda delle esigenze del sistema il proprio Setup applicativo.

 **EasyDrive**

Le logiciel de configuration **EasyDrive** permet de programmer et d'utiliser les variateurs de la série **AVy** par le biais d'un PC.

En plus de permettre une gestion complète du variateur, les modalités intuitives de programmation assurent une grande facilité d'utilisation à quelque niveau que ce soit, garantissant ainsi des procédures rapides de mise en service, d'optimisation et de diagnostic.

EasyDrive fonctionne dans le milieu Windows type, il propose donc des fenêtres de dialogue et des barres d'outils, pour la programmation du variateur ainsi que pour la gestion et la sauvegarde des fichiers de configuration.

Le configurateur peut être installé sur un PC avec un système d'exploitation Windows 95 et ses modifications.

EasyDrives est fourni dans le cd-rom se trouvant à l'intérieur de l'emballage du drive.

A l'aide du configurateur, il sera donc possible d'effectuer les opérations suivantes :

- communication série RS485 à l'aide du protocole ModBus RTU ou Jbus
- configuration des paramètres par le biais de la structure à arborescence des menus principaux
- lecture et écriture de tous les paramètres / commandes
- configuration fichiers utilisateur off-line
- programmation on-line dans le milieu graphique
- procédure de déchargement et de chargement des paramètres
- archivage des fichiers utilisateur
- procédure de programmation guidée pour la mise en service par le biais de la fonction "Wizard"
- visualisation graphique des variables par le biais de la fonction d'oscilloscope "Trend recorder"
- gestion en réseau multi-boucle, jusqu'à 32 variateurs

PlayGround Area (Fonction disponible uniquement pour ligne AVy...-4A et AVy...-5)

A l'aide du configurateur EasyDrive, il est possible d'accéder à la zone de programmation évoluée appelée **PlayGround Area**.

Cette modalité, grâce à une bibliothèque ayant plus de 100 blocs fonction composés et prédéfinis, permet de réaliser des solutions de contrôle complexes grâce à la combinaison de fonctions logiques/mathématiques, de comparaison ou de fonctions custom, en créant selon les exigences du système son propre Setup d'application.

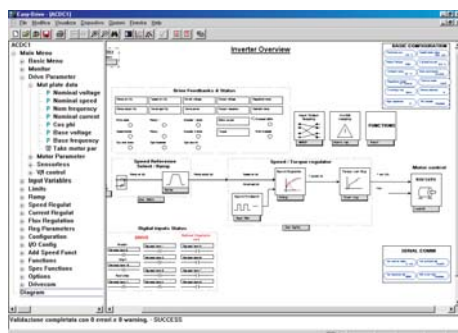

Easy Drive

 **EasyDrive**

Die Konfigurationssoftware **EasyDrive** ermöglicht die Programmierung und Verwendung der Frequenzrichter der Serie **AVy** über PC.

Die klare Programmstruktur ermöglicht die komplette Parametrierung des Frequenzrichters und bietet eine einfache, direkte Bedienung. Eine rasche Inbetriebnahme, Optimierung und Fehlersuche ist gewährleistet.

EasyDrive arbeitet in einer typischen Windows-Umgebung und bietet somit Dialogfenster und Werkzeugleisten sowohl für die Umrichterprogrammierung als auch für die Verwaltung und Speicherung der Konfigurationsdateien.

Der Konfigurator kann auf einem PC mit Betriebssystem Windows 95 und höher installiert werden.

EasyDrive wird auf einer beiliegenden CD-ROM mitgeliefert.

Mit dem Konfigurator können folgende Operationen durchgeführt werden:

- Serielle RS485 Kommunikation über Modbus RTU oder Jbus Protokoll
- Parametereinstellung durch Hauptmenüs mit Baumstruktur
- Lesen und Schreiben aller Parameter / Befehle
- Dateikonfiguration Offline-Benutzer
- Online-Programmierung in graphischer Umgebung
- Parameter-Download- und Uploadverfahren
- Benutzerdateiarchivierung
- Angeleitetes Programmierverfahren für Inbetriebnahme durch "Wizard"-Funktion
- Graphische Variablenanzeige über die Oszilloskopfunktion "Trend recorder"
- Verwaltung von bis zu 32 Frequenzrichtern im Multidrop-Netz
- Suchfunktion nach Parameternamen

PlayGround Area

(nur für die Serien AVy...-4A und AVy...-5 erhältlich)

Über den Konfigurator EasyDrive ist der Zugriff auf den höheren Programmierbereich **PlayGround Area** möglich.

Dank einer Bibliothek mit mehr als 100 zusammengesetzten oder vordefinierten Funktionsblöcken ermöglicht dieser Modus die Umsetzung komplexer Regelungen durch die Kombination von anwendungsbezogenen logisch/mathematischer Funktionen, indem entsprechend den Systemansprüchen ein eigenes Anwendungssetup kreiert wird.

 **EasyDrive**

El software de configuración **EasyDrive** está diseñado para la programación y uso de los inverter de la **AVy** a través de PC.

La intuitiva modalidad de programación, además de permitir una gestión total del inverter, permite a cualquier nivel la utilización una fácil e inmediata, garantizando unos procedimientos rápidos de puesta en marcha, optimización y diagnóstico.

EasyDrive se ejecuta en el típico entorno Windows, ofreciendo ventanas, cuadros de diálogo y barras de herramientas

de los instrumentos, tanto para la programación del inverter como para la gestión y conservación de los archivos de usuario de la configuración.

El configurador es instalable en PC que funcionen con los sistemas operativos Windows 95 y posteriores.

EasyDrives se incluye en el CD-ROM del controlador.

Mediante el configurador, será posible realizar las siguientes operaciones:

- comunicación serie RS485 por medio del protocolo Modbus RTU o Jbus
- ajustes de los parámetros con estructura de árbol a través del menú principal
- lectura y escritura de todos los parámetros / comandos
- configuración off-line de los archivos de salida
- programación on-line en entorno gráfico
- procedimiento de download y upload de parámetros
- archivación de los archivos de salida
- procedimiento de programación asistida para la puesta en servicio por medio de la función de asistente, "Wizard"
- visualización gráfica de las variables a través de funciones de osciloscopio "Trend recorder"
- gestión en red multidrop de hasta 32 inversores

Área PlayGround

(Función sólo disponible para líneas AVy...-4A y AVy...-5)

A través del configurador EasyDrive, se puede acceder al área de programación avanzada denominada **Área PlayGround**.

Esta modalidad, gracias a una librería con más de 100 bloques de funciones compuestas o predefinidas, permite realizar soluciones de control complejas mediante la combinación de funciones lógicas/matemáticas, comparaciones o funciones personalizadas, creando en función de las exigencias del sistema el propio Setup de aplicación.

Introduzione

Using the AVy ARTDrive inverter, with its host of advanced features and configurable, intuitive control logic, you can exercise control in a flexible, cost-effective way over the very latest industrial control and process systems.

Designed to meet the needs of OEMs, panel builders and system integrators, AVy provides hardware solutions and configurations as standard allowing you to use it immediately, easily and fully.

Just as suitable for single-motor configurations as for controlling complex systems, AVy offers with the APC100y card the benefits of SIEL's application experience, so that you can successfully implement control architectures in such areas as winding systems, positioning operations, electrical axle control and virtually limitless machine customisations.



L'inverter ARTDrive "AVy" grazie, alle molteplici funzioni avanzate e ad una logica di regolazione configurabile ed intuitiva, consente di realizzare in modo flessibile ed economico, le regolazioni dei più moderni sistemi industriali di controllo e di processo.

Pensato per soddisfare le esigenze di OEM, quadristi di automazione e system integrators, "AVy" nasce già integrando come standard, soluzioni e configurazioni HW, che ne consentono un impiego immediato, facile e completo.

Ideale sia per configurazioni monomotore che per controlli di sistemi complessi, AVy offre con la scheda APC100y i vantaggi dell'esperienza applicativa SIEL, consentendo di realizzare con successo architetture di regolazione complesse quali: sistemi di avvolgitura, posizionamenti, controllo in asse elettrico e personalizzazioni di macchina praticamente illimitate.

Introduction

Le variateur ARTDrive "AVy", grâce aux multiples fonctions de pointe et à une logique de régulation configurable et intuitive, permet de réaliser en souplesse et économiquement les régulations des systèmes modernes de contrôle et de procédé les plus modernes.

Conçus pour répondre aux exigences des OEM, des fabricants d'armoires d'automation et de systèmes intégrateurs, "AVy" est conçu en intégrant déjà en standard, les solutions et les configurations HW, qui en permettent une utilisation immédiate, facile et complète.

Idéale tant pour les configurations à un seul moteur que pour les contrôles de systèmes complexes, AVy offre avec la carte APC100y les avantages de l'expérience appliquée de SIEL, permettant de réaliser avec succès des architectures de régulation complexes comme : des systèmes d'enroulement, de mise en place, de contrôle sur axe électrique et des personnalisations de machines pratiquement illimitées.

Einleitung

Durch seine zahlreichen fortschrittlichen Funktionen und einer konfigurierbaren, einfachen Regelungslogik ermöglicht der Frequenzumrichter ARTDrive "AVy" die flexible und wirtschaftliche Realisierung von Regelungen für die modernsten industriellen Steuerungs- und Prozesssysteme.

Der "AVy" wurde konzipiert, um allen Ansprüchen von Maschinenherstellern, Automationstechnikern und Systemintegratoren gerecht zu werden. Seine Standardausstattung umfasst bereits Lösungen und HW-Konfigurationen, die einen unmittelbaren, einfachen und kompletten Einsatz ermöglichen.

Ideal sowohl für Konfigurationen mit einem Antrieb als auch für komplexe Systeme – mit der APC100y-Karte bietet der AVy alle Vorteile der Anwendungserfahrung von SIEL. Er ermöglicht die erfolgreiche Realisierung komplexer Regelungsarchitekturen wie Wickelsysteme, Positionierung, Regelungen mit elektrischer Welle und praktisch unbeschränkte kundenbezogene Lösungen.

Introducción

El inverter ARTDrive "AVy" gracias a sus múltiples funciones avanzadas y a una lógica de regulación configurable e intuitiva, permite realizar de forma flexible y sencilla, las regulaciones de los más modernos sistemas industriales de control y de proceso.





Pensado para satisfacer las exigencias de los OEM, fabricantes de cuadros de control para automatizaciones e integradores de sistemas, "AVy" surge integrando como equipamiento estándar, soluciones e configuraciones HW, que permiten realizar una instalación inmediata fácil y completa.

Ideal tanto para configuraciones monomotor como para el control de sistemas complejos, AVy ofrece con la tarjeta APC100y las ventajas de la experiencia de las aplicaciones SIEL, consiguiendo realizar con éxito arquitecturas de regulación complejas como por ejemplo: sistemas de devanado, posicionamiento, control en ejes eléctricos y personalización de maquinaria prácticamente ilimitado.

Identification Code

Codice di Identificazione
Code d'Identification
Identifikationscode
Siglas Identificación Producto



					
AVy	ARTDrive AC Inverter, 3 phase input voltage	ARTDrive Inverter CA, alimentazione trifase	ARTDrive Variateur CA, alimentation triphasée	ARTDrive Drehstrom-Frequenzumrichter dreiphasige	ARTDrive Inverter CA, alimentación trifásica
①	Enclosure dimension identification	Identificazione della dimensione	Taille du boîtier	Versorgung Baugröße	Identificación de las dimensiones
②	Inverter rated output power AVy: I.e.: 055 = 5.5kW AVy...-5: I.e.: 005 = 5Hp	Potenza nominale in uscita AVy: Es.: 055 = 5.5kW AVy...-5: Es.: 005 = 5Hp	Puissance nominale de sortie AVy: Es: 055 = 5.5kW AVy...-5: Es.: 005 = 5Hp	Ausgangsleistung AVy: z.B.: 055 = 5.5kW AVy...-5: z.B.: 005 = 5Hp	Potencia nominal de salida AVy: Es.: 055 = 5.5kW AVy...-5: Es.: 005 = 5Hp
③	X = KCS leds module K = Programming keypad KBS	X = Modulo a led KCS K = Tastierino di programmazione KBS	X = Module à diodes (LED) KCS K = Clavier de programmation KBS	X = KCS LED-Modul K = Programmierungs-Bedieneinheit KBS	X = modulo de leds KCS K = Teclado de programación KBS
④	X = without integrated braking circuit B = with integrated braking circuit	X = senza unità di frenatura interna B = con unità di frenatura interna	X = sans unité de freinage interne B = avec unité de freinage interne	X = ohne Bremskreis B = integrierter Bremskreis	X = suministro sin unidad de frenado integrada B = suministro con unidad de frenado integrada
⑤	X = Standard software	X = Software standard	X = Logiciel standard	X = Standardsoftware	X = Software estándar
⑥	[blank] = 230 ... 480V version -4A = 460V version -5 = 575V version -C/CP = compact version	[vuoto] = versione 230 ... 480V -4A = versione 460V -5 = versione 575V -C/CP = versione 400 ... 480V compatta	[vide] = version 230 ... 480V -4A = version 460V -5 = version 575V -C/CP = version 400 ... 480V compacte	[leer] = versione 230 ... 480V -4A = 460 V Ausführung -5 = 575 V Ausführung -C/CP = Ausführung 400 ... 480V kompakt	[vacío] = versión 230 ... 480V -4A = versión 460V -5 = versión 575V -C/CP = versión 400 ... 480V compacta

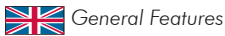

AVy and AVy...-4A range

- 3-phase power supply: 230Vac -15% ... 480Vac +10%, 50/60Hz up to 132kW (150Hp)
- Motor ratings from 0,75kW (0,75Hp) to 200kW (250Hp)
- **AVy** version with default power supply setting at 400 Vac, 50Hz
- **AVy...-4A** version with default power supply setting at 460Vac, 50Hz

AVy - C (Compact) range

- 3-phase power supply 400Vac -15% ... 480Vac ±10%, 50/60Hz ±5%
- Motor ratings: 250kW and 315kW (350Hp and 450Hp)
- Standard version with default power supply setting at 400Vac, 50Hz

AVy...-5 range

- 3-phase power supply: 575Vac ±10%, 50/60Hz ±5%
- Motor ratings from 2Hp to 200Hp
- Standard version with default power supply setting at 575Vac, 60Hz

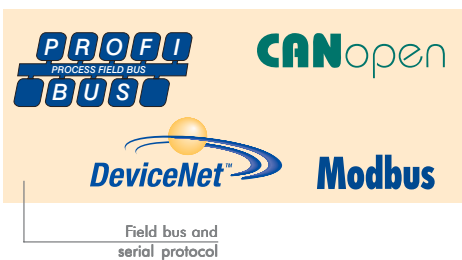

Standards and Marks

- CE:** complies with the EEC directive concerning low voltage equipment.
- UL, cUL:** complies with directives for the American and Canadian market.
- CSA:** complies with the directives for the Canadian market (only AGy...-5)
- EMC:** complies with the EEC directive - EN 61800-3:2004 concerning electromagnetic compatibility with the use of optional filters.



Control modes

- Closed Loop Flux Vector control:
 - sinusoidal encoder (speed accuracy: 0.01%)
 - digital encoder (speed accuracy: 0.02%)
- Flux Vector control without encoder feedback (sensorless) (speed accuracy: 0.1% above 100 rpm, 0.2% below 100 rpm)
- V/f scalar control (speed accuracy varies with motor slip)

Main control and regulation functions

- Output frequency:
 - 400 Hz for control with encoder feedback
 - 200 Hz for sensorless control
- Offline self-tuning: for speed-current-flux loops and motor data identification (possible with motor idle or rotating)
- Online self-tuning: motor parameter compensation according to variations in temperature AVy and AVy...-4A range
- Torque control: with built-in OR function for gradual switching between the speed and torque controllers
- Instantaneous overload 200% up to 132kW (150Hp)
- Overload capacity compliant with IEC 146 Class 1 and Class 2 (see the following tables for more details)
- I²t thermal protection for motor and drive
- Multi-speed function (with 7 programmable speeds)
- 5 independent, programmable ramps (linear and S-curve)
- Motor potentiometer function
- Motor "auto-capture" function
- Droop function
- Dual motor management
- PID function block
- Mains loss detection with controlled stop and/or power optimisation
- Virtual or remote I/O management

Standard supply configuration

- LCD programming keypad or LED diagnostics module
- Integrated inverter braking module:
 - standard for AVy and AVy...-4A range: up to 15kW (20Hp) and optionally up to 55kW (60Hp)
 - standard for AVy...-5 range: up to 20Hp and optionally up to 75Hp
- Integrated RS485 serial connection (ModBus RTU protocol)
- Standard inputs/outputs:
 - 3 programmable differential analogue inputs (voltage/current)
 - 2 programmable analogue outputs
 - 8 digital inputs:
 - AVy range: 4 non programmable + 4 programmable
 - AVy...-4A range: 8 programmable
 - AVy...-5 range: 8 programmable
 - 2 programmable digital outputs
 - 2 programmable relay outputs
- Integrated encoder input: sinusoidal 1Vpp (+5V) and digital TTL (+5V)
- Fieldbus Interfacer: ProfiBus, CANopen and DeviceNet (with optional card)
- EasyDrive, an advanced configuration software application for PC, including:
 - programming inverter function blocks in a graphical environment
 - user file archiving
 - guided programming procedure for commissioning using a Wizard function
 - graphic display of variables via a "Trend recorder" oscilloscope function
- "PlayGround Area" with over 100 programmable logical blocks for implementing complex controls using logical functions, mathematical operations or customised architectures (only for the AVy...-4A and AVy...-5 ranges)

Accessories (optional)

- Dedicated EMC filters (compliant with EEC Directive - EN61800-3:2004)
- Braking resistors (standardised for the whole range)
- Input and output inductors (standardised for the whole range)
- NEMA 1 protection kit
- Programming remote keypad kit

Environmental conditions

- Housing:** IP20 (NEMA1 optional)
IP54: up to size 15kW (20Hp) for heat sink mounted externally on cabinet.
- Operating temperature:** from 0°C to 40°C, from + 40°C to +50°C with derating.
- Storage temperature:** -25°C...+55°C (Class 1K4 – EN50178)
- Humidity:** from 5% to 85%, relative humidity (without condensation) or ice formation (Class 3K3 under EN50178)
- Altitude:** up to 2000 metres above sea level. Above 1000 metres, that the current is reduced by 1.2% for each additional 100 metres in altitude.

Linea "AVy" e "AVy...-4A"

- Alimentazione trifase: 230Vac -15% ... 480Vac +10%, 50/60Hz fino a 132kW (150Hp)
- Potenze motore da 0,75kW (0,75Hp) a 200kW (250Hp)
- Versione "AVy" con impostazione di default per alimentazioni a 400Vac, 50Hz
- Versione "AVy...-4A" con impostazione di default per alimentazioni a 460Vac, 50Hz

Linea "AVy - C (Compatto)"

- Alimentazione trifase 400Vac -15% ... 480Vac ±10%, 50/60Hz ±5%
- Potenze motore 250kW e 315kW (350Hp e 450Hp)
- Versione standard con impostazione di default per alimentazioni a 400Vac, 50Hz

Linea "AVy...-5"

- Alimentazione trifase 575Vac ±10%, 50/60Hz ±5%
- Potenze motore da 2Hp a 200Hp
- Versione con impostazione di default per alimentazioni a 575Vac, 60Hz



Norme e Marchi

- CE:** conforme alla direttiva CEE sugli apparecchi a bassa tensione.
- UL, cUL:** conforme alle direttive per il mercato Americano e Canadese.
- CSA:** conforme alle direttive per il mercato Canadese (solo linea "AGy...-5")
- EMC:** conforme alla direttiva CEE - EN 61800-3:2004, sulla compatibilità elettromagnetica con l'impiego dei filtri opzionali.

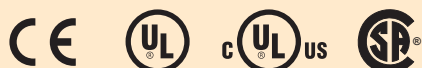

Modalità di controllo

- Controllo Vettoriale di Flusso ad anello chiuso:
 - encoder sinusoidale (precisione di velocità: 0,01%)
 - encoder digitale (precisione di velocità: 0,02%)
- Controllo Vettoriale di Flusso senza retroazione da encoder (Sensorless) (precisione di velocità: 0,1% sopra i 100rpm, 0,2% sotto i 100rpm)
- Controllo scalare V/f (precisione di velocità in funzione dello scorrimento del motore)

Funzioni di controllo e regolazione principali

- Frequenza di uscita:
 - 400Hz per controllo con retroazione da encoder
 - 200Hz in controllo Sensorless
- Autotaratura off-line: dei regolatori di velocità-corrente-flusso ed identificazione dati motore (possibile con motore fermo od in rotazione)
- Autotaratura on-line: compensazione dei parametri motore in funzione delle variazioni di temperatura
- Controllo di coppia: con funzione OR built-in, per commutazione graduale tra regolatore di velocità e regolatore di coppia
- Sovraccarico istantaneo al 200 % fino al 132kW (150Hp)
- Capacità sovraccarico secondo IEC 146 Classe 1 e Classe 2 (per maggiori dettagli vedere tabelle seguenti)
- Protezione termica I²t per motore e Drive
- Funzione Multivelocità (7 programmabili)
- 5 rampe indipendenti e programmabili (lineare ed a S)
- Funzione Motopotenziometro
- Funzione di riaggancio al volo motore
- Droop Function
- Gestione doppio motore
- Blocco funzione PID
- Gestione in caso di mancanza rete mediante: arresto controllato o/e ottimizzazione dell'energia.
- Gestione I/O virtuali o remote

Configurazione di Fornitura Standard

- Tastiera di programmazione LCD o modulo di diagnostica a led
- Modulo di frenatura integrato a bordo dell'inverter:
 - standard per linea AVy e AVy...-4A fino a 15kW (20Hp) e opzionale fino a 55kW (60Hp)
 - standard per linea AVy...-5 fino a 20Hp e opzionale fino a 75Hp
- Linea seriale RS485 integrata (protocollo ModBus RTU)
- Ingressi/Uscite standard:
 - 3 ingressi analogici differenziali programmabili (Tensione/Corrente)
 - 2 uscite analogiche programmabili
 - 8 ingressi digitali:
 - linea AVy: 4 non programmabili + 4 programmabili
 - linea AVy...-4A: 8 programmabili
 - linea AVy...-5: 8 programmabili
 - 2 uscite digitali programmabili
 - 2 uscite a relè programmabili
- Ingresso encoder integrato: sinusoidale 1Vpp (+5V) e digitale TTL (+5V)
- Interfacciamento con bus di campo: ProfiBus, CANopen e DeviceNet (con scheda opzionale)
- Software di configurazione evoluto per PC "EasyDrive" incluso:
 - programmazione in ambiente grafico dei blocchi funzione dell'inverter
 - archiviazione file utente
 - procedura di programmazione guidata per la messa in servizio mediante "Wizard"
 - visualizzazione grafica delle variabili e delle funzioni mediante "Trend recorder"
- "Playground Area" con oltre 100 blocchi logici programmabili, per la realizzazione di controlli complessi mediante funzioni logiche, operazioni matematiche od architetture personalizzate (solo per linea AVy...-4A e AVy...-5)

Accessori (Opzionali)

- Filtri EMC dedicati (in conformità alla direttiva CEE - EN 61800-3:2004)
- Resistenze di frenatura (normalizzate per l'intera gamma)
- Induttanze d'ingresso ed uscita (normalizzate per l'intera gamma)
- Kit per grado di protezione NEMA 1
- Kit per remotaggio tastiera di programmazione

Condizioni Ambientali

- Alloggiamento:** IP20 (NEMA1 opzionale)
IP54: fino alla taglia 15kW (20Hp), per dissipatore montato esterno al quadro.
- Temperatura di esercizio:** da 0°C a 40 °C, da + 40 °C a +50 °C con derating.
- Temperatura di immagazzinaggio:** -25°C...+55°C (Classe 1K4 - EN50178)
- Umidità:** da 5% a 85%, umidità relativa (senza condensa) o formazione di ghiaccio (classe 3K3 in accordo a EN50178)
- Altitudine:** fino a 2000 metri s.l.m.; oltre 1000 metri, la corrente deve essere ridotta del 1,2% ogni 100 metri di incremento.

 **Caractéristiques Générales**

Ligne "AVy" et "AVy...-4A"

- Alimentation triphasée : 230V_{ca} -15% - 480V_{ca} + 10%, 50/60Hz jusqu'à 132kW (150Hp)
- Puissances du moteur de 0,75kW(0,75Hp) à 200kW (250Hp)
- Version "Avy" avec configuration par défaut pour des alimentations à 400V, 50Hz
- Version "AVy...-4A" avec configuration par défaut pour des alimentations à 460V, 50Hz

Ligne "AVy - C (Compact)"

- Alimentation triphasée 400V -15% ... 480V ± 10%, 50/60Hz ± 5%
- Puissances du moteur 250kW et 315kW (350Hp et 450Hp)
- Version standard avec configuration par défaut pour des alimentations à 400V, 50Hz

Ligne "AVy...-5"

- Alimentation triphasée 575V ± 10%, 50/60Hz ± 5%
- Puissances du moteur de 2Hp à 200Hp
- Version avec configuration par défaut pour des alimentations à 575V, 60Hz



Normes et marques

- CE:** conformes à la directive CEE sur les appareils en basse tension.
- UL, cUL:** conformes aux directives pour le marché Américain et Canadien.
- CSA:** conformes aux directives pour le marché Canadien (seulement ligne "AGy...-5")
- EMC:** conformes à la directive CEE - EN 61800-3:2004, concernant la compatibilité électromagnétique avec l'utilisation des filtres en option.



Mode de contrôle

- Contrôle Vectoriel du Flux à boucle fermée :
 - codeur sinusoïdal (précision de la vitesse : 0,01%)
 - codeur digital (précision de la vitesse : 0,02%)
- Contrôle Vectoriel du flux sans rétroaction par codeur (Sensorless) (précision de la vitesse : 0,1% au-dessus de 100 t/mn, 0,2% au-dessous de 100 t/mn)
- Contrôle progressif V/f (précision de la vitesse en fonction du glissement du moteur)

Fonctions principales de contrôle et de régulation

- Fréquence de sortie :
 - 400Hz pour le contrôle avec rétroaction par codeur
 - 200Hz en contrôle Sensorless
- Calibrage automatique off-line : des régulateurs de vitesse-courant-flux et identification des données du moteur (possible avec moteur à l'arrêt ou moteur en phase de rotation)
- Calibrage automatique on-line : compensation des paramètres du moteur en fonction des variations de la température
- Contrôle du couple : à fonction OR built-in, pour commutation graduelle entre régulateur de vitesse et régulateur de couple
- Surcharge instantanée à 200 % jusqu'à 132kW (150Hp)
- Capacité de surcharge selon CIE 146 Classe 1 et Classe 2 (pour de plus amples informations, voir les tableaux suivants)
- Protection thermique I²t pour moteur et Drive
- Fonction multivitesse (7 programmables)
- 5 rampes indépendantes et programmables (linéaire et en S)
- Fonction Motopotentiomètre
- Fonction de redémarrage au vol du moteur
- Droop Function
- Gestion double moteur
- Blocage fonction PID
- Gestion en cas de coupure de secteur par : arrêt contrôlé et/ou optimisation de l'énergie.
- Gestion E/S virtuelles ou à distance

Configuration en fourniture standard

- Clavier de programmation LCD ou module de diagnostic à led
- Module de freinage intégré à bord du variateur :
 - standard pour ligne AVy et AVy...-4A jusqu'à 15kW (20Hp) et en option jusqu'à 55kW (60Hp)
 - standard pour ligne AVy...-5 jusqu'à 20Hp et en option jusqu'à 75Hp
- Ligne série RS485 intégrée (protocole Modbus RTU)
- Entrées/Sorties standards :
 - 3 entrées analogiques différentielles programmables (Tension/Courant)
 - 2 sorties analogiques programmables
 - 8 entrées digitales :
 - ligne AVy: 4 non programmables + 4 programmables
 - ligne AVy...-4A: 8 programmables
 - ligne AVy...-5: 8 programmables
 - 2 sorties digitales programmables
 - 2 sorties à relais programmables
- Entrée codeur intégré : sinusoïdal 1V_{pp} (+5V) et digital TTL (+5V)
- Interface avec bus de terrain : ProfiBus, CANopen et DeviceNet (avec carte optionnelle)
- Logiciel de configuration de pointe pour PC "EasyDrive" compris :
 - programmation dans le milieu graphique des blocs fonction du variateur
 - archivage des fichiers utilisateur
 - procédure de programmation guidée pour la mise en service par la "Wizard"
 - visualisation graphique des variables et des fonctions par "Trend recorder"
- "Playground Area" avec plus de 100 blocs logiques programmables, pour la réalisation de contrôles complexes à l'aide des fonctions logiques, d'opérations mathématiques ou d'architectures personnalisées (seulement pour la ligne AVy...-4A et AVy...-5)

Accessoires (Options)

- Filtres EMC spéciaux (conformes à la directive CEE - EN 61800-3:2004)
- Résistances de freinage (normalisées pour toute la gamme)
- Inductances d'entrée et de sortie (normalisées pour toute la gamme)
- Kit pour degré de protection NEMA 1
- Kit pour installation à distance de la console de programmation

Conditions d'environnement

- Logement:** IP20 (NEMA1 en option)
IP54: jusqu'à la grandeur 15kW (20Hp), pour dissipateur monté à l'extérieur de l'armoire.
- Température de service :** de 0°C à 40 °C, de + 40 °C à +50 °C avec déclassé.
- Température de stockage :** -25°C...+55°C (Classe 1K4 - EN50178)
- Humidité :** de 5% à 85%, humidité relative (sans condensation) ou formation de glace (classe 3K3 conformément à la norme EN50178)
- Altitude :** jusqu'à 2000 mètres au-dessus du niveau de la mer; au-delà de 1000 mètres, le courant doit être diminué de 1,2% tous les 100 mètres supplémentaires.

Standard Versions



Serie "AVy" und "AVy...-4A"

- Dreiphasige Versorgung: 230 V_{AC} -15 % ... 480 V_{AC} +10 %, 50/60 Hz bis 132 kW (150 Hp)
- Motorleistungen von 0,75 kW (0,75 Hp) bis 200 kW (250 Hp)
- Ausführung "AVy" mit Voreinstellung für 400 V_{AC}, 50 Hz Versorgungen
- Ausführung "AVy...-4A" mit Voreinstellung für 460 V_{AC}, 50 Hz Versorgungen

Serie "AVy - C (Kompakt)"

- Dreiphasige Versorgung 400 V_{AC} -15 % ... 480 V_{AC} ±10 %, 50/60 Hz ±5 %
- Motorleistungen 250 kW und 315 kW (350 Hp und 450 Hp)
- Standardausführung mit Voreinstellung für 400 V_{AC}, 50 Hz Versorgungen

Serie "AVy...-5"

- Dreiphasige Versorgung 575 V ±10 %, 50/60 Hz ±5 %
- Motorleistungen von 2 Hp bis 200Hp
- Ausführung mit Voreinstellung für 575 V_{AC}, 60 Hz Versorgungen



Normen und Marken

- CE:** entspricht der EG-Richtlinie über Geräte mit Niederspannung.
- UL, cUL:** entspricht den Richtlinien für den amerikanischen und kanadischen Markt.
- CSA:** entspricht den Richtlinien für den kanadischen Markt (nur für Serie "AGy...-5")
- EMC:** entspricht der EG-Richtlinie – EN 61800-3:2004 über die elektromagnetische Verträglichkeit mit dem Einsatz optionaler Filter.



Regelungsarten

- Vektorielle Flussregelung mit geschlossenem Regelkreis:
 - Sinusencoder (Drehzahlgenauigkeit: 0,01 %)
 - Digitalencoder (Drehzahlgenauigkeit: 0,02 %)
- Vektorielle Flussregelung ohne Encoderrückführung (Sensorless) (Drehzahlgenauigkeit: 0,1 % über 100 min⁻¹, 0,2 % unter 100 min⁻¹)
- Skalare U/f-Regelung (Drehzahlgenauigkeit in Funktion des Motorschlupfs)

Wichtigste Steuer- und Regelfunktionen

- Ausgangsfrequenz:
 - 400 Hz für Steuerung mit Encoderrückführung
 - 200 Hz bei Sensorless-Steuerung
- Inbetriebnahmefunktion: Adaption der Drehzahl-Strom-Flussregler und Motordatenidentifizierung (möglich bei still stehendem oder drehendem Motor)
- Online-Adaption: Anpassung der Motorparameter als Funktion der Temperaturänderungen
- Drehmomentregelung: mit eingebauter OR-Funktion für die schrittweise Umschaltung zwischen Drehzahlregler und Drehmomentregler
- Kurzzeitige Überlast von 200 % bis 132 kW (150 Hp)
- Überlastfähigkeit gemäß IEC 146 Klasse 1 und Klasse 2 (für nähere Details siehe folgende Tabellen)
- Wärmeschutz I²t für Motor und Antrieb
- 7 programmierbare Drehzahlen
- 5 unabhängige, programmierbare Rampen (linear und s-förmig)
- Funktion Motorpotentiometer
- Aufschalten auf drehenden Motor
- Lastaufteilung bei mechanisch gekoppelten Motoren
- 2 Motorparametersätze
- zusätzlicher, frei programmierbarer PID-Regler
- Verhalten bei Netzausfall programmierbar: gesteuertes Anhalten und/oder Energieoptimierung.
- Einbindung virtueller oder entfernt liegender I/O (Feldbus)

Konfiguration Standardlieferung

- LCD-Programmierbedieneinheit oder LED-Diagnosemodul
- Im Frequenzumrichter integriertes Bremsmodul:
 - Standard für Serie AVy und AVy...-4A bis 15 kW (20 Hp) und optional bis 55 kW (60 Hp)
 - Standard für Serie AVy...-5 bis 20 Hp und optional bis 75 Hp
- Integrierte serielle RS485 Leitung (ModBus RTU Protokoll)
- Standardeingänge/-ausgänge:
 - 3 programmierbare Differential-Analogeingänge (Spannung/Strom)
 - 2 programmierbare Analogausgänge
 - 8 Digitaleingänge:
 - Serie AVy: 4 nicht programmierbare + 4 programmierbare
 - Serie AVy...-4A: 8 programmierbare
 - Serie AVy...-5: 8 programmierbare
 - 2 programmierbare Digitalausgänge
 - 2 programmierbare Relaisausgänge
- Integrierter Encodereingang: Sinusencoder 1V_{pp} (+5 V) und Digitalencoder TTL (+5 V)
- Feldbusschnittstelle: ProfiBus, CANopen und DeviceNet (mit Optionskarte)
- Konfigurationssoftware für PC "EasyDrive" inklusive:
 - Programmierung der Frequenzumrichter-Funktionsblöcke in graphischer Umgebung
 - Benutzerdateiarchivierung
 - Inbetriebnahme durch "Wizard"-Funktion
 - Graphische Anzeige der Variablen über die Oszilloskopfunktion "Trend recorder"
- "Playground Area" mit mehr als 100 programmierbaren logischen Blöcken; für die Realisierung komplexer Regelungen durch logische Funktionen, mathematische Operationen oder anwendungsbezogene Architekturen (nur für Serien AVy...-4A und AVy...-5)

Zubehörteile (optional)

- spezielle EMV-Filter (gemäß EG Richtlinie – EN 61800-3:2004)
- Bremswiderstände (für die gesamte Produktpalette genormt)
- Eingangs- und Ausgangsnetzdröseln (für die gesamte Produktpalette genormt)
- Montagesatz für Schutzgrad NEMA 1
- Montagesatz für externe Installation der Programmier-Bedieneinheit

Umgebungsbedingungen

- Gehäuse:** IP20 (NEMA1 optional)
IP54: bis Größe 15 kW (20 Hp), für extern an der Schalttafel montierten Kühlkörper.
- Betriebstemperatur:** von 0° C bis 40° C, von + 40° C bis +50° C mit Leistungsreduktion.
- Lagerungstemperatur:** -25° C...+55° C (Klasse 1K4 – EN50178)
- Feuchtigkeit:** von 5 % bis 85 %, relative Feuchtigkeit (ohne Betauung) oder Eisbildung (Klasse 3K3 entsprechend EN50178)
- Installationshöhe:** bis zu 2000 Metern ü.d.M.; über 1000 Metern, muss der Strom pro 100 Höhenmeter um 1,2 % verringert werden.

 Características Generales

Línea "AVy" y "AVy...-4A"

- Alimentación trifásica: 230Vac -15% ... 480Vac +10%, 50/60Hz hasta 132kW (150CV)
- Potencias de motores desde 0,75kW (0.75CV) hasta 200kW (250CV)
- Versiones "AVy" con configuración por defecto para la alimentación a 400V, 50Hz
- Versiones "AVy...-4A" con configuración por defecto para la alimentación a 460V, 50Hz

Línea "AVy - C (Compacto)"

- Alimentación trifásica 400V -15% ... 480V ±10%, 50/60Hz ±5%
- Potencias de motor de 250kW y 315kW (350CV y 450CV)
- Versiones "AVy" con configuración por defecto para la alimentación a 400V, 50Hz

Línea "AVy...-5"

- Alimentación trifásica 575V ±10%, 50/60Hz +/5%
- Potencias de motores desde 2CV hasta 200CV
- Versiones "AVy" con configuración por defecto para la alimentación a 575V, 60Hz



Normas y marcas

CE: de acuerdo con la directiva CEE en los equipos de baja tensión

UL, cUL: en cumplimiento de las directivas para el mercado Americano y Canadiense

CSA: en cumplimiento de las directivas para el Canadiense (sólo línea "AVy...-5")

EMC: de acuerdo con la directiva CEE - EN 61800-3:2004, sobre la compatibilidad electromagnética con el empleo de filtros opcionales.



Modalidad de control

- Control vectorial del flujo en bucle cerrado:
 - encoder sinusoidal (precisión de velocidad: 0,01%)
 - encoder sinusoidal (precisión de velocidad: 0,02%)
- Control vectorial de flujo sin realimentación de encoder (Sensorless) (precisión de velocidad: 0,1% por debajo de 100rpm, 0,2% por debajo de 100rpm)
- Control escalon V/f (precisión de velocidad en función del deslizamiento del motor)

Función de control y regulaciones principales

- Frecuencia de salida:
 - 400Hz por control con realimentación de encoder
 - 200Hz en control Sensorless
- Calibración automática off-line: de los reguladores de velocidad-intensidad-flujo e identificación de datos de los motores (posible con motores parados y en rotación)
- Calibración automática on-line: compensación de los parámetros de los motores en función de las variaciones de temperatura
- Control de par: con función OR integrada, por comunicación gradual de los reguladores de velocidad y de los reguladores de par
- Sobrecarga instantánea del 200 % hasta 132kW (150CV)
- Capacidad de sobrecarga según las directrices IEC 146 Clase 1 y Clase 2 (para mayores detalles consulte la tabla siguiente)
- Protección térmica I²t para motor y Drive
- Función multivelocidad (7 programaciones)
- 5 rampas independientes y programables (lineales y en S)
- Función Motopotenciometro
- Función de reenganche del motor al vuelo
- Función Droop
- Gestión doble motor
- Bloqueo función PID
- Gestión en caso de fallo red mediante: parada controlada y/o optimización de la energía
- Gestiones de E/S virtuales o remotas

Configuración de entrega estándar

- Teclado de programación LCD o módulo de diagnóstico por leds
- Módulo de freno integrado en el propio inverter:
 - estándar por línea AVy y AVy...-4A hasta 15kW (20CV) y opcional hasta 55kW (60CV)
 - estándar por línea AVy...-5 hasta 20CV y opcional hasta 75CV
- Línea serie RS485 integrada (protocolo Modbus RTU)
- Entradas/Salidas estándar:
 - 3 entradas analógicas diferenciales programables (Tensión/Intensidad)
 - 2 salidas analógicas programables
 - 8 entradas digitales:

- línea AVy:	4 no programables + 4 programables
- línea AVy...-4A:	8 programables
- línea AVy...-5:	8 programables
 - 2 salidas digitales programables
 - 2 salidas de relé programables
- Entrada de encoder integrada: sinusoidal 1Vpp (+5V) y digital TTL (+5V)
- Interfaz con bus de campo: ProfiBus, CANopen y DeviceNet (con tarjeta opcional)
- Software de configuración avanzado para PC "EasyDrive" incluido:
 - programación en entorno gráfico de los bloques de funciones del inverter
 - archivación de los archivos de salida
 - procedimiento de programación asistida para la puesta en servicio por medio de la función de asistente, "Wizard"
 - visualización gráfica de las variables y las funciones a través de "Trend recorder"
- "Playground Area" con más de 100 bloques lógicos programables, para la realización de operaciones de control complejo mediante funciones lógicas, operaciones matemáticas o arquitecturas personalizadas (sólo para la línea AVy...-4A y AVy...-5)

Accesorios (Opcionales)

- Filtros EMC dedicados (según la normativa europea (CEE - EN 61800-3:2004)
- Resistencia de frenado (normalizada para toda la gama)
- Inductancia de entrada y salida (normalizada para toda la gama)
- Kit para el grado de protección NEMA 1
- Kit para teclado de programación remota

Condiciones ambientales

Alojamiento: IP20 (NEMA1 opcional)
IP54: hasta el corte 15kW (20CV), para disipador montado de forma externa al cuadro.

Temperatura de ejercicio: de 0°C a 40 °C , de + 40 °C a +50 °C con reducción.

Temperatura de almacenamiento: -25°C...+55°C (Clase 1K4 – EN50178)

Humedad: del 5% al 85%, humedad relativa (sin condensación) o formación de hielo (clase 3K3 en cumplimiento de la normativa EN50178)

Altura: hasta 2000 metros por encima del nivel del mar; para altitudes superiores 1000 m asegurarse de que la corriente se reduce un 1,2% por cada 100 metros de altura adicionales.

Standard Versions

Scelta dell'Inverter
Sélection du Variateur
Wahl des Frequenzumrichters
Selección del Convertidor de
Frecuencia



Co-ordination of the nominal power rating for a motor with the type of inverter that is referred to in the table will require use of motors that operate at a voltage corresponding to the nominal values of the power supply network.

For motors that operate at other voltages, the type of inverter that is selected will depend on the nominal current of the motor to be controlled.

The combination put forward in the table, therefore reflects, as a function of the power supply voltage, the value of current the drive is able to supply operating conditions (IEC146 Class 1) and under overload conditions (IEC146 Class 2), i.e.:

IEC 146 Class 1: continuous operation with maximum overload = $I_{2N} \times 1.36$ for 60 seconds

IEC 146 Class 2: continuous operation at 0.91% of I_{2N} with maximum overload = $0.91 I_{2N} \times 1.5$ for 60 seconds every 5 minutes

Analogous dimensioning criteria are applicable for any operations to which additional downgrading factors are applicable:

KV Power supply voltage

KT Ambient temperature

KF Switching frequency

Data:	Output	Input
AVy & AVy...-4A	table on page 16	table on page 17
AVy...-C/CP	table on page 18	table on page 18
AVy...-5	table on page 19	table on page 20



Il coordinamento delle potenze nominali del motore con il tipo di inverter riportato in tabella, prevede l'impiego di motori con tensione nominale corrispondente alla nominale della rete di alimentazione.

Per motori con tensione differente, la scelta dell'inverter dovrà essere effettuata in base alla corrente nominale del motore stesso.

L'abbinamento suggerito in tabella, riporta quindi in funzione della tensione di alimentazione, il valore di corrente erogabile dal drive in condizioni di funzionamento continuativo (IEC146 Classe1) ed in condizioni di sovraccarico (IEC146 Classe 2), ovvero:

IEC 146 Classe 1: servizio continuativo con sovraccarico max = $I_{2N} \times 1,36$ per 60 secondi

IEC 146 Classe 2: servizio continuativo allo 0,91% di I_{2N} con sovraccarico max = $0,91 I_{2N} \times 1,5$ per 60 secondi ogni 5 minuti

Criteri di dimensionamento analoghi, vengono applicati per operazioni con fattori di declassamento addizionali:

KV Tensione di alimentazione

KT Temperatura ambiente

KF Frequenza di switching

Dati:	d'Uscita	d'Ingresso
AVy & AVy...-4A	vedere pagina 16	vedere pagina 17
AVy...-C/CP	vedere pagina 18	vedere pagina 18
AVy...-5	vedere pagina 19	vedere pagina 20



La coordination des puissances nominales du moteur avec le type du variateur figurant dans le tableau, prévoit l'utilisation de moteurs ayant une tension nominale correspondant à la tension nominale du réseau d'alimentation.

Pour les moteurs ayant une tension différente, la sélection du variateur doit être effectuée en fonction du courant nominal du moteur.

La sélection suggérée dans le tableau, indique, en fonction de la tension d'alimentation, la valeur du courant fourni par le variateur dans des conditions d'un service continu (IEC146 Classe1) et dans des conditions de surcharge (IEC146 Classe 2), c'est-à-dire :

IEC 146 Classe 1: service continu avec une surcharge maxi = $I_{2N} \times 1,36$ pendant 60 secondes

IEC 146 Classe 2: service continu à 0,91% de I_{2N} avec une surcharge maxi = $0,91 I_{2N} \times 1,5$ pendant 60 secondes toutes les 5 minutes

Des critères de dimensionnement analogues sont appliqués pour les opérations avec des facteurs de déclassement supplémentaires :

KV Tension d'alimentation

KT Température ambiante

KF Fréquence de commutation

Caractéristiques:	Sortie	Entrée
AVy & AVy...-4A	tableau page 16	tableau page 17
AVy...-C/CP	tableau page 18	tableau page 18
AVy...-5	tableau page 19	tableau page 20

 Die angegebene Motornennleistung gilt bei Übereinstimmung der Motornennspannung mit der Netz-Nennspannung.

Für Motoren mit einer anderen Spannung muss der Frequenzumrichter ausgehend vom Motor-Nennstrom gewählt werden.

Die laut Tabelle empfohlene Kombination zeigt daher den vom Antrieb je nach Versorgungsspannung lieferbaren Stromwert, unter kontinuierlichen Betriebsbedingungen (IEC146 Klasse1) und unter Überlastbedingungen (IEC146 Klasse 2):

IEC 146 Klasse 1: kontinuierlicher Betrieb mit max. Überlast = $I_{2N} \times 1,36$ für 60 Sekunden

IEC 146 Klasse 2: kontinuierlicher Betrieb mit 0,91% von I_{2N} mit max. Überlast = $0,91 I_{2N} \times 1,5$ für 60 Sekunden alle 5 Minuten

Weitere Bemessungskriterien werden für den Betrieb mit zusätzlichen Anpassungsfaktoren angewendet:

KV Versorgungsspannung

KT Umgebungstemperatur

KF Schaltfrequenz

	Ausgangsdaten	Eingangsdaten
AVy & AVy...-4A	Tabelle auf Seite 16	Tabelle auf Seite 17
AVy...-C/CP	Tabelle auf Seite 18	Tabelle auf Seite 18
AVy...-5	Tabelle auf Seite 19	Tabelle auf Seite 20

 La coordinación de la potencia nominal del motor con el tipo de inverter al que se refiere la tabla, requerirá el uso de motores que operen con una tensión nominal correspondiente a los valores nominales del resto de alimentación.

Para motores que operen con otras tensiones, el tipo de inverter seleccionado, debería depender de la intensidad nominal del motor en cuestión

La combinación reflejada en la siguiente tabla refleja, en función de la tensión de alimentación, el valor de corriente que el equipo es capaz de suministrar bajo continuas condiciones de operación (IEC 146 Clase 1) y bajo condiciones de sobrecarga (IEC146 Clase 2), por ejemplo:

IEC 146 Clase 1: operación continuada con sobrecarga máxima = $I_{2N} \times 1,36$ en 60 segundos

IEC 146 Clase 2: operación continuada a 0,91% de I_{2N} con sobrecarga máxima = $0,91 I_{2N} \times 1,5$ en 60 segundos cada 5 minutos

Se aplica un criterio de dimensiones análogas aplicable en cada operación en la qual los factores degradantes sean aplicables:

KV Tensión de alimentación

KT Temperatura ambiente

KF Frecuencia de arranque

	Data:	Output data	Input data
AVy & AVy...-4A		tabla en la página 16	tabla en la página 17
AVy...-C/CP		tabla en la página 18	tabla en la página 18
AVy...-5		tabla en la página 19	tabla en la página 20

Drive Type	P _N mot (recommended motor output):										U ₂ Max output voltage	f _z Max output frequency	I _{2N} Rated output current :				f _{sw} switching frequency (Default)	f _{sw} switching frequency (Higher)	Derating factor:				
	Inverter Output (IEC 146 class 1), Continuous service (@ 400 VAC)		Inverter Output (IEC 146 class 2), 150% overload for 60s (@ 400 VAC)		f _{sw} =default; IEC 146 class 1		f _{sw} =default; IEC 146 class 2		f _{sw} =default; IEC 146 class 1				f _{sw} =default; IEC 146 class 2		f _{sw} =default; IEC 146 class 1				f _{sw} =default; IEC 146 class 2		Voltage Factor K _V at 460 VAC *	Temp. Factor K _T for ambient temperature	Switching frequency K _F
	@ U _{LN} =230 VAC ;	f _{sw} =default; IEC 146 class 1	@ U _{LN} =230 VAC ;	f _{sw} =default; IEC 146 class 2	@ U _{LN} =230 VAC ;	f _{sw} =default; IEC 146 class 1	@ U _{LN} =230 VAC ;	f _{sw} =default; IEC 146 class 2	@ U _{LN} =400 VAC ;	f _{sw} =default; IEC 146 class 1			@ U _{LN} =400 VAC ;	f _{sw} =default; IEC 146 class 2	@ U _{LN} =460 VAC ;	f _{sw} =default; IEC 146 class 1			@ U _{LN} =460 VAC ;	f _{sw} =default; IEC 146 class 2			
AVy	kVA	kVA	kW	kW	Hp	Hp	kW	kW	Hp	Hp	V	Hz	A	A	A	A	kHz	kHz	K _V	K _T	K _F		
1007	1.6	1.4	0.37	0.37	0.50	0.50	0.75	0.75	1	0.75		500	2.4	2.2	2.1	1.9	8	16	0.87				
1015	2.7	2.4	0.75	0.75	1	1	1.5	1.5	2	1.5		500	4	3.6	3.5	3.2	8	16	0.87				
1022	3.8	3.4	1.1	1.1	1.5	1.5	2.2	2.2	3	2		500	5.6	5.1	4.9	4.4	8	16	0.87				
1030	5	4.5	1.5	1.5	2	2	3	3	3	3		500	7.5	6.8	6.5	5.9	8	16	0.86				
2040	6.5	5.9	2.2	2.2	3	3	4	4	5	5		500	9.6	8.7	8.3	7.6	8	16	0.86				
2055	8.5	7.7	3	3	4	4	5.5	5.5	7.5	7.5		500	12.6	11.5	11	10	8	16	0.96				
2075	12	10.9	4	4	5	5	7.5	7.5	10	10		500	17.7	16.1	15.4	14	8	16	0.87				
3110	16.8	15.3	5.5	5.5	7.5	7.5	11	11	15	15		500	24.8	22.5	21.6	19.6	8	16	0.93				
3150	22.4	20.3	7.5	7.5	10	10	15	15	20	20		500	33	30	28.7	26	8	16	0.90				
4185	27	24.6	9	9	12.5	12.5	18.5	1.5	25	25		500	39	35.5	33.9	30.9	8	16	0.87				
4220	32	29	11	11	15	15	22	22	30	25		500	47	43	40	36	8	16	0.87				
4300	42	38.2	18.5	15	25	20	30	30	40	30		500	63	58	54	50	8	16	0.87				
4370	55	50	22	18.5	30	25	37	37	50	40		500	79	72	68	62	8	16	0.87				
5450	64	58.3	22	22	30	30	45	45	60	50		200	93	85	81	74	4	8	0.87				
5550	79	72	30	30	40	40	55	55	75	60		200	114	104	99	90	4	8	0.87				
6750	98	89.2	37	37	50	50	75	55	100	75		200	142	129	124	112	4	8	0.87				
7900	128	116.5	55	45	75	60	90	90	125	100		200	185	169	160	146	4	8	0.87				
71100	145	132	55	55	75	75	110	90	150	125		200	210	191	183	166	4	8	0.87				
71320	173	157.5	75	55	100	75	132	110	150	150		200	250	227	217	198	4	8	0.87				
81600	224	204	90	90	100	100	160	160	200	200		200	324	295	282	256	4	-	0.87				
82000	277	252	100	100	125	125	200	200	250	250		200	400	364	384	317	4	-	0.87				



*: Data recorded for operating conditions at an ambient temperature of 40 °C.



*: Dati riportati per condizioni di funzionamento a temperatura ambiente 40°C.



*: Données fournies pour des conditions de fonctionnement sous une température ambiante de 40°C.



*: Die angeführten Daten gelten unter Betriebsbedingungen bei einer Umgebungstemperatur von 40° C.



*: Datos para condiciones de trabajo en una temperatura ambiente de 40°C.

AVy & AVy...-4A Input data

Dati in Ingresso
Caratteristiche d'Entrée

Eingangsdaten
Datos de Entrada

Drive Type	U _{LN} AC Input voltage	AC Input frequency	I _N AC Input current for continuous service, IEC 146 class 1 :						Max short circuit power without line reactor (Z _{min} = 1%)	Overvoltage threshold	Undervoltage threshold	Braking IGBT Unit, Standard internal (with external resistor) MAX braking torque
			- Connection with 3-phase reactor @ 230 V _{AC}	- Connection with 3-phase reactor @ 400 V _{AC}	- Connection with 3-phase reactor @ 460 V _{AC}	- Connection without 3-phase reactor @ 230 V _{AC}	- Connection without 3-phase reactor @ 400 V _{AC}	- Connection without 3-phase reactor @ 460 V _{AC}				
AVy	V	Hz	A	A	A	A	A	A	kVA	V	V	%
1007			1.7	1.9	1.7	3.6	3.9	3.4	160			150
1015			2.9	3.3	2.9	4.4	4.8	4.2	270			150
1022			4	4.5	3.9	6.8	7.4	6.4	380			150
1030			5.5 *	6.2 *	5.4 *	7.9 *	9 *	7.8 *	500			150
2040			7	7.9	7	11	12	10.4	650			120
2055			9.5	10.7	9.3	15.5	16.9	14.7	850			150
2075	3Ph		14 *	15.8 *	13.8 *	21.5 *	24.2 *	21 *	1200			70
3110	480 V _{AC} ± 10%		18.2	20.4	17.8	27.9	30.3	26.4	1700			90
3150	480 V _{AC} ± 10%		25 *	28.2 *	24.5 *	35.4 *	40 *	34.8 *	2250			90
4185	480 V _{AC} - 15% ...	50/60 Hz ± 5%	36	36	31	(1)	(1)	(1)	2700			150 (2)
4220	480 V _{AC} - 15% ...	50/60 Hz ± 5%	39	44	37	(1)	(1)	(1)	3200			150 (2)
4300	230 V _{AC} - 15% ...	50/60 Hz ± 5%	55	62	53	(1)	(1)	(1)	4200			150 (2)
4370	230 V _{AC} - 15% ...	50/60 Hz ± 5%	69	77	66	(1)	(1)	(1)	5500			150 (2)
5450			84	94	82	(1)	(1)	(1)	6400			150 (2)
5550			98	110	96	(1)	(1)	(1)	7900			150 (2)
6750			122	137	120	(1)	(1)	(1)	9800			(3)
7900			158	177	153	(1)	(1)	(1)	12800			(3)
71100			192	216	188	(1)	(1)	(1)	14500	410 V _{DC} (for 230 V _{AC} mains), 800 V _{DC} (for 400 V _{AC} mains), 800 V _{DC} (for 460 V _{AC} mains)	230 V _{DC} (for 230 V _{AC} mains), 380 V _{DC} (for 400 V _{AC} mains), 415 V _{DC} (for 460 V _{AC} mains)	(3)
71320			220	247	214	(1)	(1)	(1)	17300			(3)
81600	400 V _{AC} - 15% ...		-	309	268	(1)	(1)	(1)	22400			(3)
82000	480 V _{AC} + 10%, 3Ph		-	365	318	(1)	(1)	(1)	27700			(3)



*: Use of an external line inductance is recommended for the stated dimensions.

(1): For these types an external inductance is recommended. (2): Optional internal braking unit (with external resistor). (3): External braking unit (optional).



*: Per le taglie indicate si consiglia comunque l'uso di un induttanza di rete.

(1): Per questi modelli è consigliato l'uso dell'induttanza di rete. (2): Unità di frenatura interna opzionale (con resistenza esterna). (3): Unità di frenatura esterna (opzionale).



*: Pour les tailles indiquées, il est conseillé d'utiliser une inductance de réseau.

(1): Pour ces modèles, il est conseillé d'utiliser une inductance de réseau. (2): Unité de freinage interne en option (avec résistance externe). (3): Unité de freinage extérieure (option).



*: Für die angeführten Größen wird in jedem Fall die Verwendung einer Netzdrössel empfohlen.

(1): Für diese Modelle wird die Verwendung einer Netzdrössel empfohlen. (2): Optionale interne Bremsenheit (mit externem Widerstand). (3): Externe Bremsenheit (optional).



*: Se recomienda el uso de inductancias de red para las dimensiones establecidas.

(1): Se recomienda una inductancia de red para este tipo. (2): Unidad de frenado interna opcional (con resistencia externa). (3): Unidad de frenado externo (opcional).

Inverter Selection

AVy...-C/CP Output data

Dati in Uscita
Caractéristiques de Sortie

Ausgangsdaten
Datos de Salida

Drive Type	Inverter Output (IEC 146 class 1), Continuous service (@ 400 V _{AC})		P _N mot (recommended motor output):				U ₂ Max output voltage	f ₂ Max output frequency	I _{2N} Rated output current :				f _{sw} switching frequency (Default)	f _{sw} switching frequency (Higher)	Derating factor : Temp. Factor K _T for ambient temperature
	Inverter Output (IEC 146 class 2), 150% overload for 60s (@ 400 V _{AC})		@ U _{LN} =400 V _{AC} ; f _{sw} = default; IEC 146 class 1	@ U _{LN} =400 V _{AC} ; f _{sw} = default; IEC 146 class 2	@ U _{LN} =460 V _{AC} ; f _{sw} = default; IEC 146 class 1	@ U _{LN} =460 V _{AC} ; f _{sw} = default; IEC 146 class 2			@ U _{LN} =400 V _{AC} ; f _{sw} = default; IEC 146 class 1	@ U _{LN} =400 V _{AC} ; f _{sw} = default; IEC 146 class 2	@ U _{LN} =460 V _{AC} ; f _{sw} = default; IEC 146 class 1	@ U _{LN} =460 V _{AC} ; f _{sw} = default; IEC 146 class 2			
	kVA	kVA	kW	kW	Hp	Hp	V	Hz	A	A	A	A	kHz	kHz	K _T
92500-C	335	305	250	250	350	300	0.98 x U _{LN} (AC Input voltage)	200	485	441	422	384	2	no setting	0.8 @ 50°C (122°F)
93150-CP	400	363	315	250	450	450		200	580	527	566	515	2	no setting	

 AVy93150-CP overload capacity: 113 % for 60s (@400Vac),
124 % for 60s (460Vac)

 AVy93150-CP capacité de surcharge : 113 % pendant 60s (@400Vca)
124 % pendant 60s (460Vca)

 AVy93150-CP capacità di sovraccarico: 113 % per 60s (@400Vac)
124 % per 60s (460Vac)

 AVy93150-CP Überlastkapazität: 113 % für 60 s (bei 400Vac)
124 % für 60 s (460Vac)

 AVy93150-CP capacidad de sobrecarga: 113 % para 60s (@400Vac)
124 % para 60s (400Vac)

AVy...-C/CP Input data

Dati in Ingresso
Caractéristiques d'Entrée

Eingangsdaten
Datos de Entrada

Drive Type	U _{LN} AC Input voltage	Voltage balance	AC Input frequency	I _N AC Input current @ 400 V _{AC}	I _N AC Input current @ 460 V _{AC}	Interrupt short circuit current
	V	%	Hz	A	A	kA
92500-C	400 V _{AC} -15% ...	3	50/60 Hz ±5%	520	425	18
93150-CP	480 V _{AC} +10%, 3Ph	3	50/60 Hz ±5%	600	560	30

 Devices may be used on a circuit designed to supply only symmetrical
amps in milliseconds as shown in the table (maximum 460 volts).

 Die Geräte können in einem Netz verwendet werden, das eine symmetrische
Kurzschlussleitung gleich oder niedriger laut Tabelle liefern kann (bei
maximal 460 Volt).

 Gli apparecchi possono essere utilizzate su un circuito in grado di fornire
unicamente gli ampere simmetrici in millisecondi indicati in tabella (massimo
460 Volt).

 Los equipos se pueden utilizar en un circuito que entregue únicamente los
amperios de forma simétrica en los milisegundos indicados en la tabla
(máximo 460 Voltios).

 Les appareils peuvent être utilisés sur un circuit à même de fournir uniquement
les ampères symétriques en millisecondes indiqués dans le tableau (maximum
460 Volts).

AVy...-5 Output data

Dati in Uscita
Caractéristiques de Sortie

Ausgangsdaten
Datos de Salida

Drive Type	Inverter Output (IEC 146 class 1), Continuous service (@ 575 V _{AC})		Inverter Output (IEC 146 class 2), 150% overload for 60s (@ 575 V _{AC})		P _N mot (recommended motor output):		U ₂ Max output voltage	f _z Max output frequency	I _{2N} Rated output current :		f _{sw} switching frequency (Default)	f _{sw} switching frequency (Higher)	Derating factor :	
	@ U _{LN} = 575 V _{AC} ;	f _{sw} = default; IEC 146 class 1	@ U _{LN} = 575 V _{AC} ;	f _{sw} = default; IEC 146 class 2	@ U _{LN} = 575 V _{AC} ;	f _{sw} = default; IEC 146 class 1			@ U _{LN} = 575 V _{AC} ;	f _{sw} = default; IEC 146 class 2			Temp. Factor K _T for ambient temperature	Switching frequency K _F (for higher f _{sw})
AVy	kVA	kVA	Hp	Hp	V	Hz	A	A	kHz	kHz	K _T	K _F		
2002	3.8	3.4	2	2		400	3.8	3.5	8	16		0.7		
2003	4.5	4.1	3	3		400	4.5	4.1	8	16		0.7		
2005	7.0	6.3	5	5		400	7.0	6.3	8	16		0.7		
3007	10,8	9.8	7.5	7.5		400	10.8	9.8	8	16		0.7		
3010	13.7	12.5	10	10		400	13.7	12.5	8	16		0.7		
3015	18.6	16.9	15	15		400	18.6	16.9	8	16		0.7		
3020	24.1	21.9	20	20		200	24.1	21.9	4	8		0.87		
4025	30	27	25	25		200	30	27	4	8		0.8		
4030	36	33	30	30		200	36	33	4	8		0.8		
4040	46	42	40	40		200	46	42	4	8		0.8		
5050	58	53	50	50	0.98 x U _{LN} (AC Input voltage)	200	58	53	4	8		0.8		
5060	69	63	60	60		200	69	63	4	8		0.8		
5075	86	78	75	75		200	86	78	4	8		0.64		
6100	109	99	100	100		200	109	99	4	4		-		
7125	136	125	125	125		200	137	125	4	4		-		
7150	157	143	150	150		200	158	144	2	4		0.87		
8200	210	191	200	200		200	211	192	2	2		-		





Standard Versions

AVy...-5 Input data

Dati in Ingresso
Caratteristiche d'Entrée

Eingangsdaten
Datos de Entrada

Drive Type	U _{LN} AC Input voltage	AC Input frequency	I _N AC Input current for continuous service, IEC 146 class 1 :		Max short circuit power without line reactor (Zmin=1%)	Overvoltage threshold	Undervoltage threshold	Braking IGBT Unit, MAX braking torque
			- Connection with 3-phase reactor @ 575 V _{AC}	- Connection without 3-phase reactor @ 575 V _{AC}				
AVy	V	Hz	A	A	kVA	V	V	%
2002			3.8	5.3	380			150 (1)
2003			4.7	6.1	450			150 (1)
2005			7.4	9.9	700			150 (1)
3007			11.7	17	1080			150 (1)
3010			15	20.7	1370			150 (1)
3015			19.8	27.6	1860			150 (1)
3020			25.9	33.9	2410			150 (1)
4025	575 V _{AC} +10% ... -10% , 3Ph	50/60 Hz ±5%	31	(4)	3000	1000 V _{DC}	565 V _{DC} (for 575 V _{AC} mains)	150 (2)
4030			35	(4)	3600			150 (2)
4040			46	(4)	4600			150 (2)
5050			60	(4)	5800			150 (2)
5060			68	(4)	6900			150 (2)
5075			85	(4)	8600			150 (2)
6100			114	(4)	10900			(3)
7125			146	(4)	13700			(3)
7150			163	(4)	15700			(3)
8200			220	(4)	21000			(3)

 (1): Standard internal (with external resistor). (2): Optional internal braking unit (with external resistor). (3): External braking unit (optional). (4): DC choke integrated
 (1): Interna standard (con resistenza esterna). (2): Unità di frenatura interna opzionale (con resistenza esterna). (3): Unità di frenatura esterna (opzionale). (4): Induttanza su DC link integrata
 (1): Standard en interne (avec résistance externe). (2): Unité de freinage interne ne option (avec résistance externe). (3): Unité de freinage extérieure (option). (4): Self DC intégrée
 (1): Standard eingebaut (mit externem Bremswiderstand). (2): Eingebaute Bremsseinheit optional (mit externem Bremswiderstand). (3): Externe Bremsseinheit (optional). (4): Eingebaute Zwischenkreis-Drosseln
 (1): Interna estándar (con resistencia externa). (2): Unidad de frenado interno opcional (con resistencia externa). (3): Unidad de frenado exterior (opcional). (4): Bobina CC integrada

Standard Versions

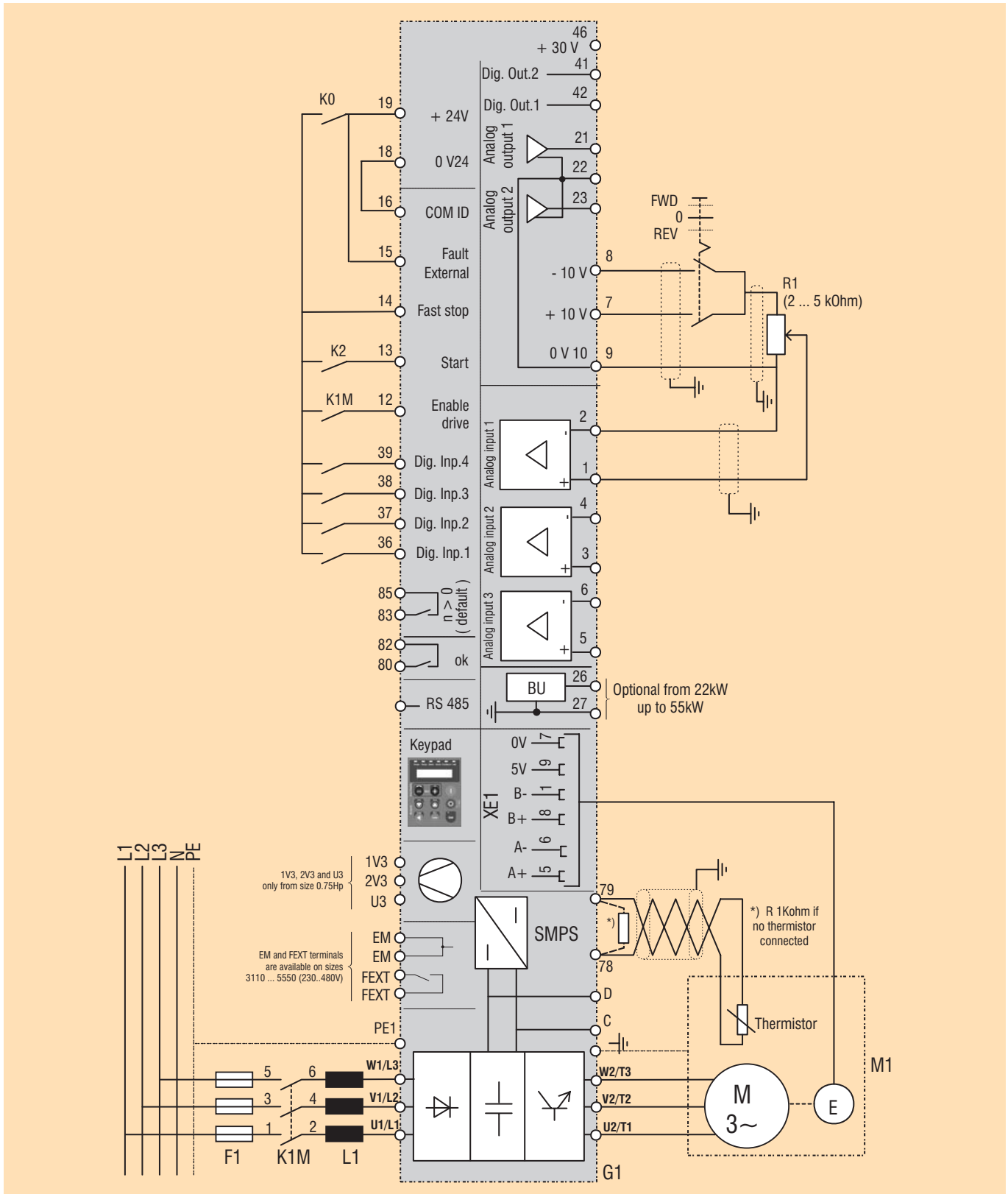

The connection diagram describes a typical inverter connection arrangement, set up to handle PNP logic "Terminal box commands". Refer to the instruction manual for additional detailed data.

Note: the connection diagram for the digital I/O applies to the AVy range.



Lo schema di collegamento indica una connessione tipica dell'inverter, predisposto per "Comandi da morsetteria" in logica PNP.

Ulteriori informazioni dettagliate, sono disponibili nel relativo manuale d'istruzione. Nota: lo schema di collegamento degli I/O digitali è relativo alla linea "AVy".



Le schéma de connexion indique une connexion typique du variateur, prévu pour "Commandes par bornes" en logique PNP.

Pour de plus amples informations voir la notice d'instruction correspondante.

Note : le schéma de raccordement des E/S digitales concerne la ligne "AVy"



Der Anschlussplan zeigt einen typischen Frequenzumrichteranschluss, der für "Befehle über Klemmleiste" in PNP-Logik bestimmt ist.

Nähere Informationen sind dem entsprechenden Handbuch zu entnehmen.

Hinweis: Der Anschlussplan für die Digital-I/O bezieht sich auf die Serie "AVy".



El esquema de conexión describe un convertidor de frecuencia con una conexión típica, instalada para manejar en lógica PNP "Mandos de la Caja de Terminales".

Utilice el manual de instrucciones para información detallada adicional.

Nota: el esquema de conexiones de las E/S digitales es en relación con la línea "AVy".

Technical Specifications

Specifiche Tecniche
Spécifications Techniques

Technische Spezifikationen
Especificaciones Técnicas

Dimensions and Weights

AVy1... , AVy2... , AVy3...

Dimensioni e Pes
Dimensions et Poids
Abmessungen und Gewichte
Dimensiones y Pesos

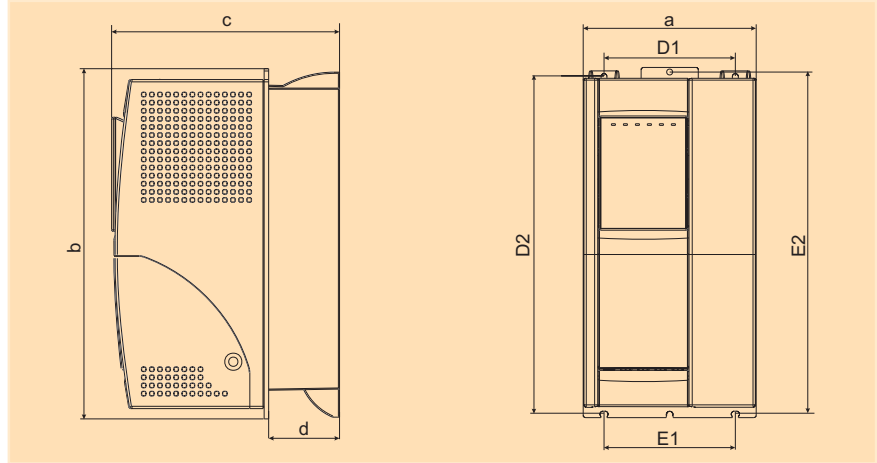

Mounting Method

Metodo di Montaggio
Mode de Montage
Montageart
Metodos de Montaje

- (E): Assembly with external heatsink
 Montaggio con dissipatore esterno
 Montage avec dissipateur extérieur
 Montage mit externem Kühlkörper
 Montaje con disipador externo
- (D): Wall assembly
 Montaggio a muro
 Montage au mur
 Wandmontage
 Montaje a la pared

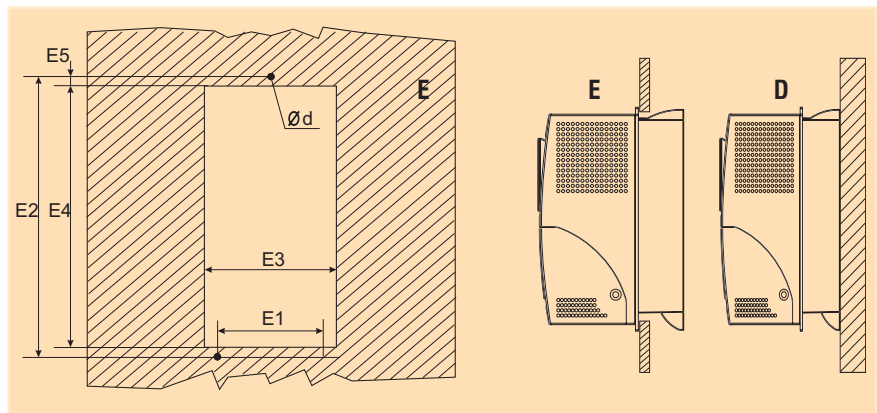

Dimensions mm [inch]	AVy & AVy...-4A									AVy...-5 (575V)						
	1007	1015	1022	1030	2040	2055	2075	3110	3150	2002	2003	2005	3007	3010	3015	3020
a	105.5 [4.1]	105.5 [4.1]	105.5 [4.1]	105.5 [4.1]	151.5 [5.9]	151.5 [5.9]	151.5 [5.9]	208 [8.2]	208 [8.2]	151.5 [5.9]	151.5 [5.9]	151.5 [5.9]	208 [8.2]	208 [8.2]	208 [8.2]	208 [8.2]
b	306.5 [12.0]	306.5 [12.0]	306.5 [12.0]	306.5 [12.0]	306.5 [12.0]	306.5 [12.0]	306.5 [12.0]	323 [12.7]	323 [12.7]	306.5 [12.0]	306.5 [12.0]	306.5 [12.0]	323 [12.7]	323 [12.7]	323 [12.7]	323 [12.7]
c	199.5 [7.8]	199.5 [7.8]	199.5 [7.8]	199.5 [7.8]	199.5 [7.8]	199.5 [7.8]	199.5 [7.8]	240 [9.5]	240 [9.5]	199.5 [7.8]	199.5 [7.8]	199.5 [7.8]	240 [9.5]	240 [9.5]	240 [9.5]	240 [9.5]
d	62 [2.4]	62 [2.4]	62 [2.4]	62 [2.4]	62 [2.4]	62 [2.4]	62 [2.4]	84 [3.3]	84 [3.3]	62 [2.4]	62 [2.4]	62 [2.4]	84 [3.3]	84 [3.3]	84 [3.3]	84 [3.3]
D1	69 [2.7]	69 [2.7]	69 [2.7]	69 [2.7]	115 [4.5]	115 [4.5]	115 [4.5]	168 [6.6]	168 [6.6]	115 [4.5]	115 [4.5]	115 [4.5]	168 [6.6]	168 [6.6]	168 [6.6]	168 [6.6]
D2	296.5 [11.6]	296.5 [11.6]	296.5 [11.6]	296.5 [11.6]	296.5 [11.6]	296.5 [11.6]	296.5 [11.6]	310.5 [12.2]	310.5 [12.2]	296.5 [11.6]	296.5 [11.6]	296.5 [11.6]	310.5 [12.2]	310.5 [12.2]	310.5 [12.2]	310.5 [12.2]
E1	69 [2.7]	69 [2.7]	69 [2.7]	69 [2.7]	115 [4.5]	115 [4.5]	115 [4.5]	164 [6.5]	164 [6.5]	115 [4.5]	115 [4.5]	115 [4.5]	164 [6.5]	164 [6.5]	164 [6.5]	164 [6.5]
E2	299.5 [11.7]	299.5 [11.7]	299.5 [11.7]	299.5 [11.7]	299.5 [11.7]	299.5 [11.7]	299.5 [11.7]	315 [12.4]	315 [12.4]	299.5 [11.7]	299.5 [11.7]	299.5 [11.7]	315 [12.4]	315 [12.4]	315 [12.4]	315 [12.4]
E3	99.5 [3.9]	99.5 [3.9]	99.5 [3.9]	99.5 [3.9]	145.5 [5.7]	145.5 [5.7]	145.5 [5.7]	199 [7.8]	199 [7.8]	145.5 [5.7]	145.5 [5.7]	145.5 [5.7]	199 [7.8]	199 [7.8]	199 [7.8]	199 [7.8]
E4	284 [11.2]	284 [11.2]	284 [11.2]	284 [11.2]	284 [11.2]	284 [11.2]	284 [11.2]	299.5 [11.8]	299.5 [11.8]	284 [11.2]	284 [11.2]	284 [11.2]	299.5 [11.8]	299.5 [11.8]	299.5 [11.8]	299.5 [11.8]
E5	9 [0.35]	9 [0.35]	9 [0.35]	9 [0.35]	9 [0.35]	9 [0.35]	9 [0.35]	9 [0.35]	9 [0.35]	9 [0.35]	9 [0.35]	9 [0.35]	9 [0.35]	9 [0.35]	9 [0.35]	9 [0.35]
Ø d	M5	M5	M5	M5	M5	M5	M5	M5	M5	M5	M5	M5	M5	M5	M5	M5
Weight kg [lbs]	3.5 [7.7]	3.6 [7.9]	3.7 [8.1]	3.7 [8.1]	4.95 [10.9]	4.95 [10.9]	4.95 [10.9]	8.6 [19]	8.6 [19]	4.6 [10.1]	4.6 [10.1]	4.8 [10.6]	8.2 [18]	8.2 [18]	8.8 [19.4]	8.8 [19.4]

Dimensions and Weights

AVy4... , AVy5... , AVy6... ,
AVy7... , AVy8...

Dimensioni e Pesi
Dimensions et Poids
Abmessungen und Gewichte
Dimensiones y Pesos

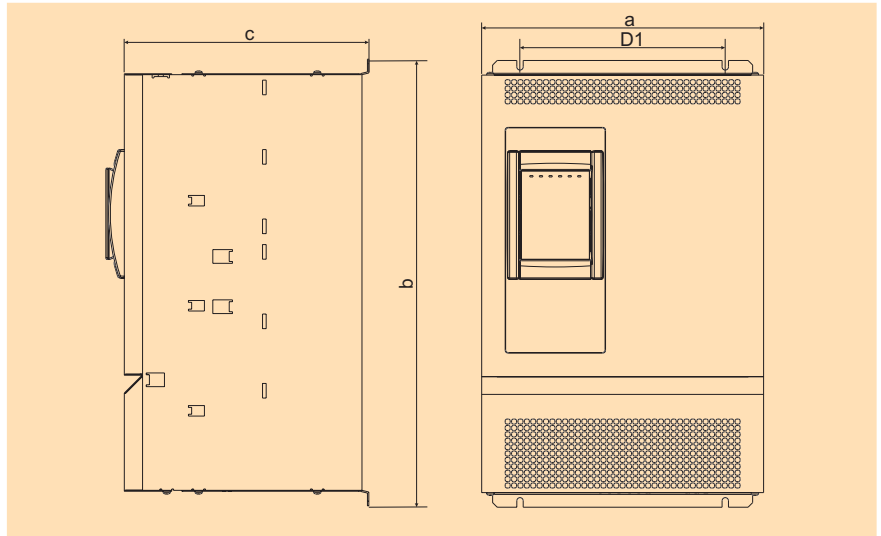

Mounting Method

Metodo di Montaggio
Mode de Montage
Montageart
Metodos de Montaje

- (D): Wall mounting
 Montaggio a muro
 Montage au mur
 Wandmontage
 Montaje a la pared

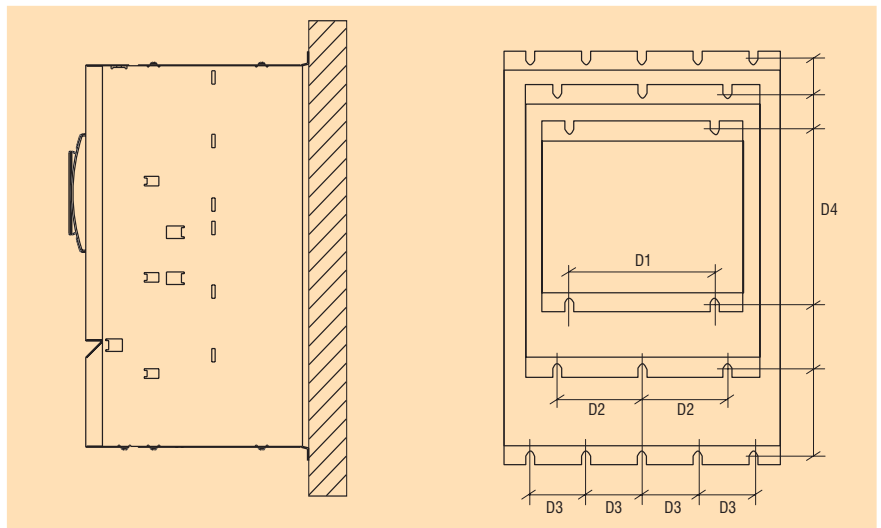

Standard Versions

Dimensions	AVy & AVy...-4A										AVy...-5 (575V)									
	4185 4220	4300	4370	5450 5550	6750	7900	7110	71320	81600	82000	4025	4030	4040	5050	5060	5075	6100	7125	7150	8200
a	309 [12.1]	309 [12.1]	309 [12.1]	376 [14.7]	509 [20]	509 [20]	509 [20]	509 [20]	509 [20]	509 [20]	350 [13.8]	350 [13.8]	350 [13.8]	418 [16.4]	418 [16.4]	418 [16.4]	509 [20]	509 [20]	509 [20]	509 [20]
b	489 [19.2]	489 [19.2]	489 [19.2]	564 [22.2]	741 [29.2]	909 [35.8]	909 [35.8]	909 [35.8]	965 [38]	965 [38]	569 [22.4]	569 [22.4]	569 [22.4]	605 [23.8]	605 [23.8]	605 [23.8]	921 [36.2]	1113 [43.8]	1113 [43.8]	1183 [46.6]
c	268 [10.5]	308 [12.1]	308 [12.1]	308 [12.1]	297.5 [11.7]	297.5 [11.7]	297.5 [11.7]	297.5 [11.7]	442 [17.4]	442 [17.4]	268 [10.5]	268 [10.5]	320 [12.6]	320 [12.6]	320 [12.6]	320 [12.6]	297.5 [11.7]	297.5 [11.7]	297.5 [11.7]	297.5 [11.7]
D1	225 [8.8]	225 [8.8]	225 [8.8]	-	-	-	-	-	-	-	-	-	-	-	-	-	-	-	-	-
D2	-	-	-	150 [15.9]	-	-	-	-	-	-	150 [15.9]	150 [15.9]	150 [15.9]	150 [15.9]	150 [15.9]	150 [15.9]	-	-	-	-
D3	-	-	-	-	100 [3.9]	100 [3.9]	100 [3.9]	100 [3.9]	100 [3.9]	100 [3.9]	-	-	-	-	-	-	100 [3.9]	100 [3.9]	100 [3.9]	100 [3.9]
D4	475 [18.7]	475 [18.7]	475 [18.7]	550 [21.6]	725 [28.5]	891 [35]	891 [35]	891 [35]	947 [37.3]	947 [37.3]	555 [21.2]	555 [21.2]	555 [21.2]	590 [23.2]	590 [23.2]	590 [23.2]	903 [35.5]	1095 [43.1]	1095 [43.1]	1095 [43.1]
Ø d	M6	M6	M6	M6	M6	M6	M6	M6	M6	M6	M6	M6	M6	M6	M6	M6	M6	M6	M6	M6
Weight kg [lbs]	18 [39.6]	22 [48.5]	22.2 [48.9]	34 [74.9]	59 [130]	75.4 [166.1]	80.2 [176.7]	86.5 [190.6]	109 [240.3]	109 [240.3]	28.6	28.6	31.6 [69.5]	47 [103.6]	47 [103.6]	47 [103.6]	83 [183]	118 [260.1]	118 [260.1]	131 [288.8]

Dimensions and Weights

AVy...-C, AVy...-CP

Dimensioni e Pesi
Dimensions et Poids
Abmessungen und Gewichte
Dimensiones y Pesos

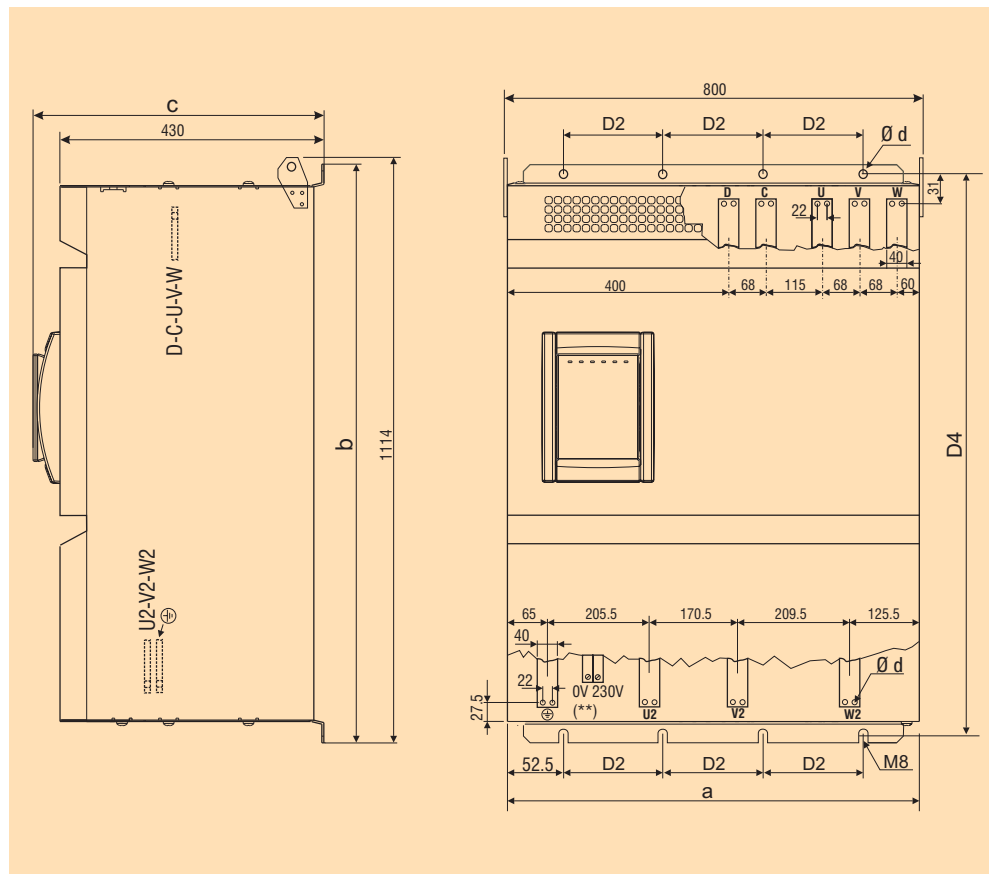

- (D):
-  Wall mounting
 -  Montaggio a muro
 -  Montage au mur
 -  Wandmontage
 -  Montaje a la pared

Type	Dimensions mm [inch]								Weight kg [lbs]
	a	b	c	D1	D2	D3	D4	Ø d	
AVy92500-C	776 [30.6]	1091 [43]	450 [17.7]	-	225 [8.9]	-	1075 [42.3]	M8	155 [341.7]
AVy93150-CP	776 [30.6]	1091 [43]	450 [17.7]	-	225 [8.9]	-	1075 [42.3]	M8	155 [341.7]

Inverter Dissipation and Fan Flow

Dissipazione Inverter e Portata Ventilatori
Dissipation du Variateur et Débit des Ventilateurs

Frequenzumrichter-Verlustleistung und Lüfterleistung
Disipación del Convertidor de Frecuencia y Ventilación forzada

Drive Type	P _V Heat dissipation (f _{sw} =default; I ₂ =I _{2N}):				Airflow of fan		Minimum cooling opening	
	@U _{LN} =230 V _{AC}	@U _{LN} =400 V _{AC}	@U _{LN} =460 V _{AC}	@U _{LN} =575 V _{AC}	Internal fan	Heatsink fans	Control section	Heatsink
AVy ... -4 / -4A (230V...480V)	W	W	W	W	m³ / h	m³ / h	cm² (sq.inch)	cm² (sq.inch)
1007	40	48.2	45	-	11	-	31 (4.8)	36 (5.6)
1015	70	77.5	72	-	11	30	31 (4.8)	36 (5.6)
1022	92	104	96.3	-	11	30	31 (4.8)	36 (5.6)
1030	121	138.3	126.7	-	11	30	31 (4.8)	36 (5.6)
2040	160	179.6	164.1	-	11	2x30	31 (4.8)	72 (11.1)
2055	184	230	215.6	-	11	2x30	31 (4.8)	72 (11.1)
2075	264	330	300.8	-	11	2x30	31 (4.8)	72 (11.1)
3110	304	380	340	-	30	2x79	36 (5.6)	128 (19.8)
3150	416	520	468	-	30	2x79	36 (5.6)	128 (19.8)
4185	448	546	490	-	-	80	-	2x150 (2x23.5)
4220	526	658	582	-	-	80	-	2x150 (2x23.5)
4300	691	864	780	-	-	170	-	2x200 (2x31)
4370	880	1100	1000	-	-	170	-	2x200 (2x31)
5450	1000	1250	1100	-	-	340	-	2x370 (2x57.35)
5550	1264	1580	1390	-	-	340	-	2x370 (2x57.35)
6750	1560	1950	1750	-	-	650	-	2x620 (2x96.1)
7900	1952	2440	2200	-	-	975	-	2x620 (2x96.1)
71100	2280	2850	2560	-	-	975	-	2x620 (2x96.1)
71320	2720	3400	3050	-	-	975	-	2x620 (2x96.1)
81600	-	4400	3950	-	-	1820	-	2x1600 (2x48)
82000	-	5400	4700	-	-	2000	-	2x1600 (2x48)
AVy ... -C/CP	W	W	W	W	m³ / h	m³ / h	cm² (sq.inch)	cm² (sq.inch)
92500-C	-	6400	5700	-	-	1710	-	2x1600 (2x48)
93150-CP	-	8000	7900	-	-	1710	-	2x1600 (2x48)
AVy ... -5 (575V)	W	W	W	W	m³ / h	m³ / h	cm² (sq.inch)	cm² (sq.inch)
2002	-	-	-	75	11	30	31 (4.8)	72 (11.1)
2003	-	-	-	80	11	30	31 (4.8)	72 (11.1)
2005	-	-	-	128	11	2x30	31 (4.8)	72 (11.1)
3007	-	-	-	215	30	2x79	36 (5.6)	128 (19.8)
3010	-	-	-	266	30	2x79	36 (5.6)	128 (19.8)
3015	-	-	-	338	30	2x79	36 (5.6)	2x150 (2x23.5)
3020	-	-	-	453	30	2x79	36 (5.6)	2x200 (2x31)
4025	-	-	-	515	-	2x80	-	2x200 (2x31)
4030	-	-	-	620	-	2x80	-	2x370 (2x57.35)
4040	-	-	-	810	-	170	-	2x370 (2x57.35)
5050	-	-	-	1070	-	340	-	2x370 (2x57.35)
5060	-	-	-	1155	-	340	-	2x370 (2x57.35)
5075	-	-	-	1480	-	340	-	2x370 (2x57.35)
6100	-	-	-	2150	-	650	-	2x620 (2x96.1)
7125	-	-	-	2760	-	975	-	2x620 (2x96.1)
7150	-	-	-	2760	-	975	-	2x620 (2x96.1)
8200	-	-	-	3250	-	975	-	2x620 (2x96.1)

General Features

Introduction

The **AVy ARTDrive** inverters in cabinet configuration not only offer beneficial technological solutions, but also provide considerable savings in terms of space and mounting and commissioning time.

Available as standard for ratings from 250kW (300Hp) to 630kW (700Hp), **AVy** inverters integrate both power and auxiliary electromechanical devices, as well as the whole range of accessories for ensuring the correct use of an AC control system.

They offer the ideal configuration to ensure the motor's immediate start-up and easy control for high-power systems.

The power bridge structures can also be supplied as stand-alone IP00 versions, enabling panel builders and system integrators to easily meet the numerous requests for customised systems.

Introduzione

Gli inverter **ARTDrive "AVy"** in configurazione in quadro elettrico, oltre ad offrire vantaggiose soluzioni tecnologiche, consentono un notevole risparmio in termini di tempi di assemblaggio, di messa in servizio e di spazi.

Disponibili come standard per potenze da 250kW (300Hp) fino a 630kW (700Hp), gli inverter **AVy** integrano sia dispositivi elettromeccanici di potenza che ausiliari, nonché tutta la serie di accessori atti al corretto impiego di un sistema di regolazione in c.a. Una configurazione ideale per un immediato "start up" del motore ed un facile controllo per sistemi di grosse potenze.

Le strutture dei ponti di potenza, possono inoltre essere fornite in versioni IP00 "stand alone" consentendo a quadristi e system integrator di soddisfare facilmente le molteplici richieste di sistemi personalizzati.

Introduction

Les variateurs **ARTDrive "AVy"** configurés dans une armoire électrique, en plus d'offrir des solutions technologiques avantageuses, permettent un gain important en matière de temps d'assemblage, de mise en service et d'espaces.

Disponible en standard pour les puissances de 250kW (300Hp) jusqu'à 630kW (700Hp), les variateurs **AVy** intègrent tant les dispositifs électromécaniques de puissance qu'auxiliaires, ainsi que toute la série d'accessoires permettant une bonne utilisation d'un système de régulation en c.a. Une configuration idéale pour un "start up" immédiat du moteur et un contrôle aisé pour les systèmes de grandes puissances.

Les structures des ponts de puissance, peuvent également être fournies en versions IP00 "stand alone" permettant ainsi aux installateurs d'armoires et aux systèmes intégrateurs de répondre facilement aux multiples demandes de systèmes personnalisés.



Einleitung

Die Frequenzrichter **ARTDrive "AVy"** in elektrischer Schalttafelkonfiguration bieten vorteilhafte technologische Lösungen und ermöglichen erhebliche Einsparungen in Sachen Montagezeit, Inbetriebsetzung und Raumbedarf.

Die Frequenzrichter **AVy** sind als Standard für Leistungen von 250 kW (300 Hp) bis 630 kW (700 Hp) erhältlich. Sie verfügen über elektromechanische Leistungs- und Hilfseinrichtungen sowie über eine Reihe von Zubehörteilen, die dem korrekten Einsatz eines Drehstrom-Regelungssystems dienen.

Eine ideale Konfiguration für den unmittelbaren Anschluss des Motors und einfache Steuerung für Systeme mit hohen Leistungen.

Die Komponenten der Leistungsbrücken können außerdem in IP00 „Stand alone“-Ausführungen geliefert werden und ermöglichen es Schallwärmern und Systemintegratoren, den verschiedensten Ansprüchen anwendungsbezogener Systeme gerecht zu werden.

Introducción

Los inversores **ARTDrive "AVy"** en configuración de cuadro eléctrico, además de ofrecer ventajosas soluciones tecnológicas, consiguen un notable ahorro en términos de tiempo de montaje, de puesta en servicio y de espacio.

Disponibles como estándar para potencias de 250kW (300CV) hasta 630kW (700CV), los inversores **AVy** integran tanto dispositivos electromecánicos de potencia como auxiliares, siempre que toda la serie de accesorios conectados a la corriente dispongan de un sistema de regulación en c.a.

Una configuración ideal para un "arranque" inmediato del motor y un fácil control para sistemas de gran potencia.

Las estructuras de los puentes de potencia, también pueden suministrarse en versiones IP00 "stand alone" permitiendo a los instaladores de cuadros e integradores de sistemas satisfacer de forma fácil los múltiples requisitos de los sistemas personalizados.

Identification Code

Codice di Identificazione
Code d'Identification
Identifikationscode
Siglas Identificación Producto



AVy	ARTDrive AC Inverter, 3 phase input voltage	ARTDrive Inverter CA, alimentazione trifase	ARTDrive Variateur CA, alimentation triphasée	ARTDrive Drehstrom-Frequenzrichter, dreiphasige	ARTDrive Inverter CA, alimentación trifásica
①	Enclosure dimension identification	Identificazione della dimensione	Taille du boîtier	Versorgung Baugröße	Identificación de las dimensiones
②	AVy : I.e.: 400 = 400kW Inverter rated output power	AVy : Es.: 400 = 400kW Potenza nominale in uscita	AVy : Es: 400 = 400kW Puissance nominale de sortie	AVy : z.B.: 400 = 400kW Ausgangsnennleistung	AVy : Es.: 400 = 400kW Potencia nominal de salida
③	K = Programming keypad KBS	K = Tastierino di programmazione KBS	K = Clavier de programmation KBS	K = Programmierungs-Bedieneinheit KBS	K = Teclado de programación KBS
④	X = without integrated braking circuit	X = senza unità di frenatura interna	X = sans unité de freinage interne	X = ohne Bremskreis	X = suministro sin unidad de frenado integrada
⑤	X = Standard software	X = Software standard	X = Logiciel standard	X = Standardsoftware	X = Software estándar
⑥	[IP00] = open frame [IP23] = housing IP23 [IP54] = housing IP54	[IP00] = a giorno [IP23] = alloggiamento IP23 [IP54] = alloggiamento IP54	[IP00] = à jour [IP23] = boîtier IP23 [IP54] = boîtier IP54	[IP00] = Freiluftausführung [IP23] = Gehäuse IP23 [IP54] = Gehäuse IP54	[IP00] = por día [IP23] = almacenamiento IP23 [IP54] = almacenamiento IP54

 General Features

AVy (cabinet and open frame) range

- 3-phase power supply: 400Vac -15% ... 480Vac +10%, 50/60Hz
- Motor ratings
 - 250kW (300Hp)
 - 315kW (450Hp)
 - 400kW (500Hp)
 - 500kW (600Hp)
 - 630kW (700Hp)
- Standard version with default power supply setting at 400Vac, 50Hz

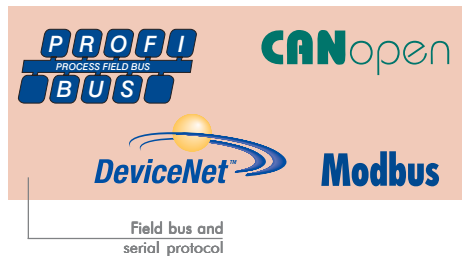

Specifications

- Vibration: based on standard IEC68-2-6
- Interference immunity: based on standard IEC801 sections 2, 3 and 4

Standards and Marks

CE: complies with the EEC directive concerning low voltage equipment.
EMC: complies with the EEC directive - EN 61800-3:2004 concerning electromagnetic compatibility with the use of optional filters.



Control modes

- Closed Loop Flux Vector control:
 - sinusoidal encoder (speed accuracy: 0.01%)
 - digital encoder (speed accuracy: 0.02%)
- Flux Vector control without encoder feedback (sensorless) (speed accuracy: 0.1% above 100rpm, 0.2% below 100rpm)
- V/f scalar control (speed accuracy varies with motor slip)

Main control and regulation functions

- Offline self-tuning: for speed-current-flux loops and identifying motor data (possible with motor idle or rotating)
- Online self-tuning: compensation for motor parameters according to temperature variations
- Overload capacity compliant with IEC 146 Class 1 and Class 2, see table on page 33
- Electronic thermal protection for motor and drive
- Multi-speed function (with 7 programmable speeds)
- 5 independent, programmable ramps (linear and S-curve)
- Motor potentiometer function
- Motor "auto-capture" function
- Droop function
- Dual motor management
- PID function block
- Mains loss detection with controlled stop and/or power optimisation
- Virtual or remote I/O management

Standard supply configuration

- LCD programming keypad or LED diagnostics module
- Integrated RS485 serial connection (ModBus RTU protocol)
- Standard inputs/outputs:
 - 3 programmable differential analogue inputs (voltage/current)
 - 2 programmable analogue outputs
 - 8 digital inputs: 4 non-programmable + 4 programmable
 - 2 programmable digital outputs
 - 2 programmable relay outputs
- Integrated encoder input: sinusoidal 1Vpp (+5V) and digital TTL (+5V)
- EasyDrive, an advanced configuration software application for PC, including
 - programming inverter function blocks in a graphical environment
 - user file archiving
 - guided programming procedure for commissioning using a Wizard function
 - graphic display of variables via a "Trend recorder" oscilloscope function
- Interfacing with fieldbus: ProfiBus, CANopen and DeviceNet (with optional card)
- Automatic line circuit breaker (cabinet versions only)
- Fast-acting mains fuses (cabinet versions only)
- Rectifier bridge and inverter bridge (separate or integrated depending on the rating)
- Electromechanical auxiliary device (cabinet versions only)
- Line inductor (cabinet versions only)
- Control panel on door with (cabinet versions only):
 - Programming keypad
 - Start/Stop keys
 - Reset button
 - Emergency button
 - Mains connection and alarm indicator

Accessories (optional)

- Dedicated EMC filters (compliant with EEC Directive - EN61800-3)
- Braking resistors (standardised for the whole range)
- Output inductors (standardised for the whole range)
- Dynamic braking unit
- Customisable control panel on door

Environmental conditions

Housing: IP23 in cabinet as standard
 IP54 in cabinet on request (with cooling filters and/or conditioners)
 IP00 for inverter bridge supplied separately

Operating temperature: from 0°C to 40 °C, from + 40 °C to +50 °C with derating.

Storage temperature:

- 250kW (300Hp) and 315kW (450Hp): -20°C...+55°C
- from 400kW (500Hp) to 630kW (700Hp): -25°C...+70°C

from 5% to 85%, relative humidity (without condensation) or formation of ice (Class 3K3 under EN50178)

Humidity:

Altitude: up to 2000 metres above sea level. Above 1000 metres, that the current is reduced by 1.2% for each additional 100 metres in altitude.

Cabinet & Open Frame Versions

General Features

 Caratteristiche Generali

Linea "AVy (Armadio e a giorno)"

- Alimentazione trifase:
400Vac -15% ... 480Vac +10%, 50/60Hz
- Potenze motore:
 - 250kW (300Hp)
 - 315kW (450Hp)
 - 400kW (500Hp)
 - 500kW (600Hp)
 - 630kW (700Hp)
- Versione standard con impostazione di default per alimentazioni a 400Vac, 50Hz

Modalità di controllo

- Controllo Vettoriale di Flusso ad anello chiuso:
 - encoder sinusoidale (precisione di velocità: 0,01%)
 - encoder digitale (precisione di velocità: 0,02%)
- Controllo Vettoriale di Flusso senza retroazione da encoder (Sensorless) (precisione di velocità: 0,1% sopra i 100rpm, 0,2% sotto i 100rpm)
- Controllo scalare V/f (precisione di velocità in funzione dello scorrimento del motore)

Funzioni di controllo e regolazione principali

- Frequenza di uscita: 200Hz con e senza retroazione da encoder
- Autotartatura off-line: dei regolatori di velocità-corrente-flusso ed identificazione dati motore (possibile con motore fermo od in rotazione)
- Autotartatura on-line: compensazione dei parametri motore in funzione delle variazioni di temperatura
- Capacità sovraccarico secondo IEC 146 classe 1 e classe 2, vedere tabella a pagina 33
- Protezione termica elettronica per motore e Drive
- Funzione Multivelocità (7 programmabili)
- 5 rampe indipendenti e programmabili (lineare ed a S)
- Funzione Motopotenziometro
- Funzione di riaggancio al volo motore
- Droop Function
- Gestione doppio motore
- Blocco funzione PID
- Gestione in caso di mancanza rete mediante: arresto controllato o/e ottimizzazione dell'energia.
- Gestione I/O virtuali o remote

Configurazione di Fornitura Standard

- Tastiera di programmazione LCD o modulo di diagnostica a led
- Linea seriale RS485 integrata (protocollo ModBus RTU)
- Ingressi/Uscite standard:
 - 3 ingressi analogici differenziali programmabili (Tensione/Corrente)
 - 2 uscite analogiche programmabili
 - 8 ingressi digitali: 4 non programmabili + 4 programmabili
 - 2 uscite digitali programmabili
 - 2 uscite a relè programmabili
- Ingresso encoder integrato: sinusoidale 1Vpp (+5V) e digitale TTL (+5V)
- Software di configurazione evoluto per PC "EasyDrive" incluso:
 - programmazione in ambiente grafico dei blocchi funzione dell'inverter
 - archiviazione file utente
 - procedura di programmazione guidata per la messa in servizio mediante "Wizard"
 - visualizzazione grafica delle variabili e delle funzioni mediante "Trend recorder"
- Interfacciamento con bus di campo : ProfiBus, CANopen e DeviceNet (con scheda opzionale)
- Interruttore automatico di linea (solo versioni in armadio)
- Fusibili di rete extrarapidi (solo versioni in armadio)
- Ponte raddrizzatore e ponte inverter (separati od integrati in funzione della potenza)
- Elettromeccanica ausiliaria (solo versioni in armadio)
- Induttanza di linea (solo versioni in armadio)
- Pannello di comando in portina con (solo versioni in armadio):
 - Tastiera di programmazione
 - Tasti per Start-Stop
 - Pulsante di reset
 - Pulsante di emergenza
 - Lampada per segnalazione presenza rete ed allarmi

Accessori (Opzionali)

- Filtri EMC dedicati (in conformità alla direttiva CEE - EN61800-3)
- Resistenze di frenatura (normalizzate per l'intera gamma)
- Induttanze d'uscita (normalizzate per l'intera gamma)
- Unità di frenatura dinamica
- Personalizzazione pannello di controllo in portina

Condizioni Ambientali

- Alloggiamento:** IP23 in quadro standard
IP54 in quadro a richiesta (con filtri e/o condizionatori di raffreddamento)
IP00 per ponte inverter fornito separato
- Temperatura di esercizio:** da 0°C a 40 °C , da + 40 °C a +50 °C con derating.
- Temperatura di immagazzinaggio:**
- 250kW (300Hp) e 315kW (450Hp): -20°C...+55°C
- da 400kW (500Hp) a 630kW (700Hp): -25°C...+70°C
- Umidità:** da 5% a 85%, umidità relativa (senza condensa) o formazione di ghiaccio (classe 3K3 in accordo a EN50178)
- Altitudine:** fino a 2000 metri s.l.m.; oltre 1000 metri, la corrente deve essere ridotta del 1,2% ogni 100 metri di incremento.



Specifiche

- Vibrazioni: in base alla normativa IEC68-2-6
- Immunità alle interferenze: in base alla normativa IEC801 sezioni 2,3,4

Norme e Marchi

- CE:** conforme alla direttiva CEE sugli apparecchi a bassa tensione.
- EMC:** conforme alla direttiva CEE - EN 61800-3:2004, sulla compatibilità elettromagnetica con l'impiego dei filtri opzionali.

CE

 **Caractéristiques Générales**

Ligne "AVy (Armoire et à jour)"
- Alimentation triphasée : 400Vca - 15% - 480Vca + 10%, 50/60Hz
- Puissances du moteur :
- 250kW (300Hp)
- 315kW (450Hp)
- 400kW (500Hp)
- 500kW (600Hp)
- 630kW (700Hp)
- Version standard avec paramétrage par défaut pour des alimentations à 400V, 50Hz

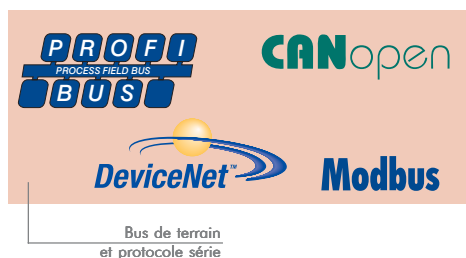

Spécifications

- Vibrations : selon la norme CEI68-2-6
- Immunité aux interférences : selon la norme CEI801 parties 2,3,4

Normes et marques

CE: conformes à la directive CEE sur les appareils en basse tension.

EMC: conformes à la directive CEE - EN 61800-3:2004, concernant la compatibilité électromagnétique avec l'utilisation des filtres en option.



Mode de contrôle

- Contrôle Vectoriel du Flux à boucle fermée :
 - codeur sinusoïdal (précision de la vitesse : 0,01%)
 - codeur digital (précision de la vitesse : 0,02%)
- Contrôle Vectoriel du flux sans rétroaction par codeur (Sensorless) (précision de la vitesse : 0,1% au-dessus de 100 t/mn, 0,2% au-dessous de 100 t/mn)
- Contrôle progressif V/f (précision de la vitesse en fonction du glissement du moteur)

Fonctions principales de contrôle et de régulation

- Fréquence de sortie : 200Hz avec et sans rétroaction par codeur
- Calibrage automatique off-line : des régulateurs de vitesse-courant-flux et identification des données moteur (possible avec moteur à l'arrêt ou moteur en phase de rotation)
- Calibrage automatique on-line : compensation des paramètres moteur en fonction des variations de température
- Capacité surcharge selon CEI 146 classe 1 et classe 2, voir le tableau de la page 33
- Protection thermique électronique pour moteur et Drive
- Fonction multivitesse (7 programmables)
- 5 rampes indépendantes et programmables (linéaire et en S)
- Fonction Motopotentiomètre
- Fonction de redémarrage au vol du moteur
- Droop Function
- Gestion double moteur
- Bloc fonction PID
- Gestion en cas de coupure de réseau par : arrêt contrôlé et/ou optimisation de l'énergie.
- Gestion E/S virtuelles ou à distance

Configuration en fourniture standard

- Clavier de programmation LCD ou module de diagnostic à led
- Ligne série RS485 intégrée (protocole Modbus RTU)
- Entrées/Sorties standards :
 - 3 entrées analogiques différentielles programmables (Tension/Courant)
 - 2 sorties analogiques programmables
 - 8 entrées digitales : 4 non programmables + 4 programmables
 - 2 sorties numériques programmables
 - 2 sorties à relais programmables
- Entrée codeur intégré : sinusoïdal 1Vpp (+5V) et digital TTL (+5V)
- Logiciel de configuration de pointe pour PC "EasyDrive" compris :
 - programmation dans le milieu graphique des blocs fonction du variateur
 - archivage des fichiers utilisateur
 - procédure de programmation guidée pour la mise en service par la "Wizard"
 - visualisation graphique des variables et des fonctions par "Trend recorder"
- Interface par bus de terrain : ProfiBus, CANopen et DeviceNet (avec carte optionnelle)
- Interrupteur automatique de ligne (seulement pour les versions en armoire)
- Fusibles de réseau ultra rapides (seulement pour les versions en armoire)
- Pont redresseur et pont variateur (séparés ou intégrés en fonction de la puissance)
- Electromécanique auxiliaire (seulement pour les versions en armoire)
- Inductance de ligne (seulement pour les versions en armoire)
- Console de commande dans porte avec (seulement pour les versions en armoire) :
 - Clavier de programmation
 - Touches pour Start-Stop
 - Bouton de réinitialisation
 - Bouton d'arrêt d'urgence
 - Lampe pour signalisation présence réseau et alarmes

Accessoires (Options)

- Filtres EMC spéciaux (conformes à la directive CEE - EN61800-3)
- Résistances de freinage (normalisées pour toute la gamme)
- Inductances de sortie (normalisées pour toute la gamme)
- Unité de freinage dynamique
- Personnalisation de la console de contrôle dans la porte

Conditions d'environnement

Logement : IP23 dans armoire standard
IP54 dans armoire sur demande (avec filtres et/ou climatiseurs pour le refroidissement)
IP00 pour pont variateur fourni séparément

Température de service : de 0°C à 40 °C, de + 40 °C à +50 °C avec déclassement.

Température de stockage :

- 250kW (300Hp) et 315kW (450Hp) : -20°C...+55°C
- de 400kW (500Hp) à 630kW (700Hp) : -25°C...+70°C

Humidité : de 5% à 85%, humidité relative (sans condensation) ou formation de glace (classe 3K3 conformément à la norme EN50178)

Altitude : jusqu'à 2000 mètres au-dessus du niveau de la mer; au-delà de 1000 mètres, le courant doit être diminué de 1,2% tous les 100 mètres supplémentaires.

Cabinet & Open Frame Versions

Serie "AVy (Schrank- und Freiluftausführung)"

- Dreiphasige Versorgung:
400 V_{AC} -15% ... 480 V_{AC} +10%, 50/60Hz
- Motorleistungen:
 - 250kW (300Hp)
 - 315kW (450Hp)
 - 400kW (500Hp)
 - 500kW (600Hp)
 - 630kW (700Hp)
- Standardversion mit Voreinstellung für 400 V_{AC}, 50 Hz Versorgung

Regelungsarten

- Vektorielle Flussregelung mit geschlossenem Regelkreis:
 - Sinusencoder (Drehzahlgenauigkeit: 0,01 %)
 - Digitalencoder (Drehzahlgenauigkeit: 0,02 %)
- Vektorielle Flussregelung ohne Encoderrückführung (Sensorless) (Drehzahlgenauigkeit: 0,1 % über 100 min⁻¹, 0,2 % unter 100 min⁻¹)
- Skalare U/f-Regelung (Drehzahlgenauigkeit in Funktion des Motorschlupfs)

Wichtigste Steuer- und Regelfunktionen

- Ausgangsfrequenz: 200 Hz mit und ohne Encoderrückführung
- Inbetriebnahmefunktion: Adaption der Drehzahl-Strom-Flussregler und Motordatenidentifizierung (möglich bei still stehendem oder drehendem Motor)
- Online-Adaption: Anpassung der Motorparameter als Funktion der Temperaturänderungen
- Überlastkapazität gemäß IEC 146 Klasse 1 und Klasse 2, siehe Tabelle auf Seite 33
- Elektronischer Wärmeschutz für Motor und Antrieb
- 7 programmierbare Drehzahlen
- 5 unabhängige, programmierbare Rampen (linear und s-förmig)
- Funktion Motorpotentiometer
- Aufschalten auf drehenden Motor
- Lastaufteilung bei mechanisch gekoppelten Motoren
- 2 Motorparametersätze
- zusätzlicher, frei programmierbarer PID-Regler
- Verhalten bei Netzausfall programmierbar: gesteuertes Anhalten und/oder Energieoptimierung.
- Einbindung virtueller oder entfernt liegender I/O (Feldbus)

Konfiguration Standardlieferung

- LCD-Programmierbedieneinheit oder LED-Diagnosemodul
- Integrierte serielle RS485 Schnittstelle (ModBus RTU Protokoll)
- Standardeingänge/-ausgänge:
 - 3 programmierbare Differential-Analogaingänge (Spannung/Strom)
 - 2 programmierbare Analogausgänge
 - 8 Digitaleingänge: 4 nicht programmierbare + 4 programmierbare
 - 2 programmierbare Digitalausgänge
 - 2 programmierbare Relaisausgänge
- Integrierter Encodereingang: Sinusencoder 1V_{pp} (+5 V) und Digitalencoder TTL (+5 V)
- Konfigurationssoftware für PC "EasyDrive" inklusive:
 - Programmierung der Frequenzrichter-Funktionsblöcke in graphischer Umgebung
 - Benutzerdateiarchivierung
 - Inbetriebnahme durch "Wizard"-Funktion
 - Graphische Anzeige der Variablen über die Oszilloskopfunktion "Trend recorder"
- Feldbusschnittstelle: ProfiBus, CANopen und DeviceNet (mit Optionskarte)
- Automatischer Leitungsschalter (nur bei Schrankausführungen)
- Extralinke Netzsicherungen (nur bei Schrankausführungen)
- Gleichrichter- und Frequenzrichterbrücke (je nach Leistung separat oder integriert)
- Zusätzliche Elektromechanik (nur bei Schrankausführungen)
- Leitungsdrossel (nur bei Schrankausführungen)
- Steuertafel in der Tür mit (nur bei Schrankausführungen):
 - Programmier-Bedieneinheit
 - Start-Stopp-Tasten
 - Resetknopf
 - Notstopptaste
 - LEDs für Netzversorgungs- und Alarmanzeige

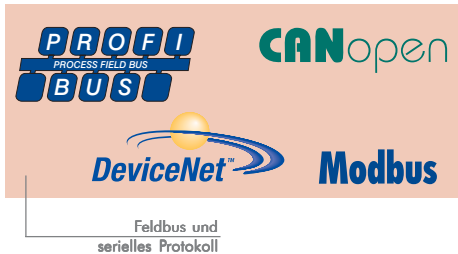

Spezifikationen

- Vibrationen: entsprechend IEC68-2-6
- Störfestigkeit: entsprechend IEC801 Abschnitte 2,3,4

Normen und Marken

- CE:** entspricht der EG-Richtlinie über Geräte mit Niederspannung.
- EMC:** entspricht der EG-Richtlinie – EN 61800-3:2004 über die elektromagnetische Verträglichkeit mit dem Einsatz optionaler Filter.



Zubehörteile (optional)

- spezielle EMV-Filter (gemäß EG Richtlinie – EN 61800-3:2004)
- Bremswiderstände (für die gesamte Produktpalette genormt)
- Ausgangsnetz-drosseln (für die gesamte Produktpalette genormt)
- Dynamischer Bremskreis
- Anwendungsbezogene Steuertafel in der Tür

Umgebungsbedingungen

- Gehäuse:** IP23 für Standard-Schalttafel
IP54 für Schalttafel auf Anfrage (mit Filtern und/oder Klimatisierungsgeräten für Kühlung)
IP00 für separat gelieferte Frequenzrichterbrücke
- Betriebstemperatur:** von 0° C bis 40° C, von + 40° C bis +50° C mit Leistungsreduktion.
- Lagerungstemperatur:** - 250 kW (300 Hp) und 315 kW (450 Hp): -20° C...+55° C
- von 400 kW (500 Hp) bis 630 kW (700 Hp): -25° C...+70° C
- Feuchtigkeit:** von 5 % bis 85 %, relative Feuchtigkeit (ohne Betauung) oder Eisbildung (Klasse 3K3 entsprechend EN50178)
- Installationshöhe:** bis zu 2000 Metern ü.d.M.; über 1000 Metern, muss der Strom pro 100 Höhenmeter um 1,2 % verringert werden.

 Características Generales

Línea "AVy (Armario y por día)"	
- Alimentación trifásica:	400Vac -15% ... 480Vac +10%, 50/60Hz
- Potencia del motor:	
-	250kW (300CV)
-	315kW (450CV)
-	400kW (500CV)
-	500kW (600CV)
-	630kW (700CV)
- Versiones "AVy" con configuración por defecto para la alimentación a 400V, 50Hz	



Especificaciones

- Vibraciones: en cumplimiento de la normativa IEC68-2-6
- Inmunidad frente a interferencias: en cumplimiento de la normativa IEC801 secciones 2,3,4

Normas y marcas

- CE:** de acuerdo con la directiva CEE en los equipos de baja tensión
- EMC:** de acuerdo con la directiva CEE - EN 61800-3:2004, sobre la compatibilidad electromagnética con el empleo de filtros opcionales.



Modalidad de control

- Control vectorial del flujo en bucle cerrado:
 - encoder sinusoidal (precisión de velocidad: 0,01%)
 - encoder sinusoidal (precisión de velocidad: 0,02%)
- Control vectorial de flujo sin realimentación de encoder (Sensorless) (precisión de velocidad: 0,1% por debajo de 100rpm, 0,2% por debajo de 100rpm)
- Control escalon V/f (precisión de velocidad en función del deslizamiento del motor)

Función de control y regulaciones principales

- Frecuencia de salida: 200Hz con y sin realimentación de encoder
- Calibración automática off-line: de los reguladores de velocidad-intensidad-flujo e identificación de datos de los motores (posible con motores parados y en rotación)
- Calibración automática on-line: compensación de los parámetros de los motores en función de las variaciones de temperatura
- Capacidad de sobrecarga según las directrices IEC 146 Clase 1 y Clase 2, consulte la tabla de la página 33
- Protección térmica electrónica para motor y Drive
- Función multivelocidad (7 programaciones)
- 5 rampas independientes y programables (lineales y en S)
- Función Motopotenciómetro
- Función de reenganche del motor al vuelo
- Función Droop
- Gestión doble motor
- Bloqueo función PID
- Gestión en caso de fallo red mediante: parada controlada y/o optimización de la energía
- Gestiones de E/S virtuales o remotas

Configuración de entrega estándar

- Teclado de programación LCD o módulo de diagnóstico por leds
- Línea serie RS485 integrada (protocolo Modbus RTU)
- Entradas/Salidas estándar:
 - 3 entradas analógicas diferenciales programables (Tensión/Intensidad)
 - 2 salidas analógicas programables
 - 8 entradas digitales: 4 no programables + 4 programables
 - 2 salidas digitales programables
 - 2 salidas de relé programables
- Entrada de encoder integrada: sinusoidal 1Vpp (+5V) y digital TTL (+5V)
- Software de configuración avanzado para PC "EasyDrive" incluido:
 - programación en entorno gráfico de los bloques de funciones del inverter
 - archivación de los archivos de salida
 - procedimiento de programación asistida para la puesta en servicio por medio de la función de asistente, "Wizard"
 - visualización gráfica de las variables y las funciones a través de "Trend recorder"
- Interfaz con bus de campo: Profibus, CANopen y DeviceNet (con tarjeta opcional)
- Interruptor automático de línea (sólo versiones en armario)
- Fusible de red automático (sólo versiones en armario)
- Puente rectificador y puente inverter (separado o integrado en función de la potencia)
- Electromecánica auxiliar (sólo versiones en armario)
- Inductancia de línea (sólo versiones en armario)
- Panel de control plegable con (solo versiones en armario):
 - Teclado de programación
 - Botón "Start/stop"
 - Tecla de reinicio (reset)
 - Tecla de emergencia
 - Lámpara de señalización de la presencia de red y alarma

Accesorios (Opcionales)

- Filtros EMC dedicados (según la normativa europea (CEE - EN 61800-3:2004)
- Resistencia de frenado (normalizada para toda la gama)
- Inductancia de salida (normalizada para toda la gama)
- Unidad de freno dinámico
- Personalización del panel de control plegable

Condiciones ambientales

- Alojamiento:** IP23 en cuadro estándar
IP54 en cuadro bajo pedido (con filtro y/o acondicionador de refrigeración)
IP00 para puente inverter suministrado por separado
- Temperatura de ejercicio:** de 0°C a 40 °C , de + 40 °C a +50 °C con reducción.
- Temperatura de almacenamiento:**
- 250kW (300CV) y 315kW (450CV): -20°C...+55°C
 - desde 400kW (500CV) a 630kW (700CV): -25°C...+70°C
- Humedad:** del 5% al 85%, humedad relativa (sin condensación) o formación de hielo (clase 3K3 en cumplimiento de la normativa EN50178)
- Altura:** hasta 2000 metros por encima del nivel del mar; para altitudes superiores 1000 m asegurarse de que la corriente se reduce un 1,2% por cada 100 metros de altura adicionales.

Cabinet & Open Frame Versions

Scelta dell'Inverter
Sélection du Variateur
Wahl des Frequenzumrichters
Selección del Convertidor de
Frecuencia



Co-ordination of the nominal power rating for a motor with the type of inverter that is referred to in the table will require use of motors that operate at a voltage corresponding to the nominal values of the power supply network.
For motors that operate at other voltages, the type of inverter that is selected will depend on the nominal current of the motor to be controlled.

The combination put forward in the table, therefore reflects, as a function of the power supply voltage, the value of current the drive is able to supply operating conditions (IEC146 Class 1) and under overload conditions (IEC146 Class 2).

Analogous dimensioning criteria are applicable for any operations to which additional downgrading factors are applicable: KV (Power supply voltage), KT (Ambient temperature), KF (Switching frequency).



Il coordinamento delle potenze nominali del motore con il tipo di inverter riportato in tabella, prevede l'impiego di motori con tensione nominale corrispondente alla nominale della rete di alimentazione.

Per motori con tensione differente, la scelta dell'inverter dovrà essere effettuata in base alla corrente nominale del motore stesso.

L'abbinamento suggerito in tabella, riporta quindi in funzione della tensione di alimentazione, il valore di corrente erogabile dal drive in condizioni di funzionamento continuativo (IEC146 Classe1) ed in condizioni di sovraccarico (IEC146 Classe 2).

Criteri di dimensionamento analoghi, vengono applicati per operazioni con fattori di declassamento addizionali: KV (Tensione di alimentazione), (KT) Temperatura ambiente e (KF) Frequenza di switching.



La coordination des puissances nominales du moteur avec le type du variateur figurant dans le tableau, prévoit l'utilisation de moteurs ayant une tension nominale correspondant à la tension nominale du réseau d'alimentation.

Pour les moteurs ayant une tension différente, la sélection du variateur doit être effectuée en fonction du courant nominal du moteur.

La sélection suggérée dans le tableau, indique, en fonction de la tension d'alimentation, la valeur du courant fourni par le variateur dans des conditions d'un service continu (IEC146 Classe1) et dans des conditions de surcharge (IEC146 Classe 2).

Des critères de dimensionnement analogues sont appliqués pour les opérations avec des facteurs de déclassement supplémentaires : KV (Tension d'alimentation), KT (Température ambiante) et KF (Fréquence de commutation).



Die angegebene Motornennleistung gilt bei Übereinstimmung der Motornennspannung mit der Netz-Nennspannung.

Für Motoren mit einer anderen Spannung muss der Frequenzumrichter ausgehend vom Motor-Nennstrom gewählt werden.

Die laut Tabelle empfohlene Kombination zeigt daher den vom Antrieb je nach Versorgungsspannung lieferbaren Stromwert, unter kontinuierlichen Betriebsbedingungen (IEC146 Klasse1) und unter Überlastbedingungen (IEC146 Klasse 2).

Weitere Bemessungskriterien werden für den Betrieb mit zusätzlichen Anpassungsfaktoren angewendet: KV (Versorgungsspannung), KT (Umgebungstemperatur) und KF (Schalffrequenz).



La coordinación de la potencia nominal del motor con el tipo de inverter al que se refiere la tabla, requerirá el uso de motores que operen con una tensión nominal correspondiente a los valores nominales del resto de alimentación.

Para motores que operen con otras tensiones, el tipo de inverter seleccionado, debería depender de la intensidad nominal del motor en cuestión

La combinación reflejada en la siguiente tabla refleja, en función de la tensión de alimentación, el valor de corriente que el equipo es capaz de suministrar bajo continuas condiciones de operación (IEC 146 Clase 1) y bajo condiciones de sobrecarga (IEC146 Clase 2).

Se aplica un criterio de dimensiones análogas aplicable en cada operación en la cual los factores degradantes sean aplicables: KV (Tensión de alimentación), KT (Temperatura ambiente) y KF (Frecuencia de arranque).

AVy...-IPXX, Output data

Dati in Uscita
Caractéristiques de Sortie

Ausgangsdaten
Datos de Salida

Drive Type	Inverter Output (IEC 146 class 1), Continuous service (@ 400 VAC)	Inverter Output (IEC 146 class 2), 150% overload for 60s (@ 400 VAC)	P _N mot (recommended motor output):				U ₂ Max output voltage	f ₂ Max output frequency	I _{2N} Rated output current :				f _{sw} switching frequency (Default)	f _{sw} switching frequency (Higher)	Derating factor : Temp. Factor K _T for ambient temperature
			@ U _{LN} =400 VAC; f _{sw} =default; IEC 146 class 1	@ U _{LN} =400 VAC; f _{sw} =default; IEC 146 class 2	@ U _{LN} =460 VAC; f _{sw} =default; IEC 146 class 1	@ U _{LN} =460 VAC; f _{sw} =default; IEC 146 class 2			@ U _{LN} =400 VAC; f _{sw} =default; IEC 146 class 1	@ U _{LN} =400 VAC; f _{sw} =default; IEC 146 class 2	@ U _{LN} =460 VAC; f _{sw} =default; IEC 146 class 1	@ U _{LN} =460 VAC; f _{sw} =default; IEC 146 class 2			
AVy	kVA	kVA	kW	kW	Hp	Hp	V	Hz	A	A	A	A	kHz	kHz	K _T
92500	335	305	250	250	350	300		200	485	441	422	384	4		
93150	400	363	315	250	450	450		200	580	525	566	515	2		
104000	554	504	400	400	600	500		200	800	728	720	655	2		
105000	685	623	500	500	700	600		200	980	892	853	776	2		
106300	(1)	776	(1)	630	(1)	700		200	(1)	1120	(1)	974	2	no setting	0.8 @ 50°C (122°F)
92500-C-IP00	335	305	250	250	350	350	0.98 x U _{LN} (AC Input voltage)	200	485	441	422	384	2		
93150-CP-IP00	400	363	315	250	450	350		200	580	527	566	515	2		



(1) : AVy106300 can be used only with class 2 service condition.



(1) : AVy106300 kann nur mit Betriebsklasse 2 eingesetzt werden.



(1) : AVy106300 può essere impiegato unicamente con la classe di servizio 2.



(1) : AVy106300 se puede utilizar únicamente con la clase de servicio 2.



(1) : AVy106300 peut être utilisé uniquement avec la classe de service 2.

AVy	Overload capacity IEC 146 class 1	Overload capacity IEC 146 class 2
92500	$I_{MAX} = 1.36 * I_{CONT} 60sec$	$I_{MAX} = 1.5 * I_{CONT} 60sec$
93150	$I_{MAX} = 1.36 * I_{CONT} 60sec$	$I_{MAX} = 1.5 * I_{CONT} 60sec$
104000	$I_{MAX} = 1.48 * I_{CONT} 60sec$	$I_{MAX} = 1.63 * I_{CONT} 60sec$
105000	$I_{MAX} = 1.20 * I_{CONT} 60sec$	$I_{MAX} = 1.32 * I_{CONT} 60sec$
106300	No Overload	$I_{MAX} = 1.06 * I_{CONT} 60sec$
92500-C-IP00	$I_{MAX} = 1.36 * I_{CONT} 60sec$	$I_{MAX} = 1.5 * I_{CONT} 60sec$
93150-CP-IP00	$I_{MAX} = 1.13 * I_{CONT} 60sec$	$I_{MAX} = 1.25 * I_{CONT} 60sec$

Inverter Selection

AVy...-IPXX, Input data

Dati in Ingresso
Caractéristiques d'Entrée

Eingangsdaten
Datos de Entrada

Drive Type	U_{LN} AC Input voltage	Voltage balance	AC Input frequency	I_N AC Input current @ 400 V _{AC}	I_N AC Input current @ 460 V _{AC}	Interrupt short circuit current
AVy	V	%	Hz	A	A	kA
92500	4000 V _{AC} - 15% ... 480 V _{AC} + 10%, 3Ph	3	50/60 Hz ±5%	520	425	18
93150		3		600	560	30
104000		3		850	740	40
105000		3		1050	910	50
106300		3		1190	1040	60
92500-C-IP00		3		520	425	18
93150-CP-IP00		3		600	560	30



Devices may be used on a circuit capable of only supplying symmetrical amps in milliseconds as shown in the table (maximum 460 volts).



Gli apparecchi possono essere utilizzate su un circuito in grado di fornire unicamente gli ampere simmetrici in millisecondi indicati in tabella (massimo 460 Volt).



Les appareils peuvent être utilisés sur un circuit à même de fournir uniquement les ampères symétriques en millisecondes indiqués dans le tableau (maximum

460 Volts).



Die Geräte können in einem Netz verwendet werden, das eine symmetrische Kurzschlussleitung gleich oder niedriger laut Tabelle liefern kann (bei maximal 460 Volt).



Los equipos se pueden utilizar en un circuito que entregue únicamente los amperios de forma simétrica en los milisegundos indicados en la tabla (máximo 460 Voltios).

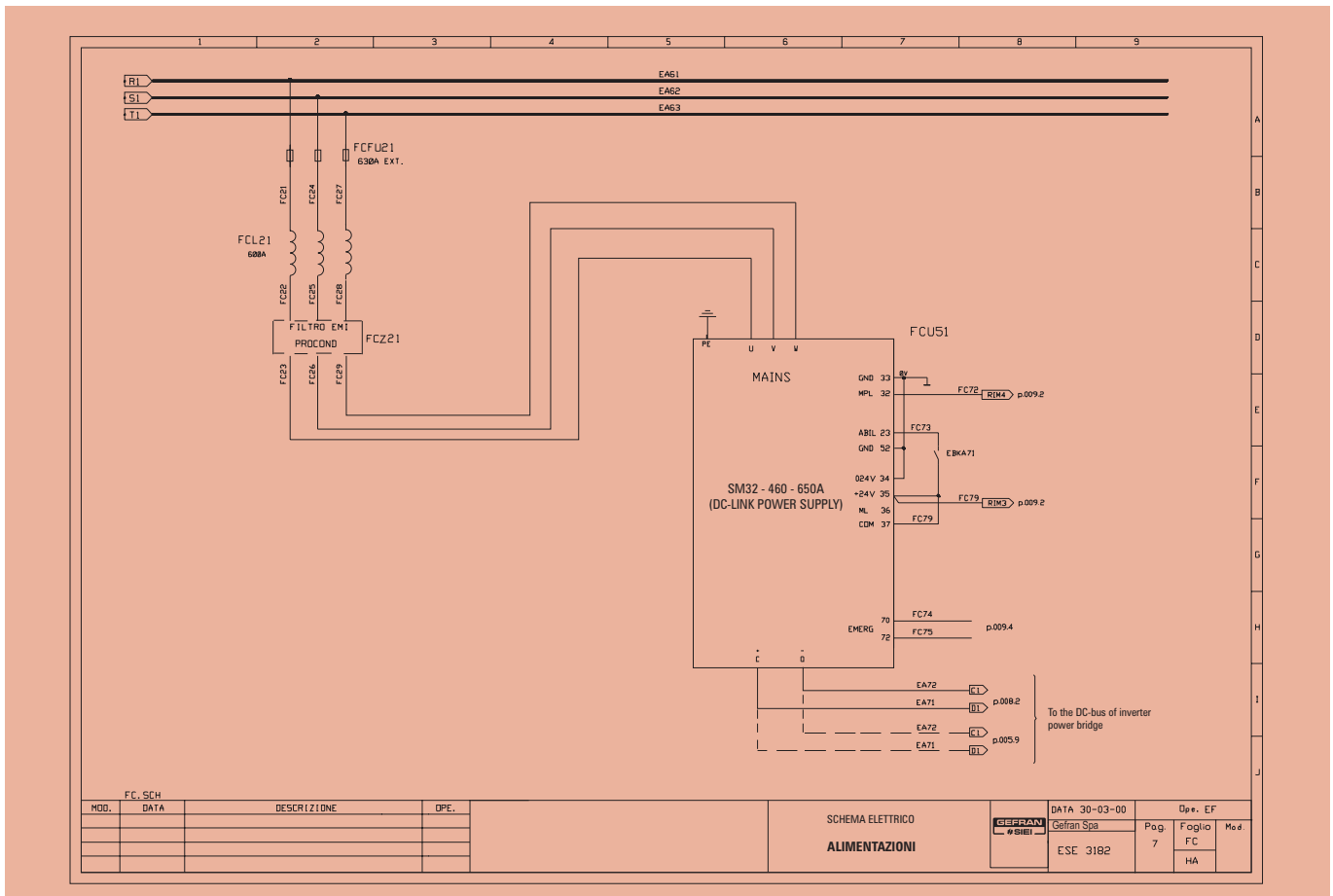
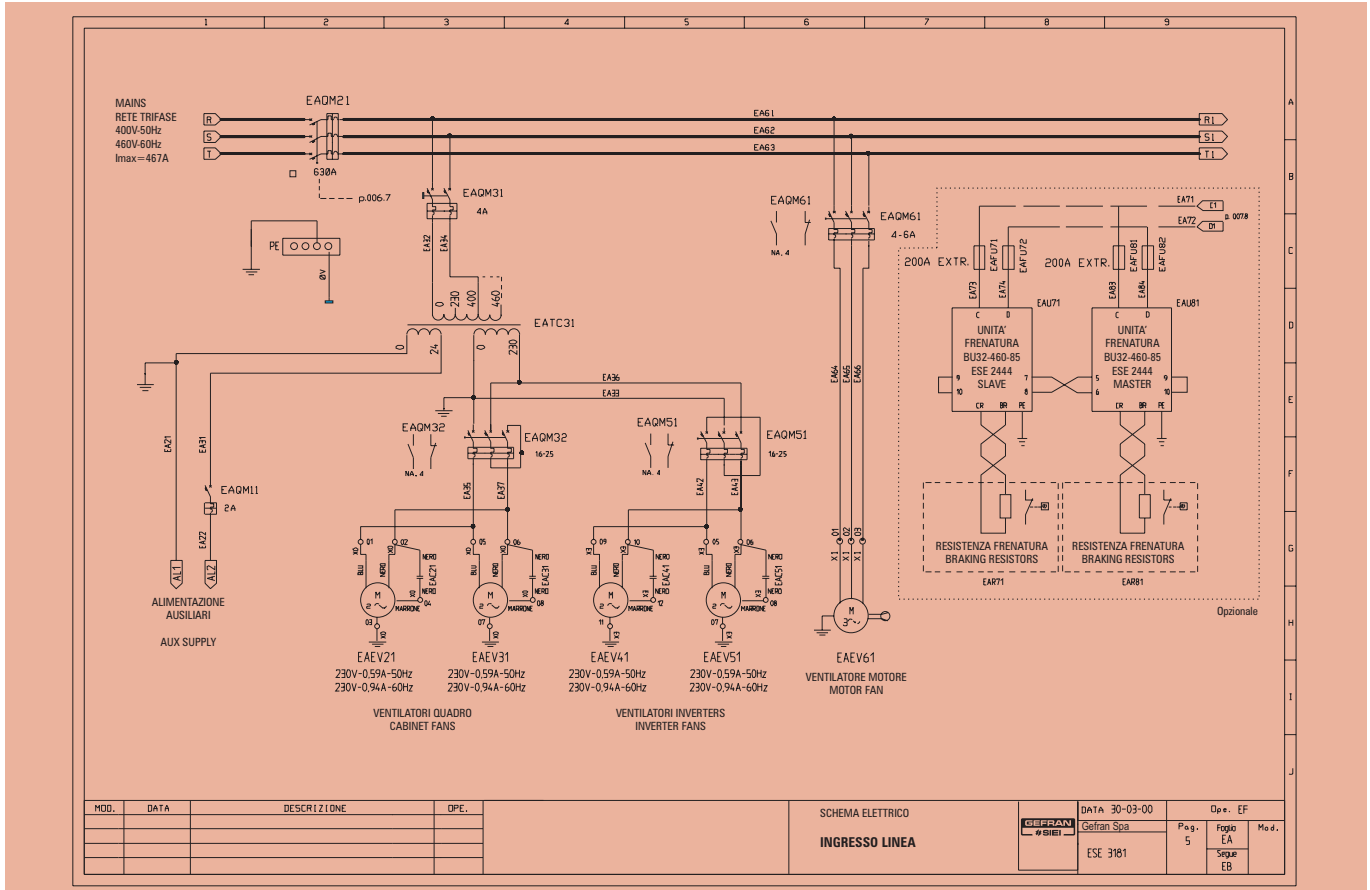

Cabinet & Open Frame Versions

Typical Connection Scheme

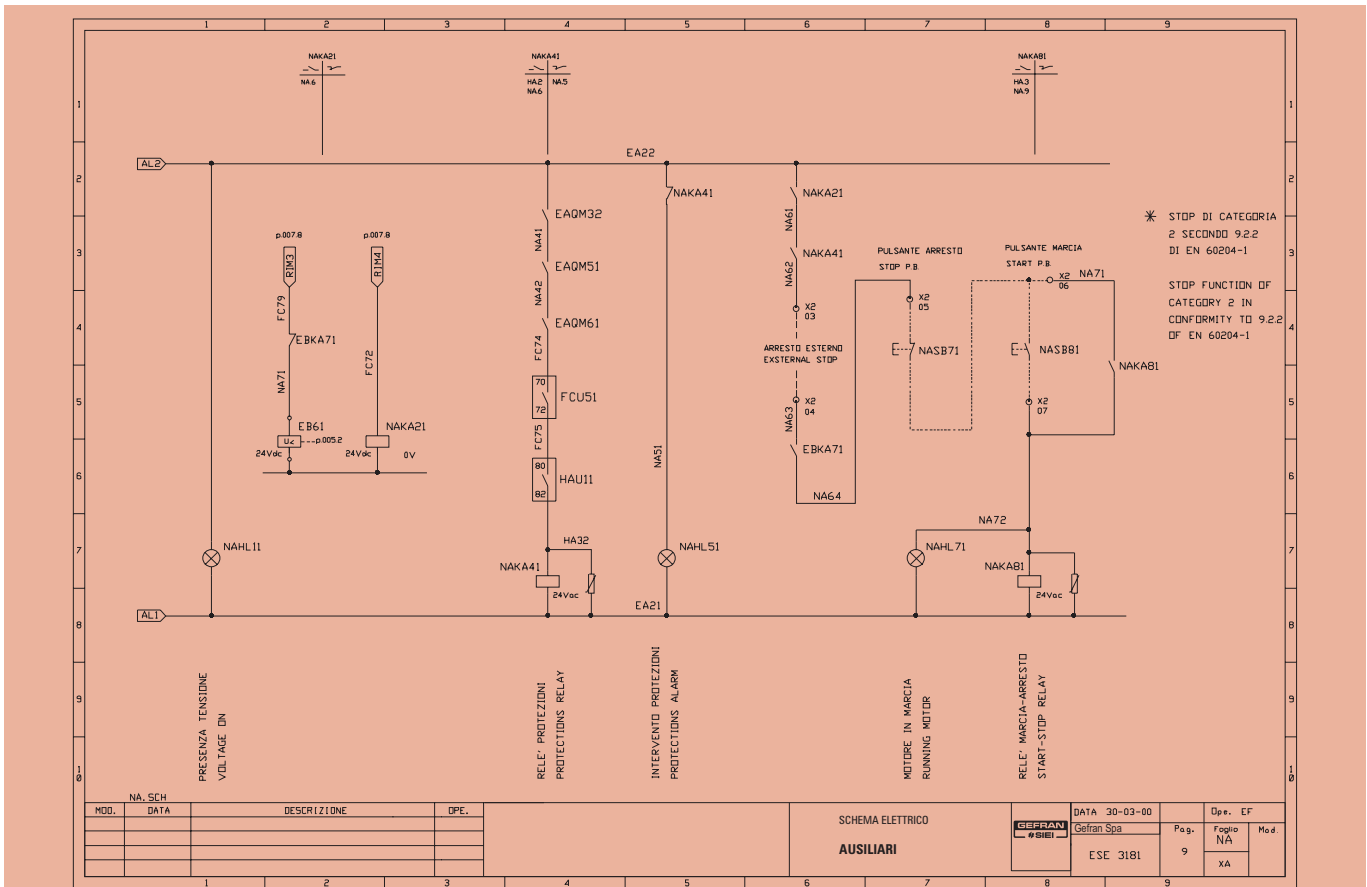
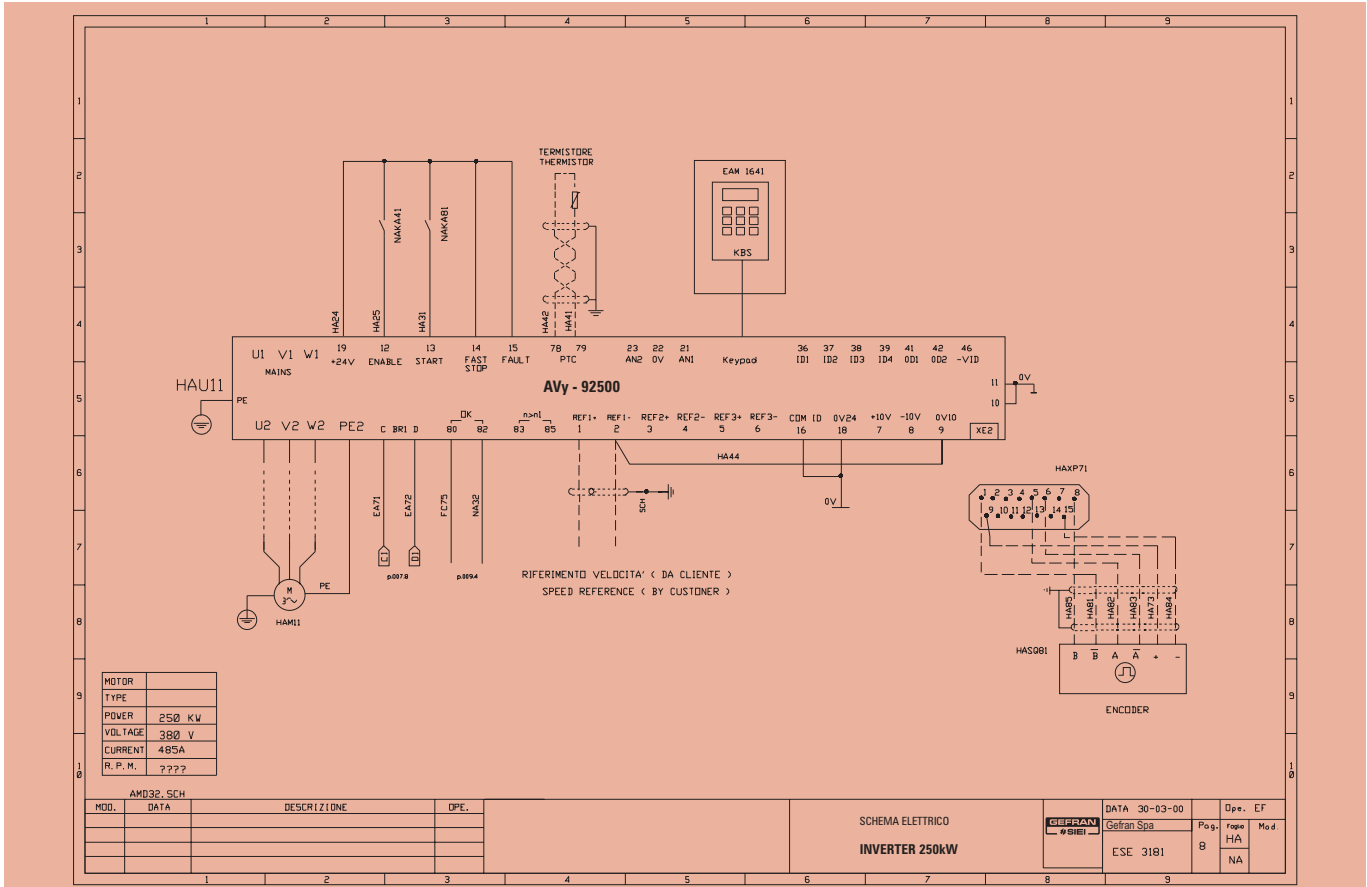

Cabinet & Open Frame Versions

 These diagrams are typical of the AVy92500 and AVy93150 drives.
  Diese Pläne enthalten Richtangaben für die Antriebe AVy92500 und AVy93150.





 Questi schemi sono indicativi per i drive AVy92500 e AVy93150.
  Estos esquemas son indicativos para los drives AVy92500 y AVy93150.

 Ces schémas sont indicatifs pour les drives AVy92500 et AVy93150.

Dimensions and Weights

AVy...-C-IP00, AVy...-CP-IP00

Dimensioni e Pesì
Dimensions et Poids
Abmessungen und Gewichte
Dimensiones y Pesos

-  Note: input rectifier included.
(D):Wall mounting
-  Nota: incluso ponte in ingresso.
(D):Montaggio a muro.
-  Remarque : y compris le pont à l'entrée.
(D):Montage au mur.
-  Hinweis: Einschließlich Brücke im Eingang.
(D):Wandmontage.
-  Nota: incluido el puente en entrada.
(D):Montaje a la pared.

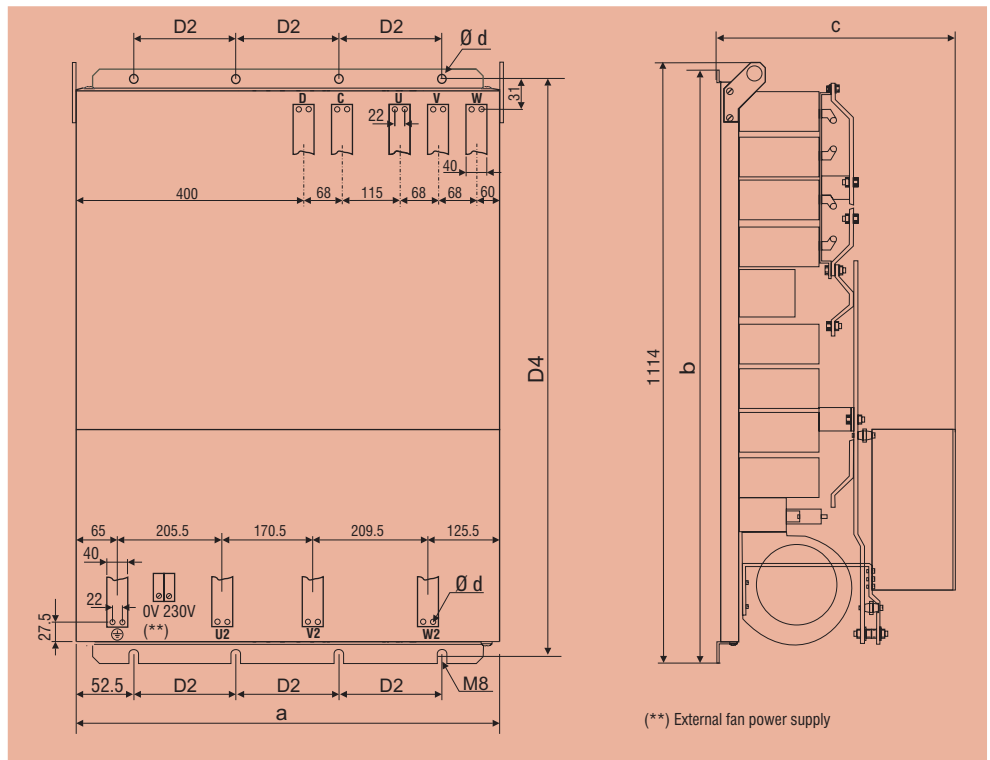





Type	Dimensions mm [inch]								Weight kg [lbs]
	a	b	c	D1	D2	D3	D4	Ø d	
AVy92500-C-IP00	776 [30.6]	1091 [43]	430 [16.9]	-	225 [8.9]	-	1075 [42.3]	M8	...
AVy93150-CP-IP00	776 [30.6]	1091 [43]	430 [16.9]	-	225 [8.9]	-	1075 [42.3]	M8	...

Dimensions and Weights

AVy10400-...-IP00, AVy10500-...-IP00,
AVy106300-...-IP00

Dimensioni e Pesì
Dimensions et Poids
Abmessungen und Gewichte
Dimensiones y Pesos

-  Inverter bridge only, power supply not included.
-  Solo ponte inverter, alimentatore non incluso.
-  Uniquement pont variateur, alimentateur non compris.
-  Nur Frequenzrichterbrücke, Speisung nicht mitinbegriffen.
-  Sólo puente inverter, alimentador no incluido.

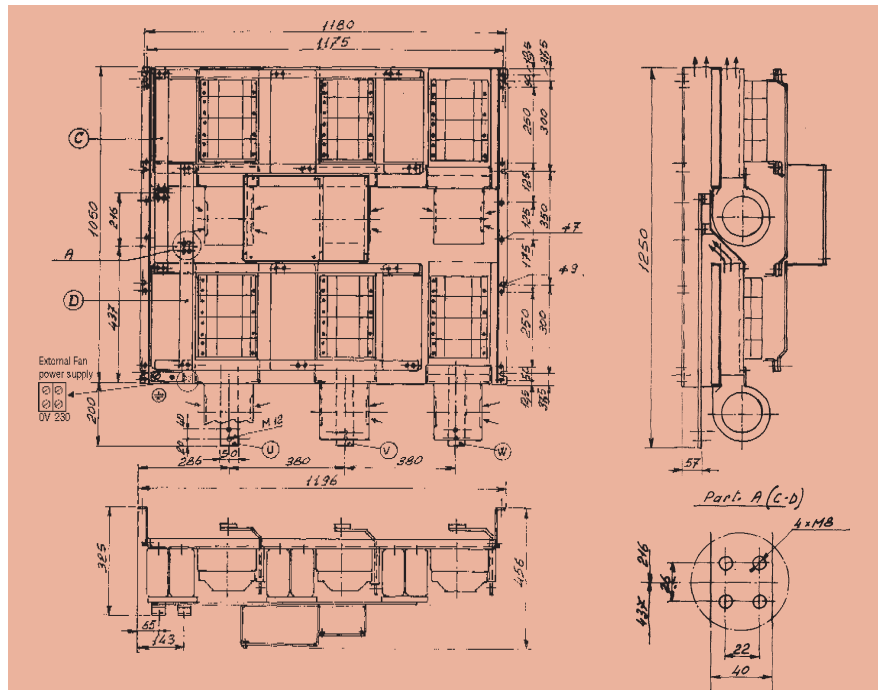

Type	Dimensions mm [inch]			Weight kg [lbs]
	Height	width	depth	
AVy10400-...-IP00	1196 [47]	1250 [49.12]	456 [17.92]	193 [425.37]
AVy10500-...-IP00	1196 [47]	1250 [49.12]	456 [17.92]	193 [425.37]
AVy106300-...-IP00	1196 [47]	1250 [49.12]	456 [17.92]	193 [425.37]

Cabinet & Open Frame Versions

Dimensions and Weights

AVy...-IP23, AVy...-IP54

Dimensioni e Pes
Dimensions et Poids
Abmessungen und Gewichte
Dimensiones y Pesos

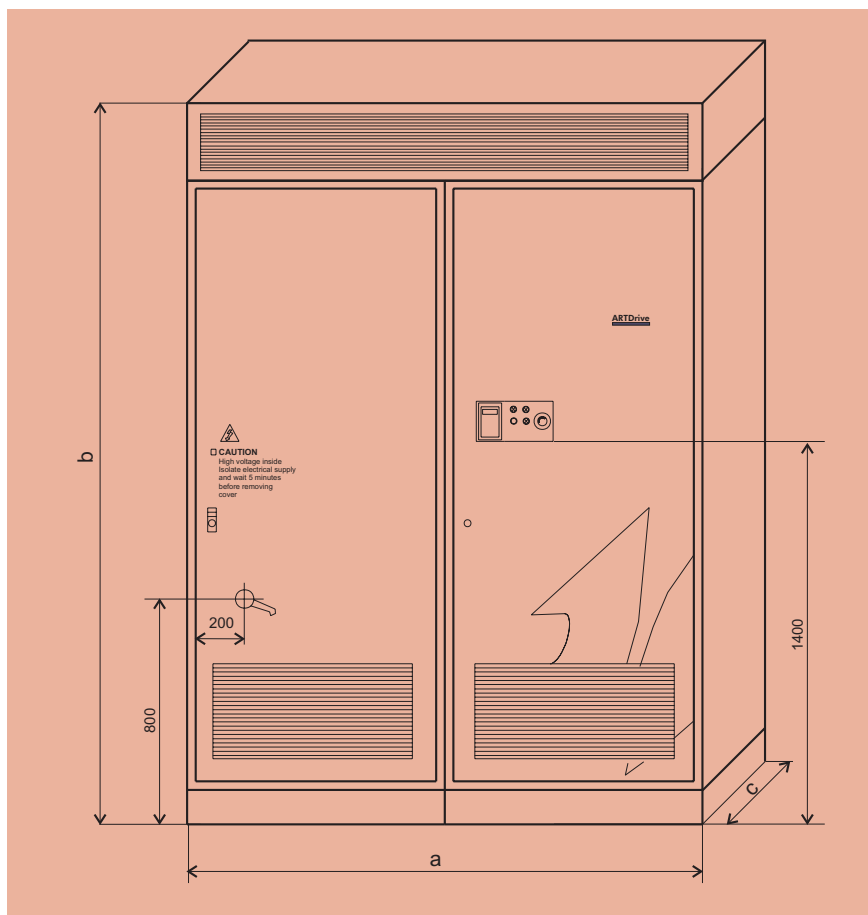

 The dimensions are given as an indication and relate to a typical configuration in a double-door side cabinet. Lifting hooks are mounted on the cabinet (IP23 and IP54) for the transportation of the device. The total height must be increased by 2 inches (50mm), to allow for the hooks.

 Le dimensioni sono indicative e sono riferite ad una configurazione tipica in armadio a doppia anta laterale. Sull'armadio (IP23 e IP54) vengono montati dei ganci di sollevamento per il trasporto del dispositivo. L'altezza totale deve essere aumentata di 50 mm per permettere l'installazione dei ganci.

 Les dimensions sont indicatives et se réfèrent à une configuration type dans une armoire à double porte latérale. Des crochets de levage, pour le transport du dispositif, sont installés sur l'armoire (IP23 et IP54). La hauteur totale doit être augmentée de 50 mm pour permettre l'installation des crochets.

 Die Abmessungen sind Richtangaben und beziehen sich auf eine typische Konfiguration im Schaltschrank mit doppelter Seitentür. Am Schrank (IP23 und IP54) werden Haken zum Hochheben der Vorrichtung zu Transportzwecken montiert. Die Gesamthöhe muss um 50 mm erhöht werden, um die Montage der Haken zu ermöglichen.

 Las dimensiones son indicativas y se refieren a una configuración típica en armario con doble puerta lateral. En el armario (IP23 y IP54) están instalados ganchos para levantar y transportar el dispositivo. La altura total se debe aumentar en 50 mm para permitir la instalación de los ganchos.

Type	Dimensions mm [inch]			Colour	Weight kg [lbs]
	a	b	c		
AVy92500-...-IP23	1600 [62.88]	2200 [86.46]	600 [23.58]	Grey RAL 7024	850 [1873.4]
AVy92500-...-IP54	For information refer to Gefran-Siei commercial offices				
AVy93150-...-IP23	1600 [62.88]	2200 [86.46]	600 [23.58]	Grey RAL 7024	850 [1873.4]
AVy93150-...-IP54	For information refer to Gefran-Siei commercial offices				
AVy104000-...-IP23	2400 [94.32]	2400 [94.32]	800 [31.44]	Grey RAL 7024	
AVy105000-...-IP23	2400 [94.32]	2400 [94.32]	800 [31.44]	Grey RAL 7024	
AVy106300-...-IP23	2400 [94.32]	2400 [94.32]	800 [31.44]	Grey RAL 7024	

Technical Specifications

Inverter Dissipation and Fan Flow

Dissipazione Inverter e Portata Ventilatori
Dissipation du Variateur et Débit des Ventilateurs

Frequenzumrichter-Verlustleistung und Lüfterleistung
Disipación del Convertidor de Frecuencia y Ventilación forzada

Drive Type	P _V Heat dissipation (f _{sw} =default; I ₂ =I _{2N}):				Airflow of fan		Minimum cooling opening	
	@U _{LN} =230 V _{AC}	@U _{LN} =400 V _{AC}	@U _{LN} =460 V _{AC}	@U _{LN} =575 V _{AC}	Internal fan	Heatsink fans (50Hz)	Control section	Heatsink
AVy ... -4 / -4A (230V...480V)	W	W	W	W	m ³ / h	m ³ / h	cm ² (sq.inch)	cm ² (sq.inch)
AVy92500	-	6300 max	5607 max	-	-	n.4 x 1500		
AVy93150	-	7990 max	7820 max	-	-	n.4 x 1500		
AVy104000	-	8000 max	8000 max	-	-	n.6 x 700		
AVy105000	-	10000 max	10000 max	-	-	n.6 x 700		
AVy106300	-	12600 max	12600 max	-	-	n.6 x 700		
AVy92500-C-IP00	-	6400 max	5700 max	-	-	-		
AVy93150-CP-IP00	-	8000 max	7900 max	-	-	-		



Introduction

AVy ARTDrive inverters are also available in a series of special versions which facilitate their integration in a virtually limitless number of system solutions.

DC bus power supply versions

• AVy...DC and AVy...Slim-DC

The AVy...DC range has the same mechanical dimensions as the standard range, the only difference being that it does have an input rectifier bridge.

The AVy...Slim-DC range offers mechanical dimensions specifically designed for multi-drive system solutions in cabinets.

Versions for external heat sink assembly

• AVy...EH

The external heat sink assembly option, already available with the standard range up to 15kW (20Hp) is now extended to AVy...EH models up to a rating of 55kW.

This type of assembly guarantees the heat sink IP54 protection across the whole range.

Liquid cooling versions

• AVy...WH

The AVy...WH versions are specially designed for liquid cooling systems.

In the case of ratings from 75kW and above, it is possible to integrate dynamic braking resistors with the same type of cooling.

Introduzione

Gli inverter della serie ARTDrive - AVy sono disponibili con una serie di versioni speciali, che ne consentono l'integrazione in soluzioni sistemiche praticamente illimitate.

Versioni per alimentazione da DC bus

• AVy...DC ed AVy...Slim-DC

La linea AVy...DC, mantiene le stesse dimensioni meccaniche della linea standard e si differenzia da questa esclusivamente per l'assenza del ponte raddrizzatore in ingresso.

La linea AVy...Slim-DC, propone dimensioni meccaniche espressamente concepite per soluzioni sistemiche multidrive in quadro elettrico.

Versioni per montaggio dissipatore esterno

• AVy...EH

La possibilità di montaggio esterno del dissipatore, già disponibile sulla linea standard fino al 15kW (20Hp), viene esteso con i modelli AVy...EH fino alla potenza da 55kW.

Tale tipologia di montaggio garantisce il grado di protezione IP54 del dissipatore, su tutta la gamma.

Versioni per raffreddamento a liquido

• AVy...WH

Le versioni AVy...WH sono dedicati a sistemi di raffreddamento a liquido.

Per potenze da 75kW o superiori, è disponibile l'integrazione di resistenze di frenatura dinamica con la stessa tipologia di raffreddamento.

Introduction

Les variateurs de la série ARTDrive - AVy sont disponibles avec une série de versions spéciales, qui en permettent l'intégration dans des solutions d'installation pratiquement illimitées.

Versions pour alimentation par DC bus

• AVy...DC et AVy...Slim-DC

La ligne AVy...DC, conserve les mêmes dimensions mécaniques que la ligne standard et se caractérise par rapport à cette dernière exclusivement par l'absence du pont redresseur à l'entrée.

La ligne AVy...Slim-DC, propose des dimensions mécaniques conçues spécialement pour les solutions d'installation multidrive en armoire électrique.

Versions pour le montage d'un dissipateur extérieur

• AVy...EH

La possibilité du montage extérieur du dissipateur, est déjà disponible sur la ligne standard jusqu'à 15kW (20Hp) et est étendue aux modèles AVy...EH jusqu'à la puissance de 55kW.

Ce type de montage garantit le degré de protection IP54 pour le dissipateur, sur toute la gamme.

Version pour refroidissement à liquide

• AVy...WH

Les versions AVy...WH sont réservées pour les systèmes de refroidissement par liquide.

Pour les puissances de 75kW ou supérieures, l'intégration de résistances de freinage dynamique est disponible avec le même type de refroidissement.

Einleitung

Die Frequenzumrichter der Serie ARTDrive - AVy sind in einer Reihe von Sonderausführungen erhältlich. Dadurch ist der Einbau in praktisch unbeschränkte Systemlösungen möglich.

Ausführungen für DC Bus-Versorgung

• AVy...DC und AVy...Slim-DC

Bei der Serie AVy...DC wurden die gleichen mechanischen Abmessungen wie bei der Standardserie beibehalten, von der sie sich lediglich dadurch unterscheidet, dass im Eingang keine Gleichrichterbrücke vorhanden ist.

Die Serie AVy...Slim-DC bietet mechanische Abmessungen, die ausdrücklich für Multidrive-Systeme auf elektrischer Schalttafel konzipiert wurden.

Ausführungen mit externer Kühlkörpermontage

• AVy...EH

Die Möglichkeit der externen Kühlkörpermontage, die bereits für die Standardserie bis 15 kW (20 Hp) erhältlich ist, wird mit den Modellen AVy...EH bis zu einer Leistung von 55 kW ausgedehnt.

Diese Montageart gewährleistet für die gesamte Produktpalette Schutzgrad IP54 für den Kühlkörper.

Ausführungen mit Flüssigkühlung

• AVy...WH

Die Ausführungen AVy...WH sind für Systeme mit Flüssigkühlung bestimmt.

Für Leistungen von 75 kW oder höher ist der Einbau dynamischer Bremswiderstände mit der gleichen Kühlungsart möglich.

Introducción

Los inversores de la serie ARTDrive - AVy están disponibles con una serie de versiones especiales, que permiten la integración en soluciones de sistemas prácticamente ilimitadas.

Versiones para alimentación del DC bus

• AVy...DC y AVy...Slim-DC

La línea AVy...DC, mantiene las mismas dimensiones mecánicas de la línea estándar y se diferencia de ésta exclusivamente en la ausencia del puente rectificador de entrada.

La línea AVy...Slim-DC, propone unas dimensiones mecánicas expresamente concebidas para soluciones de sistema multidrive en cuadro eléctrico.

Versiones para montaje de disipador externo

• AVy...EH

La posibilidad de montaje externo del disipador, ya disponible en la línea estándar hasta 15kW (20CV), viene incluido con los modelos AVy...EH hasta potencias de 55kW.

Esta tipología de montaje garantiza el grado de protección IP54 del disipador, en toda la gama.

Versiones con refrigeración líquida

• AVy...WH

Las versiones AVy...WH están dedicadas a los sistemas de refrigeración líquida.

Para potencias de 75kW o superiores, está disponible la integración de la resistencia de frenado dinámico con la misma tecnología de refrigeración.

General Features

Identification Code

Codice di Identificazione
Code d'Identification
Identifikationscode
Siglas Identificación Producto

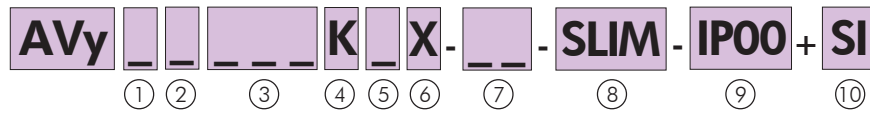

AVy	ARTDrive , Inverter	ARTDrive, Inverter	ARTDrive , Variateur	ARTDrive , Frequenzumrichter	ARTDrive , Inverter
①	Enclosure dimension identification	Identificazione della dimensione	Taille du boîtier	Versorgung Baugröße	Identificación de las dimensiones
②	[blank] = Standard version [S] = Slim version (compact)	[vuoto] = Versione standard [S] = versione Slim (compatta)	[vide] = version standard [S] = version Slim (compacte)	[leer] = Standardausführung [S] = Slim-Ausführung (kompakt)	[vacío] = versión estándar [S] = versiones Slim (compacta)
③	Inverter rated output power I.e.: 22 = 22kW	Potenza nominale in uscita Es.: 22 = 22kW	Puissance nominale de sortie Es.: 22 = 22kW	Ausgangsnennleistung z.B.: 22 = 22kW	Potencia nominal de salida Es.: 22 = 22kW
④	K = Programming keypad KBS	K = Tastierino di programmazione KBS	K = Clavier de programmation KBS	K = Programmierungs-Bedieneinheit KBS.	K = Teclado de programación KBS
⑤	X = Without integrated braking circuit B = with integrated braking circuit	X = Senza unità di frenatura interna B = con unità di frenatura interna	X = Sans unité de freinage interne B = Avec unité de freinage interne	X = Ohne Bremskreis. B = Integrierter Bremskreis.	X = Suministro sin unidad de frenado integrada B = suministro con unidad de frenado integrada
⑥	X = Standard software	X = Software standard	X = Logiciel standard	X = Standardsoftware.	X = Software estándar
⑦	- DC = DC supply - EH = Version with external heat sink - WH = Version with water-cooled heat sink	- DC = Alimentazione in DC - EH = Versione con dissipatore esterno - WH = Versione con dissipatore raffreddato ad acqua	- DC = Alimentation en courant continu. - EH = Version avec dissipateur extérieur. - WH = Version avec dissipateur refroidi à l'eau	- DC = DC-Versorgung - EH = Ausführung mit externem Kühlkörper - WH = Ausführung mit wassergekühltem Kühlkörper	- DC = Alimentación en DC - EH = Versiones con disipador externo - WH = Versiones con disipador refrigerado por agua.
⑧	- SLIM = Slim version (Ovld 150%) - SLIM-LD = Slim version (Low Duty: Ovld 110%)	- SLIM = versione Slim (Ovld 150%) - SLIM-LD = versione Slim (Low Duty: Ovld 110%)	- SLIM = version Slim (Ovld 150%) - SLIM-LD = version Slim (Low Duty: Ovld 110%)	- SLIM = Slim-Ausführung (Ovld 150%) - SLIM-LD = Slim-Ausführung (Low Duty: Ovld 110%)	- SLIM = versiones Slim (Ovld 150%) - SLIM-LD = versiones Slim (Low Duty: Ovld 110%)
⑨	[IPOO] = open frame	[IPOO] = a giorno	[IPOO] = à jour	[IPOO] = Freiluftausführung	[IPOO] = por día
⑩	[SI] = Safety card included	[SI] = Inclusa scheda Safety	[SI] = Carte Safety comprise	[SI] = Integrierter Safety	[SI] = Inclusa la placa Safety

 General Features

AVy...DC range

- Rectified voltage supply up to 480 Vac + 10%
- Motor ratings from 22kW (25Hp) to 315kW (450Hp)

AVy.Slim...-DC range

- Rectified voltage supply up to 480 Vac + 10%
- Motor ratings from 55kW (60Hp) to 132kW (150Hp)

AVy...-EH range

- 3-phase power supply: 230Vac -15% ... 480Vac +10%, 50/60Hz
- Motor ratings from 22kW (25Hp) to 55kW (60Hp)

AVy...-WH range

- 3-phase power supply: 230Vac -15% ... 480Vac +10%, 50/60Hz
- Motor ratings from 11kW (15Hp) to 132kW (150Hp)

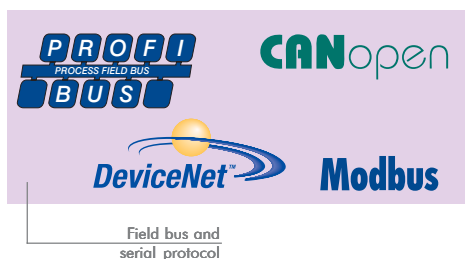

Standards and Marks

- CE:** complies with the EEC directive concerning low voltage equipment.
- UL, cUL:** complies with directives for the American and Canadian market (AVy...-DC range only).
- EMC:** complies with the EEC directive - EN 61800-3:2004 concerning electromagnetic compatibility with the use of optional filters.



Control modes

- Flux Vector control with encoder feedback
 - sinusoidal encoder (speed accuracy: 0,01%)
 - digital encoder (speed accuracy: 0,02%)
- Flux Vector control without encoder feedback (sensorless) (speed accuracy: 0.1% above 100rpm, 0.2% below 100rpm)
- V/f scalar control (speed accuracy varies with motor slip)

Main control and regulation functions

- Output frequency:
 - 400Hz for control with encoder feedback
 - 200Hz for sensorless control
- Offline self-tuning: for speed-current-flux loops and identifying motor data (possible with motor idle or rotating)
- Online self-tuning: compensation for motor parameters according to temperature variations
- Torque control: with built-in OR function for gradual switching between the speed and torque controllers
- Instant overload at 200%
- Overload capacity compliant with IEC 146 Class 1 and Class 2 (see the tables later on for more details)
- I²t thermal protection for motor and drive
- Multi-speed function (with 7 programmable speeds)
- 5 independent, programmable ramps (linear and S-curve)
- Motor potentiometer function
- Motor "auto-capture" function
- Droop function
- Dual motor management
- PID function block
- Mains loss detection with controlled stop and/or power optimisation
- Virtual or remote I/O management

Standard supply configuration

- LCD programming keypad or LED diagnostics module
- Integrated RS485 serial connection (ModBus RTU protocol)
- Standard inputs/outputs:
 - 3 programmable differential analogue inputs (voltage/current)
 - 2 programmable analogue outputs
 - 8 digital inputs: 4 non-programmable + 4 programmable
 - 2 programmable digital outputs
 - 2 programmable relay outputs
- Integrated encoder input: sinusoidal 1Vpp (+5V) and digital TTL (+5V)
- EasyDrive, an advanced configuration software application for PC, including
 - programming inverter function blocks in a graphical environment
 - user file archiving
 - guided programming procedure for commissioning using a Wizard function
 - graphic display of variables via a "Trend recorder" oscilloscope function
- Interfacing with fieldbus: ProfiBus, CANopen and DeviceNet (with optional card)

Accessories (optional)

- Dedicated EMC filters (compliant with EEC Directive - EN 61800-3:2004)
- Braking resistors (standardised for the whole range)
- Input and output inductors (standardised for the whole range)
- Programming remote keypad kit

Environmental conditions

- Housing:** IP20 in cabinet as standard
for IP54 inverter to be mounted in a cabinet with an external heat sink: ...-EH and ...-WH ranges
- Operating temperature:** from 0°C to 40 °C, from + 40 °C to +50 °C with derating.

NOTE! The AVy...WH range utilises a cooling circuit from the water-cooled heat sink, whose liquid input temperature range must be between 20°C and 30°C. To avoid problems with condensation dripping from the heat sink, a conservative Molier diagram dew point of 40°C with a hysteresis of 3°C has been selected.

- Storage temperature:** -25°C...+55°C (Class 1K4 – EN50178)
- Humidity:** from 5% to 85%, relative humidity (without condensation) or formation of ice (Class 3K3 under EN50178)
- Altitude:** up to 2000 metres above sea level. Above 1000 metres, that the current is reduced by 1.2% for each additional 100 metres in altitude.

General Features

Caratteristiche Generali

Linea "AVy...DC"

- Alimentazione da tensioni raddrizzate fino a 480Vac +10%
- Potenze motore da 22kW (25Hp) a 315kW (450Hp)

Linea "AVy.Slim...-DC"

- Alimentazione da tensioni raddrizzate fino a 480Vac +10%
- Potenze motore da 55kW (60Hp) a 132kW (150Hp)

Linea "AVy...-EH"

- Alimentazione trifase: 230Vac -15% ... 480Vac +10%, 50/60Hz
- Potenze motore da 22kW (25Hp) a 55kW (60Hp)

Linea "AVy...-WH"

- Alimentazione trifase: 230Vac -15% ... 480Vac +10%, 50/60Hz
- Potenze motore da 11kW (15Hp) a 132kW (150Hp)

Modalità di controllo

- Controllo Vettoriale di Flusso con retroazione da encoder:
 - encoder sinusoidale (precisione di velocità: 0,01%)
 - encoder digitale (precisione di velocità: 0,02%)
- Controllo Vettoriale di Flusso senza retroazione da encoder (Sensorless) (precisione di velocità: 0,1% sopra i 100rpm, 0,2% sotto i 100rpm)
- Controllo scalare V/f (precisione di velocità in funzione dello scorrimento del motore)

Funzioni di controllo e regolazione principali

- Frequenza di uscita:
 - 400Hz per controllo con retroazione da encoder
 - 200Hz in controllo Sensorless
- Autotaratura off-line: dei regolatori di velocità-corrente-flusso ed identificazione dati motore (possibile con motore fermo od in rotazione)
- Autotaratura on-line: compensazione dei parametri motore in funzione delle variazioni di temperatura
- Controllo di coppia: con funzione OR built-in, per commutazione graduale tra regolatore di velocità e regolatore di coppia
- Sovraccarico istantaneo al 200 %
- Capacità sovraccarico secondo IEC 146 Classe 1 e Classe 2 (per maggiori dettagli vedere tabelle seguenti)
- Protezione termica I²t per motore e Drive
- Funzione Multivelocità (7 programmabili)
- 5 rampe indipendenti e programmabili (lineare ed a S)
- Funzione Motopotenziometro
- Funzione di riaggancio al volo motore
- Droop Function
- Gestione doppio motore
- Blocco funzione PID
- Gestione in caso di mancanza rete mediante: arresto controllato o/e ottimizzazione dell'energia
- Gestione I/O virtuali o remote.

Configurazione di Fornitura Standard

- Tastiera di programmazione LCD o modulo di diagnostica a led
- Linea seriale RS485 integrata (protocollo ModBus RTU)
- Ingressi/Uscite standard:
 - 3 ingressi analogici differenziali programmabili (Tensione/Corrente)
 - 2 uscite analogiche programmabili
 - 8 ingressi digitali: 4 non programmabili + 4 programmabili
 - 2 uscite digitali programmabili
 - 2 uscite a relè programmabili
- Ingresso encoder integrato: sinusoidale 1Vpp (+5V) e digitale TTL (+5V)
- Software di configurazione evoluto per PC "EasyDrive" incluso:
 - programmazione in ambiente grafico dei blocchi funzione dell'inverter
 - archiviazione file utente
 - procedura di programmazione guidata per la messa in servizio mediante "Wizard"
 - visualizzazione grafica delle variabili e delle funzioni mediante "Trend recorder"
- Interfacciamento con bus di campo : ProfiBus, CANopen e DeviceNet (con scheda opzionale)

Accessori (Opzionali)

- Filtri EMC dedicati (in conformità alla direttiva CEE - EN61800-3)
- Resistenze di frenatura (normalizzate per l'intera gamma)
- Induttanze d'ingresso ed uscita (normalizzate per l'intera gamma)
- Kit per remotaggio tastiera di programmazione

Condizioni Ambientali

- Alloggiamento:** IP20 in quadro standard
per IP54 inverter predisposto per il montaggio in quadro con dissipatore esterno: linea "...-EH" e "...-WH"
- Temperatura di esercizio:** da 0°C a 40 °C , da + 40 °C a +50 °C con derating.

Nota! La linea "AVy...WH" utilizza un circuito di raffreddamento del dissipatore ad acqua, per il quale la temperatura di ingresso del liquido dovrà risultare non inferiore a 20°C e preferibilmente non superiore a 30°C.
Per evitare problemi di gocciolamento del dissipatore dovuti al fenomeno della condensazione, è stato scelto un punto della caratteristica Molier "dew-point" conservativo di 40°C con isteresi di 3°C.

- Temperatura di immagazzinaggio:** -25°C...+55°C (Classe 1K4 - EN50178)
- Umidità:** da 5% a 85%, umidità relativa (senza condensa) o formazione di ghiaccio (classe 3K3 in accordo a EN50178)
- Altitudine:** fino a 2000 metri s.l.m.; oltre 1000 metri, la corrente deve essere ridotta del 1,2% ogni 100 metri di incremento.



Norme e Marchi

- CE:** conforme alla direttiva CEE sugli apparecchi a bassa tensione.
- UL, cUL:** conforme alle direttive per il mercato Americano e Canadese (solo linea AVy...-DC).
- EMC:** conforme alla direttiva CEE - EN 61800-3, sulla compatibilità elettromagnetica con l'impiego dei filtri opzionali.



 **Caractéristiques Générales**

<p>Ligne "AVy...DC"</p> <ul style="list-style-type: none"> - Alimentation par des tensions redressées jusqu'à 480Vca +10% - Puissances du moteur de 22kW (25Hp) à 315kW (450Hp)
<p>Ligne "AVy.Slim...-DC"</p> <ul style="list-style-type: none"> - Alimentation par des tensions redressées jusqu'à 480Vca +10% - Puissances du moteur de 55kW (60Hp) à 132kW (150Hp)
<p>Ligne "AVy...-EH"</p> <ul style="list-style-type: none"> - Alimentation triphasée : 230Vca - 15% - 480Vca +10%, 50/60Hz - Puissances du moteur de 22kW (25Hp) à 55kW (60Hp)
<p>Ligne "AVy...-WH"</p> <ul style="list-style-type: none"> - Alimentation triphasée : 230Vca - 15% - 480Vca +10%, 50/60Hz - Puissances du moteur de 11kW (15Hp) à 132kW (150Hp)

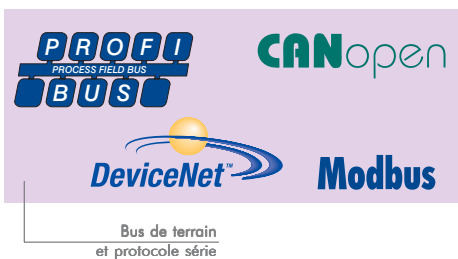

Normes et marques

- CE:** conformes à la directive CEE sur les appareils en basse tension.
- UL, cUL:** conformes aux directives pour le marché Américain et Canadien (seulement ligne AVy...-DC).
- EMC:** conformes à la directive CEE - EN 61800-3:2004, concernant la compatibilité électromagnétique avec l'utilisation des filtres en option.



Mode de contrôle

- Contrôle Vectoriel du Flux avec rétroaction par codeur :
 - codeur sinusoïdal (précision de la vitesse : 0,01%)
 - codeur digital (précision de la vitesse : 0,02%)
- Contrôle Vectoriel du flux sans rétroaction par codeur (Sensorless) (précision de la vitesse : 0,1% au-dessus de 100 t/mn, 0,2% au-dessous de 100 t/mn)
- Contrôle progressif V/f (précision de la vitesse en fonction du glissement du moteur)

Fonctions principales de contrôle et de régulation

- Fréquence de sortie :
 - 400Hz pour le contrôle avec rétroaction par codeur
 - 200Hz en contrôle Sensorless
- Calibrage automatique off-line : des régulateurs de vitesse-courant-flux et identification des données moteur (possible avec moteur à l'arrêt ou moteur en phase de rotation)
- Calibrage automatique on-line : compensation des paramètres moteur en fonction des variations de température
- Contrôle du couple : à fonction OR built-in, pour commutation graduelle entre régulateur de vitesse et régulateur de couple
- Surcharge instantanée à 200 %
- Capacité de surcharge selon CIE 146 Classe 1 et Classe 2 (pour de plus amples informations, voir les tableaux suivants)
- Protection thermique I²t pour moteur et Drive
- Fonction multivitesse (7 programmables)
- 5 rampes indépendantes et programmables (linéaire et en S)
- Fonction Motopotentiomètre
- Fonction de redémarrage au vol du moteur
- Droop Function
- Gestion double moteur
- Bloc fonction PID
- Gestion en cas de coupure de secteur par : arrêt contrôlé et/ou optimisation de l'énergie
- Gestion E/S virtuelles ou à distance.

Configuration en fourniture standard

- Clavier de programmation LCD ou module de diagnostic à led
- Ligne série RS485 intégrée (protocole Modbus RTU)
- Entrées/Sorties standards :
 - 3 entrées analogiques différentielles programmables (Tension/Courant)
 - 2 sorties analogiques programmables
 - 8 entrées digitales : 4 non programmables + 4 programmables
 - 2 sorties numériques programmables
 - 2 sorties à relais programmables
- Entrée codeur intégré : sinusoïdal 1Vpp (+5V) et digital TTL (+5V)
- Logiciel de configuration de pointe pour PC "EasyDrive" compris :
 - programmation dans un milieu graphique des blocs fonction du variateur
 - archivage des fichiers utilisateur
 - procédure de programmation guidée pour la mise en service à l'aide de la "Wizard"
 - visualisation graphique des variables et des fonctions à l'aide de "Trend recorder"
- Interface par bus de terrain : ProfiBus, CANOpen et DeviceNet (avec carte optionnelle)

Accessoires (Options)

- Filtres EMC spéciaux (conformes à la directive CEE - EN 61800-3:2004)
- Résistances de freinage (normalisées pour toute la gamme)
- Inductances d'entrée et de sortie (normalisées pour toute la gamme)
- Kit pour installation à distance de la console de programmation

Conditions d'environnement

- Logement :** IP20 dans armoire standard pour IP54 variateur prévu pour le montage en armoire avec dissipateur extérieur : ligne "...-EH" et "...-WH
- Température de service :** de 0°C à 40 °C, de + 40 °C à +50 °C avec déclassement.

Remarque ! La ligne "AVy...WH" utilise un circuit de refroidissement du dissipateur à l'eau, pour lequel la température d'entrée du liquide ne doit pas être inférieure à 20°C et de préférence pas supérieure à 30°C. Pour éviter des problèmes de gouttelement du dissipateur, à cause du phénomène de la condensation, on a choisi un point de la caractéristique Molier "dew-point" conservateur de 40°C avec des hystérésis de 3°C.

- Température de stockage :** -25°C...+55°C (Classe 1K4 - EN50178)
- Humidité :** de 5% à 85%, humidité relative (sans condensation) ou formation de glace (classe 3K3 conformément à la norme EN50178)
- Altitude :** jusqu'à 2000 mètres au-dessus du niveau de la mer; au-delà de 1000 mètres, le courant doit être diminué de 1,2% tous les 100 mètres supplémentaires.

Allgemeine Merkmale

<p>Serie "AVy...-DC"</p> <ul style="list-style-type: none"> - Versorgung durch gleichgerichtete Spannungen bis 480 V_{AC} +10 % - Motorleistungen von 22 kW (25 Hp) bis 315 kW (450 Hp)
<p>Serie "AVy.Slim...-DC"</p> <ul style="list-style-type: none"> - Versorgung durch gleichgerichtete Spannungen bis 480 V_{AC} +10 % - Motorleistungen von 55 kW (60 Hp) bis 132 kW (150 Hp)
<p>Serie "AVy...-EH"</p> <ul style="list-style-type: none"> - Dreiphasige Versorgung: 230 V_{AC} -15 % ... 480 V_{AC} +10 %, 50/60 Hz - Motorleistungen von 22 kW (25 Hp) bis 55 kW (60 Hp)
<p>Serie "AVy...-WH"</p> <ul style="list-style-type: none"> - Dreiphasige Versorgung: 230 V_{AC} -15 % ... 480 V_{AC} +10 %, 50/60 Hz - Motorleistungen von 11 kW (15 Hp) bis 132 kW (150 Hp)

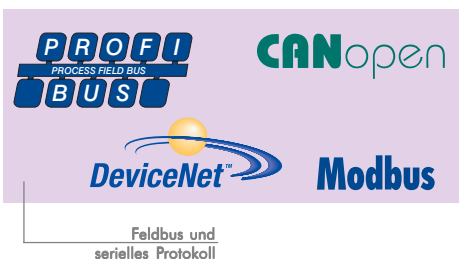

Normen und Marken

CE:	entspricht der EG-Richtlinie über Geräte mit Niederspannung.
UL, cUL:	entspricht den Richtlinien für den amerikanischen und kanadischen Markt (nur für Serie AVy...-DC).
EMC:	entspricht der EG-Richtlinie – EN 61800-3:2004 über die elektromagnetische Verträglichkeit mit dem Einsatz optionaler Filter.



Regelungsarten

- Vektorielle Flussregelung mit Encoderrückführung:
 - Sinusencoder (Drehzahlgenauigkeit: 0,01 %)
 - Digitalencoder (Drehzahlgenauigkeit: 0,02 %)
- Vektorielle Flussregelung ohne Encoderrückführung (Sensorless) (Drehzahlgenauigkeit: 0,1 % über 100 min⁻¹, 0,2 % unter 100 min⁻¹)
- Skalare U/f-Regelung (Drehzahlgenauigkeit in Funktion des Motorschlupfs)

Wichtigste Steuer- und Regelfunktionen

- Ausgangsfrequenz:
 - 400 Hz für Steuerung mit Encoderrückführung
 - 200 Hz bei Sensorless-Steuerung
- Inbetriebnahmefunktion: Adaption der Drehzahl-Strom-Flussregler und Motordatenidentifizierung (möglich bei still stehendem oder drehendem Motor)
- Online-Adaption: Anpassung der Motorparameter als Funktion der Temperaturänderungen
- Drehmomentregelung: mit eingebauter OR-Funktion für die schrittweise Umschaltung zwischen Drehzahlregler und Drehmomentregler
- Augenblickliche Überlast von 200 %
- Überlastkapazität gemäß IEC 146 Klasse 1 und Klasse 2 (für nähere Details siehe folgende Tabellen)
- Wärmeschutz I²t für Motor und Antrieb
- 7 programmierbare Drehzahlen
- 5 unabhängige, programmierbare Rampen (linear und s-förmig)
- Funktion Motorpotentiometer
- Aufschalten auf drehenden Motor
- Lastaufteilung bei mechanisch gekoppelten Motoren
- 2 Motorparametersätze
- zusätzlicher, frei programmierbarer PID-Regler
- Verhalten bei Netzausfall programmierbar: gesteuertes Anhalten und/oder Energieoptimierung.
- Einbindung virtueller oder entfernt liegender I/O (Feldbus)

Konfiguration Standardlieferung

- LCD-Programmierbedieneinheit oder LED-Diagnosemodul
- Integrierte serielle RS485 Schnittstelle (ModBus RTU Protokoll)
- Standardeingänge/-ausgänge:
 - 3 programmierbare Differential-Analogaingänge (Spannung/Strom)
 - 2 programmierbare Analogausgänge
 - 8 Digitaleingänge: 4 nicht programmierbare + 4 programmierbare
 - 2 programmierbare Digitalausgänge
 - 2 programmierbare Relaisausgänge
- Integrierter Encodeingang: Sinusencoder 1V_{pp} (+5 V) und Digitalencoder TTL (+5 V)
- Konfigurationssoftware für PC "EasyDrive" inklusive:
 - Programmierung der Frequenzrichter-Funktionsblöcke in graphischer Umgebung
 - Benutzerdateiarchivierung
 - Inbetriebnahme durch "Wizard"-Funktion
 - Graphische Anzeige der Variablen über die Oszilloskopfunktion "Trend recorder"
- Feldbusschnittstelle: ProfiBus, CANopen und DeviceNet (mit Optionskarte)

Zubehörteile (optional)

- spezielle EMV-Filter (gemäß EG Richtlinie – EN 61800-3:2004)
- Bremswiderstände (für die gesamte Produktpalette genormt)
- Ausgangsnetzdrosseln (für die gesamte Produktpalette genormt)
- Montagesatz für externe Installation der Programmier-Bedieneinheit

Umgebungsbedingungen

Gehäuse:	IP20 für Standard-Schalttafel für IP54, Frequenzrichter, der für die Schalttafelmontage mit externem Kühlkörper vorgesehen ist: Serie "...-EH" und "...-WH
Betriebstemperatur:	von 0° C bis 40° C , von + 40° C bis +50° C mit Leistungsreduktion.

Hinweis! Bei der Serie "AVy...EWH" wird für den Kühlkörper ein Wasserkühlkreis verwendet; die Eingangstemperatur der Flüssigkeit darf nicht unter 20° C und vorzugsweise nicht über 30° C liegen.
Um Probleme mit betauungsbedingtem Tropfen vom Kühlkörper zu vermeiden, wurde ein Punkt auf dem Mollier Taupunktendiagramm gewählt, der 40° C beibehält und eine Hysterese von 3° C aufweist.

Lagerungstemperatur:	-25° C...+55° C (Klasse 1K4 – EN50178)
Feuchtigkeit:	von 5 % bis 85 %, relative Feuchtigkeit (ohne Betauung) oder Eisbildung (Klasse 3K3 entsprechend EN50178)
Installationshöhe:	bis zu 2000 Metern ü.d.M.; über 1000 Metern, muss der Strom pro 100 Höhenmeter um 1,2 % verringert werden.

 Características Generales

<p>Linea "AVy...-DC"</p> <ul style="list-style-type: none"> - Alimentación de tensiones rectificadas hasta 480Vac +10% - Potencias de motores desde 22kW (25CV) hasta 315kW (450CV)
<p>Linea "AVy.Slim...-DC"</p> <ul style="list-style-type: none"> - Alimentación de tensiones rectificadas hasta 480Vac +10% - Potencias de motores desde 55kW (60CV) hasta 132kW (150CV)
<p>Linea "AVy...-EH"</p> <ul style="list-style-type: none"> - Alimentación trifásica: 230Vac -15% ... 480Vac +10%, 50/60Hz - Potencias de motores desde 22kW (25CV) hasta 55kW (60CV)
<p>Linea "AVy...-WH"</p> <ul style="list-style-type: none"> - Alimentación trifásica: 230Vac -15% ... 480Vac +10%, 50/60Hz - Potencias de motores desde 11kW (15CV) hasta 132kW (150CV)



Normas y marcas

- CE:** de acuerdo con la directiva CEE en los equipos de baja tensión
- UL, cUL:** en cumplimiento de las directivas para el mercado Americano y Canadiense (sólo línea AVy...-DC).
- EMC:** de acuerdo con la directiva CEE - EN 61800-3:2004, sobre la compatibilidad electromagnética con el empleo de filtros opcionales.



Modalidad de control

- Control vectorial de flujo con realimentación del encoder:
 - encoder sinusoidal (precisión de velocidad: 0,01%)
 - encoder sinusoidal (precisión de velocidad: 0,02%)
- Control vectorial de flujo sin realimentación de encoder (Sensorless) (precisión de velocidad: 0,1% por debajo de 100rpm, 0,2% por debajo de 100rpm)
- Control escalar V/f (precisión de velocidad en función del deslizamiento del motor)

Función de control y regulaciones principales

- Frecuencia de salida:
 - 400Hz por control con realimentación de encoder
 - 200Hz en control Sensorless
- Calibración automática off-line: de los reguladores de velocidad-intensidad-flujo e identificación de datos de los motores (posible con motores parados y en rotación)
- Calibración automática on-line: compensación de los parámetros de los motores en función de las variaciones de temperatura
- Control de par: con función OR integrada, por comunicación gradual de los reguladores de velocidad y de los reguladores de par
- Sobrecarga instantánea del 200 %
- Capacidad de sobrecarga según las directrices IEC 146 Clase 1 y Clase 2 (para mayores detalles consulte la tabla siguiente)
- Protección térmica I²t para motor y Drive
- Función multivelocidad (7 programaciones)
- 5 rampas independientes y programables (lineales y en S)
- Función Motopotenciómetro
- Función de reenganche del motor al vuelo
- Función Droop
- Gestión doble motor
- Bloqueo función PID
- Gestión en caso de fallo red mediante: parada controlada y/o optimización de la energía
- Gestiones de E/S virtuales o remotas.

Configuración de entrega estándar

- Teclado de programación LCD o módulo de diagnóstico por leds
- Línea serie RS485 integrada (protocolo Modbus RTU)
- Entradas/Salidas estándar:
 - 3 entradas analógicas diferenciales programables (Tensión/Intensidad)
 - 2 salidas analógicas programables
 - 8 entradas digitales: 4 no programables + 4 programables
 - 2 salidas digitales programables
 - 2 salidas de relé programables
- Entrada de encoder integrada: sinusoidal 1Vpp (+5V) y digital TTL (+5V)
- Software de configuración avanzado para PC "EasyDrive" incluido:
 - programación en entorno gráfico de los bloques de funciones del inverter
 - archivación de los archivos de salida
 - procedimiento de programación asistida para la puesta en servicio por medio de la función de asistente, "Wizard"
 - visualización gráfica de las variables y las funciones a través de "Trend recorder"
- Interfaz con bus de campo: Profibus, CANopen y DeviceNet (con tarjeta opcional)

Accesorios (Opcionales)

- Filtros EMC dedicados (según la normativa europea (CEE - EN 61800-3:2004)
- Resistencia de frenado (normalizada para toda la gama)
- Inductancia de entrada y salida (normalizada para toda la gama)
- Kit para teclado de programación remota

Condiciones ambientales

- Alojamiento:** IP20 en cuadro estándar para IP54 inverter preparado para el montaje en cuadro con disipador externo: línea "...-EH" e "...-WH
- Temperatura de ejercicio:** de 0°C a 40 °C , de + 40 °C a +50 °C con reducción.

iNota! La línea "AVy...EWH" utiliza un circuito de refrigeración del disipador por agua, por el que la temperatura de entrada del líquido deberá ser no inferior a 20°C y preferiblemente no superior a 30°C. Para evitar problemas de pérdidas del disipador debidas al fenómeno de la condensación, se ha seleccionado un punto con la característica Molier "dew-point" conservativo de 40°C con histéresis de 3°C.

- Temperatura de almacenamiento:** -25°C...+55°C (Clase 1K4 – EN50178)
- Humedad:** del 5% al 85%, humedad relativa (sin condensación) o formación de hielo (clase 3K3 en cumplimiento de la normativa EN50178)
- Altura:** hasta 2000 metros por encima del nivel del mar; para altitudes superiores 1000 m asegurarse de que la corriente se reduce un 1,2% por cada 100 metros de altura adicionales.

Scelta dell'Inverter
Sélection du Variateur
Wahl des Frequenzumrichters
Selección del Convertidor de
Frecuencia



Co-ordination of the nominal power rating for a motor with the type of inverter that is referred to in the table will require use of motors that operate at a voltage corresponding to the nominal values of the power supply network.
For motors that operate at other voltages, the type of inverter that is selected will depend on the nominal current of the motor to be controlled.

The combination put forward in the table, therefore reflects, as a function of the power supply voltage, the value of current the drive is able to supply operating conditions (IEC146 Class 1) and under overload conditions (IEC146 Class 2), i.e.:

IEC 146 Class 1: continuous operation with maximum overload = $I_{2N} \times 1.36$ for 60 seconds (*)
IEC 146 Class 2: continuous operation at 0.91% of I_{2N} with maximum overload = $0.91 I_{2N} \times 1.5$ for 60 seconds every 5 minutes

(*) AVy93150/93550/94000-...-SLIM-LD-.. = $I_{2N} \times 1.10$ for 60 seconds

Analogous dimensioning criteria are applicable for any operations to which additional downgrading factors are applicable:

KV Power supply voltage
KT Ambient temperature
KF Switching frequency

Data:	Output	Input
AVy...-DC & AVy.S...-DC	table on page 50	table on page 51
AVy...-EH	table on page 52	table on page 53
AVy...-WH	table on page 54	table on page 55



Il coordinamento delle potenze nominali del motore con il tipo di inverter riportato in tabella, prevede l'impiego di motori con tensione nominale corrispondente alla nominale della rete di alimentazione.

Per motori con tensione differente, la scelta dell'inverter dovrà essere effettuata in base alla corrente nominale del motore stesso.

L'abbinamento suggerito in tabella, riporta quindi in funzione della tensione di alimentazione, il valore di corrente erogabile dal drive in condizioni di funzionamento continuativo (IEC146 Classe1) ed in condizioni di sovraccarico (IEC146 Classe 2), ovvero:

IEC 146 Classe 1: servizio continuativo con sovraccarico max = $I_{2N} \times 1,36$ per 60 secondi (*)
IEC 146 Classe 2: servizio continuativo allo 0,91% di I_{2N} con sovraccarico max = $0,91 I_{2N} \times 1,5$ per 60 secondi ogni 5 minuti

(*) AVy93150/93550/94000-...-SLIM-LD-.. = $I_{2N} \times 1.10$ per 60 secondi

Criteri di dimensionamento analoghi, vengono applicati per operazioni con fattori di declassamento addizionali:

KV Tensione di alimentazione
KT Temperatura ambiente
KF Frequenza di switching

Dati:	d'Uscita	d'Ingresso
AVy...-DC & AVy.S...-DC	vedere pagina 50	vedere pagina 51
AVy...-EH	vedere pagina 52	vedere pagina 53
AVy...-WH	vedere pagina 54	vedere pagina 55



La coordination des puissances nominales du moteur avec le type du variateur figurant dans le tableau, prévoit l'utilisation de moteurs ayant une tension nominale correspondant à la tension nominale du réseau d'alimentation.

Pour les moteurs ayant une tension différente, la sélection du variateur doit être effectuée en fonction du courant nominal du moteur.

La sélection suggérée dans le tableau, indique, en fonction de la tension d'alimentation, la valeur du courant fourni par le variateur dans des conditions d'un service continu (IEC146 Classe1) et dans des conditions de surcharge (IEC146 Classe 2), c'est-à-dire :

IEC 146 Classe 1: service continu avec une surcharge maxi = $I_{2N} \times 1,36$ pendant 60 secondes (*)
IEC 146 Classe 2: service continu à 0,91% de I_{2N} avec une surcharge maxi = $0,91 I_{2N} \times 1,5$ pendant 60 secondes toutes les 5 minutes

(*) AVy93150/93550/94000-...-SLIM-LD-.. = $I_{2N} \times 1.10$ pendant 60 secondes

Des critères de dimensionnement analogues sont appliqués pour les opérations avec des facteurs de déclassement supplémentaires :

KV Tension d'alimentation
KT Température ambiante
KF Fréquence de commutation

Caractéristiques:	Sortie	Entrée
AVy...-DC & AVy.S...-DC	tableau page 50	tableau page 51
AVy...-EH	tableau page 52	tableau page 53
AVy...-WH	tableau page 54	tableau page 55

 Die angegebene Motornennleistung gilt bei Übereinstimmung der Motornennspannung mit der Netz-Nennspannung.
Für Motoren mit einer anderen Spannung muss der Frequenzrichter ausgehend vom Motor-Nennstrom gewählt werden.

Die laut Tabelle empfohlene Kombination zeigt daher den vom Antrieb je nach Versorgungsspannung lieferbaren Stromwert, unter kontinuierlichen Betriebsbedingungen (IEC146 Klasse1) und unter Überlastbedingungen (IEC146 Klasse 2):

IEC 146 Klasse 1: kontinuierlicher Betrieb mit max. Überlast = $I_{2N} \times 1,36$ für 60 Sekunden (*)
IEC 146 Klasse 2: kontinuierlicher Betrieb mit 0,91% von I_{2N} mit max. Überlast = $0,91 I_{2N} \times 1,5$ für 60 Sekunden alle 5 Minuten

(*) AVy93150/93550/94000-...-SLIM-LD-... = $I_{2N} \times 1.10$ für 60 Sekunden

Weitere Bemessungskriterien werden für den Betrieb mit zusätzlichen Anpassungsfaktoren angewendet:

KV Versorgungsspannung
KT Umgebungstemperatur
KF Schaltfrequenz

	Ausgangsdaten	Eingangsdaten
AVy...-DC & AVy.S...-DC	Tabelle auf Seite 50	Tabelle auf Seite 51
AVy...-EH	Tabelle auf Seite 52	Tabelle auf Seite 53
AVy...-WH	Tabelle auf Seite 54	Tabelle auf Seite 55

 La coordinación de la potencia nominal del motor con el tipo de inverter al que se refiere la tabla, requerirá el uso de motores que operen con una tensión nominal correspondiente a los valores nominales del resto de alimentación.

Para motores que operen con otras tensiones, el tipo de inverter seleccionado, debería depender de la intensidad nominal del motor en cuestión

La combinación reflejada en la siguiente tabla refleja, en función de la tensión de alimentación, el valor de corriente que el equipo es capaz de suministrar bajo continuas condiciones de operación (IEC 146 Clase 1) y bajo condiciones de sobrecarga (IEC 146 Clase 2), por ejemplo:

IEC 146 Clase 1: operación continuada con sobrecarga máxima = $I_{2N} \times 1,36$ en 60 segundos (*)
IEC 146 Clase 2: operación continuada a 0,91% de I_{2N} con sobrecarga máxima = $0,91 I_{2N} \times 1,5$ en 60 segundos cada 5 minutos

(*) AVy93150/93550/94000-...-SLIM-LD-... = $I_{2N} \times 1.10$ en 60 segundos

Se aplica un criterio de dimensiones análogas aplicable en cada operación en la qual los factores degradantes sean aplicables:

KV Tensión de alimentación
KT Temperatura ambiente
KF Frecuencia de arranque

Data:	Output data	Input data
AVy...-DC & AVy.S...-DC	tabla en la página 50	tabla en la página 51
AVy...-EH	tabla en la página 52	tabla en la página 53
AVy...-WH	tabla en la página 54	tabla en la página 55

Inverter Selection

AVy...-DC, Output data

Dati in Uscita
Caractéristiques de Sortie

Ausgangsdaten
Datos de Salida

Drive Type	P _N mot (recommended motor output):										U ₂ Max output voltage	f _z Max output frequency	I _{2N} Rated output current :				f _{sw} switching frequency (Default)	f _{sw} switching frequency (Higher)	Derating factor:				
	Inverter Output (IEC 146 class 1), Continuous service (@ 400 VAC)		Inverter Output (IEC 146 class 2), 150% overload for 60s (@ 400 VAC)		f _{sw} =default; IEC 146 class 1		f _{sw} =default; IEC 146 class 2		f _{sw} =default; IEC 146 class 1				f _{sw} =default; IEC 146 class 2		f _{sw} =default; IEC 146 class 1				f _{sw} =default; IEC 146 class 2		Voltage Factor K _V at 460 VAC *	Temp. Factor K _T for ambient temperature	Switching frequency K _F
	@ U _{LN} =230 VAC ;	f _{sw} =default; IEC 146 class 1	@ U _{LN} =230 VAC ;	f _{sw} =default; IEC 146 class 2	@ U _{LN} =230 VAC ;	f _{sw} =default; IEC 146 class 1	@ U _{LN} =230 VAC ;	f _{sw} =default; IEC 146 class 2	@ U _{LN} =400 VAC ;	f _{sw} =default; IEC 146 class 1			@ U _{LN} =400 VAC ;	f _{sw} =default; IEC 146 class 2	@ U _{LN} =460 VAC ;	f _{sw} =default; IEC 146 class 1			@ U _{LN} =460 VAC ;	f _{sw} =default; IEC 146 class 2			
AVy...-DC	kVA	kVA	kW	kW	Hp	Hp	kW	kW	Hp	Hp	V	Hz	A	A	A	A	kHz	kHz	K _V	K _T	K _F		
4220	32	29	11	11	15	15	22	22	30	25	0.98 x U _{LN} (AC Input voltage)	500	47	43	40	36	8	16	0.8 @ 50°C (122°F)		0.7 for higher f _{sw}		
4300	42	38.2	18.5	15	25	20	30	30	40	30		500	63	58	54	50	8	16				0.87	
4370	55	50	22	18.5	30	25	37	37	50	40		500	79	72	68	62	8	16				0.87	
5450	64	58.3	22	22	30	30	45	45	60	50		200	93	85	81	74	4	8				0.87	
5550	79	72	30	30	40	40	55	55	75	60		200	114	104	99	90	4	8				0.87	
6750	98	89.2	37	37	50	50	75	75	100	75		200	142	129	124	112	4	8				0.87	
7900	128	116.5	55	45	75	60	90	90	125	100		200	185	169	160	146	4	8				0.87	
71100	145	132	55	55	75	75	110	90	150	125		200	210	191	183	166	4	8				0.87	
71320	173	157.5	75	55	100	75	132	110	150	150		200	250	227	217	198	4	8				0.87	
81600	224	204	90	90	100	100	160	160	200	200		200	324	295	282	256	4	-				0.87	

AVy...-DC-IP00 AVy...-DC-SLIM..	kVA	kVA	kW	kW	Hp	Hp	kW	kW	Hp	Hp	V	Hz	A	A	A	A	Hz	kHz	K _V	K _T	K _F
92500	335	303	-	-	-	-	250	250	350	300	0.98 x U _{LN} (AC Input voltage)	200	485	441	422	384	2000	-	0.87	0.8 @ 50°C (122°F)	-
93150	400	363	-	-	-	-	315	250	450	450		200	580	527	566	515	2000	-	0.97		
93550	450	405	-	-	-	-	355	-	500	-		200	650	-	585	-	2000	-	0.87		
94000	505	455	-	-	-	-	400	-	600	-		200	730	-	657	-	2000	-	0.87		

AVy.S...-DC	kVA	kVA	kW	kW	Hp	Hp	kW	kW	Hp	Hp	V	Hz	A	A	A	A	kHz	kHz	K _V	K _T	K _F
5S550	79	72	30	30	40	40	55	55	75	60	0.98 x U _{LN} (AC Input voltage)	200	114	104	99	90	4	8	0.87	0.8 @ 50°C (122°F)	0.7 for higher f _{sw}
6S750	98	89.2	37	37	50	50	75	75	100	75		200	142	129	124	112	4	8	0.87		
6S1100	145	132	55	55	75	75	110	90	150	125		200	210	191	183	166	2	8	0.87		
6S1320	173	157.5	75	55	100	75	132	110	150	150		200	250	227	217	198	2	8	0.87		

*: Data recorded for operating conditions at an ambient temperature of 40 °C.

*: Dati riportati per condizioni di funzionamento a temperatura ambiente 40°C.

*: Die angeführten Daten gelten unter Betriebsbedingungen bei einer

*: Données fournies pour des conditions de fonctionnement sous une température ambiante de 40°C.





*: Datos para condiciones de trabajo en una temperatura ambiente de 40°C.

AVy...-DC, Input data

Dati in Ingresso
Caractéristiques d'Entrée

Eingangsdaten
Datos de Entrada

Drive Type	U_{DCN} DC Input voltage	I_N DC Input current for continuous service @ 540 V _{DC}	Overtoltage threshold	Undervoltage threshold	Braking IGBT Unit, Standard internal (with external resistor) MAX braking torque
AVy...-DC	V _{DC}	A	V	V	%
4220	275 ... 750 V _{DC}	54	410 V _{DC} (for 230 V _{AC} mains) 800 V _{DC} (for 400 V _{AC} mains) 800 V _{DC} (for 460 V _{AC} mains)	230 V _{DC} (for 230 V _{AC} mains) 380 V _{DC} (for 400 V _{AC} mains) 415 V _{DC} (for 460 V _{AC} mains)	150 (2)
4300	275 ... 750 V _{DC}	76			150 (2)
4370	275 ... 750 V _{DC}	94			150 (2)
5450	275 ... 750 V _{DC}	115			150 (2)
5550	275 ... 750 V _{DC}	135			150 (2)
6750	275 ... 750 V _{DC}	170			(3)
7900	275 ... 750 V _{DC}	194			(3)
71100	275 ... 750 V _{DC}	265			(3)
71320	275 ... 750 V _{DC}	303			(3)
81600	275 ... 750 V _{DC}	378			(3)
AVy...-DC-IP00	V _{DC}	A	V	V	%
92500	275 ... 750 V _{DC}	635	800 V _{DC} (for 400 V _{AC} mains)	380 V _{DC} (for 400 V _{AC} mains)	(3)
93150	480 ... 750 V _{DC}	735	800 V _{DC} (for 460 V _{AC} mains)	415 V _{DC} (for 460 V _{AC} mains)	(3)
AVy...-DC-SLIM-IP00	V _{DC}	A	V	V	%
92500	275 ... 750 V _{DC}	635	800 V _{DC} (for 400 V _{AC} mains) 800 V _{DC} (for 460 V _{AC} mains)	380 V _{DC} (for 400 V _{AC} mains) 415 V _{DC} (for 460 V _{AC} mains)	(3)
93150	480 ... 750 V _{DC}	735			(3)
93550	480 ... 750 V _{DC}	800			(3)
94000	480 ... 750 V _{DC}	900			(3)

-  (2): Optional internal braking unit (with external resistor). (3): External braking unit (optional).
-  (2): Unità di frenatura interna opzionale (con resistenza esterna). (3): Unità di frenatura esterna (opzionale).
-  (2): Unité de freinage interne en option (avec résistance externe). (3): Unité de freinage extérieure (option).
-  (2): Optionale interne Bremsseinheit (mit externem Widerstand). (3): Externe Bremsseinheit (optional).
-  (2): Unidad de frenado interna opcional (con resistencia externa). (3): Unidad de frenado externo (opcional).

AVy...-EH, Output data

Dati in Ingresso
Caractéristiques d'Entrée

Eingangsdaten
Datos de Entrada

Drive Type	P _n mot (recommended motor output):										U ₂ Max output voltage	I _{2N} Rated output current :				f _{sw} switching frequency (Default)	f _{sw} switching frequency (Higher)	Derating factor:								
	Inverter Output (IEC 146 class 1), Continuous service (@ 400 V _{AC})		Inverter Output (IEC 146 class 2), 150% overload for 60s (@ 400 V _{AC})		@ U _{LN} = 230 V _{AC} ; f _{sw} = default; IEC 146 class 1		@ U _{LN} = 230 V _{AC} ; f _{sw} = default; IEC 146 class 2		@ U _{LN} = 230 V _{AC} ; f _{sw} = default; IEC 146 class 1			@ U _{LN} = 230 V _{AC} ; f _{sw} = default; IEC 146 class 2		@ U _{LN} = 400 V _{AC} ; f _{sw} = default; IEC 146 class 1				@ U _{LN} = 400 V _{AC} ; f _{sw} = default; IEC 146 class 2		@ U _{LN} = 460 V _{AC} ; f _{sw} = default; IEC 146 class 1		@ U _{LN} = 460 V _{AC} ; f _{sw} = default; IEC 146 class 2		Voltage Factor K _V at 460 V _{AC} *	Temp. Factor K _T for ambient temperature	Switching frequency K _F
	kVA	kVA	kW	kW	Hp	Hp	kW	kW	Hp	Hp		V	Hz	A	A			A	A	kHz	kHz	K _V	K _T			
4220	32	29	11	11	15	15	22	22	30	25	0.98 x U _{LN} (AC Input voltage)	500	47	43	40	36	8		0.87							
4300	42	38.2	18.5	15	25	20	30	30	40	30		500	63	58	54	50	8	16	0.87							
4370	55	50	22	18.5	30	25	37	37	50	40		500	79	72	68	62	8	16	0.87							
5450	64	58.3	22	22	30	30	45	45	60	50		200	93	85	81	74	4	8	0.87							
5550	79	72	30	30	40	40	55	55	75	60		200	114	104	99	90	4	8	0.87	0.8 @ 50°C (122°F)						
6750	98	89.2	37	37	50	50	75	55	100	75		200	142	129	124	112	4	8	0.87			0.7 for higher f _{sw}				



*: Data recorded for operating conditions at an ambient temperature of 40 °C.



*: Dati riportati per condizioni di funzionamento a temperatura ambiente 40°C.



*: Données fournies pour des conditions de fonctionnement sous une température ambiante de 40°C.



*: Die angeführten Daten gelten unter Betriebsbedingungen bei einer Umgebungstemperatur von 40° C.







*: Datos para condiciones de trabajo en una temperatura ambiente de 40°C.

AVy...-EH, Input data

Dati in Uscita
Caractéristiques de Sortie

Ausgangsdaten
Datos de Salida

Drive Type	U _{LN} AC Input voltage	AC Input frequency	I _N AC Input current for continuous service, IEC 146 class 1 :						Max short circuit power without line reactor (Z _{min} = 1%)	Overvoltage threshold	Undervoltage threshold	Braking IGBT Unit, Standard internal (with external resistor) MAX braking torque
			- Connection with 3-phase reactor @ 230 V _{AC}	- Connection with 3-phase reactor @ 400 V _{AC}	- Connection with 3-phase reactor @ 460 V _{AC}	- Connection without 3-phase reactor @ 230 V _{AC}	- Connection without 3-phase reactor @ 400 V _{AC}	- Connection without 3-phase reactor @ 460 V _{AC}				
AVy...-EH	V	Hz	A	A	A	A	A	A	kVA	V	V	%
4220	230 V _{AC} -15% ... 480 V _{AC} +10%, 3Ph	50/60 Hz ± 5%	39	44	37	(1)	(1)	(1)	3200	410 V _{DC} (for 230 V _{AC} mains), 800 V _{DC} (for 400 V _{AC} mains), 820 V _{DC} (for 460 V _{AC} mains)	230 V _{DC} (for 230 V _{AC} mains), 380 V _{DC} (for 400 V _{AC} mains), 415 V _{DC} (for 460 V _{AC} mains)	150 (2)
4300			55	62	53	(1)	(1)	(1)	4200			150 (2)
4370			69	77	66	(1)	(1)	(1)	5500			150 (2)
5450			84	94	82	(1)	(1)	(1)	6400			150 (2)
5550			98	110	96	(1)	(1)	(1)	7900			150 (2)
6750			122	137	120	(1)	(1)	(1)	9800			(3)

-  (1): For these types an external inductance is recommended. (2): Optional internal braking unit (with external resistor). (3): External braking unit (optional).
-  (1): Per questi modelli è consigliato l'uso dell'induttanza di rete. (2): Unità di frenatura interna opzionale (con resistenza esterna). (3): Unità di frenatura esterna (opzionale).
-  (1): Pour ces modèles, il est conseillé d'utiliser une inductance de réseau. (2): Unité de freinage interne en option (avec résistance externe). (3): Unité de freinage extérieure (option).
-  (1): Für diese Modelle wird die Verwendung einer Netzdrossel empfohlen. (2): Optionale interne Bremsenheit (mit externem Widerstand). (3): Externe Bremsenheit (optional).
-  (1): Se recomienda una inductancia de red para este tipo. (2): Unidad de frenado interna opcional (con resistencia externa). (3): Unidad de frenado externo (opcional).

Inverter Selection

AVy...-WH, Output data

Dati in Uscita
Caratteristiche di Sortie

Ausgangsdaten
Datos de Salida

Drive Type	P _m mot (recommended motor output):										U ₂ Max output voltage	f ₂ Max output frequency	I _{2N} Rated output current :				f _{sw} switching frequency (Default)	f _{sw} switching frequency (Higher)	Derating factor:								
	Inverter Output (IEC 146 class 1), Continuous service (@ 400 V _{AC})		Inverter Output (IEC 146 class 2), 150% overload for 60s (@ 400 V _{AC})		@ U _{LN} = 230 V _{AC} ; f _{sw} = default; IEC 146 class 1		@ U _{LN} = 230 V _{AC} ; f _{sw} = default; IEC 146 class 2		@ U _{LN} = 230 V _{AC} ; f _{sw} = default; IEC 146 class 1				@ U _{LN} = 230 V _{AC} ; f _{sw} = default; IEC 146 class 2		@ U _{LN} = 400 V _{AC} ; f _{sw} = default; IEC 146 class 1				@ U _{LN} = 400 V _{AC} ; f _{sw} = default; IEC 146 class 2		@ U _{LN} = 460 V _{AC} ; f _{sw} = default; IEC 146 class 1		@ U _{LN} = 460 V _{AC} ; f _{sw} = default; IEC 146 class 2		Voltage Factor K _V at 460 V _{AC} *	Temp. Factor K _T for ambient temperature	Switching frequency K _F
	kVA	kVA	kW	kW	Hp	Hp	kW	kW	Hp	Hp			V	Hz	A	A			A	A	kHz	kHz	K _V	K _T			
3110	16.8	15.3	5.5	5.5	7.5	7.5	11	11	15	15		500	24.8	22.5	21.6	19.6	8	16	0.93								
3150	22.4	20.3	7.5	7.5	10	10	15	15	20	20		500	33	30	28.7	26	8	16	0.90								
4220	32	29	11	11	15	15	22	22	30	25		500	47	43	40	36	8	16	0.87								
4300	42	38.2	18.5	15	25	20	30	30	40	30		500	63	58	54	50	8	16	0.87								
4370	55	50	22	18.5	30	25	37	37	50	40		500	79	72	68	62	8	16	0.87								
5450	64	58.3	22	22	30	30	45	45	60	50	0.94 x U _{LN} (AC Input voltage)	200	93	85	81	74	4	8	0.87	0.8 @ 50°C (122°F)	0.7 for higher f _{sw}						
5550	79	72	30	30	40	40	55	55	75	60		200	114	104	99	90	4	8	0.87								
6750	98	89.2	37	37	50	50	75	55	100	75		200	142	129	124	112	4	8	0.87								
7900	128	116.5	55	45	75	60	90	90	125	100		200	185	169	160	146	4	8	0.87								
71100	145	132	55	55	75	75	110	90	150	125		200	210	191	183	166	4	8	0.87								
71320	173	157.5	75	55	100	75	132	110	150	150		200	250	227	217	198	4	8	0.87								



*: Data recorded for operating conditions with an ambient temperature of 40°C and a water-cooled heat sink (liquid temperature +20°C ... +30°C).



*: Dati riportati per condizioni di funzionamento a temperatura ambiente 40°C e dissipatore raffreddato ad acqua (temperatura liquido +20°C ... +30°C).



*: Données fournies pour des conditions de fonctionnement à une température ambiante de 40°C et dissipateur refroidi à l'eau (température du liquide +20°C ... +30°C).



*: Die angeführten Daten beziehen sich auf Betriebsbedingungen mit 40° C Umgebungstemperatur und wassergekühltem Kühlkörper (Flüssigkeitstemperatur +20° C ... +30° C).



*: Datos obtenidos para condiciones de funcionamiento a temperatura ambiente 40°C y disipador refrigerado por agua (temperatura del líquido de +20°C ... +30°C).

AVy...-WH, Input data

Dati in Ingresso
Caractéristiques d'Entrée

Eingangsdaten
Datos de Entrada

Drive Type	U _{LN} AC Input voltage	AC Input frequency	I _N AC Input current for continuous service, IEC 146 class 1 :						Max short circuit power without line reactor (Zmin= 1%)	Overvoltage threshold	Undervoltage threshold	Braking IGBT Unit, Standard internal (with external resistor) IMAX braking torque
			- Connection with 3-phase reactor @ 230 V _{AC}	- Connection with 3-phase reactor @ 400 V _{AC}	- Connection with 3-phase reactor @ 460 V _{AC}	- Connection without 3-phase reactor @ 230 V _{AC}	- Connection without 3-phase reactor @ 400 V _{AC}	- Connection without 3-phase reactor @ 460 V _{AC}				
AVy...-WH	V	Hz	A	A	A	A	A	A	kVA	V	V	%
3110			18.2	20.4	17.8	27.9	30.3	26.4	1700			90
3150			25 *	28.2 *	24.5 *	35.4 *	40 *	34.8 *	2250			90
4220	230 V _{AC} - 15% ... 480 V _{AC} + 10%, 3Ph	50/60 Hz ±5%	39	44	37	(1)	(1)	(1)	3200			150 (2)
4300			55	62	53	(1)	(1)	(1)	4200			150 (2)
4370			69	77	66	(1)	(1)	(1)	5500			150 (2)
5450			84	94	82	(1)	(1)	(1)	6400			150 (2)
5550			98	110	96	(1)	(1)	(1)	7900			150 (3)
6750			122	137	120	(1)	(1)	(1)	9800			(2),(3)
7900			158	177	153	(1)	(1)	(1)	12800			(2),(3)
71100			192	216	188	(1)	(1)	(1)	14500			(2),(3)
71320			220	247	214	(1)	(1)	(1)	17300			(2),(3)



*: Use of an external inductance is recommended for the stated dimensions.

(1): For these types an external inductance is recommended. (2): Optional internal braking unit (with external resistor). (3): Water-cooled internal braking resistor (optional).



*: Per le taglie indicate si consiglia comunque l'uso di un induttanza di rete.

(1): Per questi modelli è consigliato l'uso dell'induttanza di rete. (2): Unità di frenatura interna opzionale (con resistenza esterna). (3): Resistenza di frenatura interna raffreddata ad acqua (opzionale).



*: Pour les tailles indiquées, il est conseillé d'utiliser une inductance de réseau.

(1): Pour ces modèles, il est conseillé d'utiliser une inductance de réseau. (2): Unité de freinage interne en option (avec résistance externe). (3) : Résistance de freinage interne refroidie à l'eau (en option).



*: Für die angeführten Größen wird in jedem Fall die Verwendung einer Netzdrossel empfohlen.

(1): Für diese Modelle wird die Verwendung einer Netzdrossel empfohlen. (2): Optionale interne Bremsseinheit (mit externem Widerstand). (3): Interner Bremswiderstand mit Wasserkühlung (Option).



*: Se recomienda el uso de inductancias de red para las dimensiones establecidas.

(1): Se recomienda una inductancia de red para este tipo. (2): Unidad de frenado interna opcional (con resistencia externa). (3): Resistencia de frenado interna refrigerada por agua (opcional).





Typical Connection Scheme

AVy ...-EH, AVy ...-WH

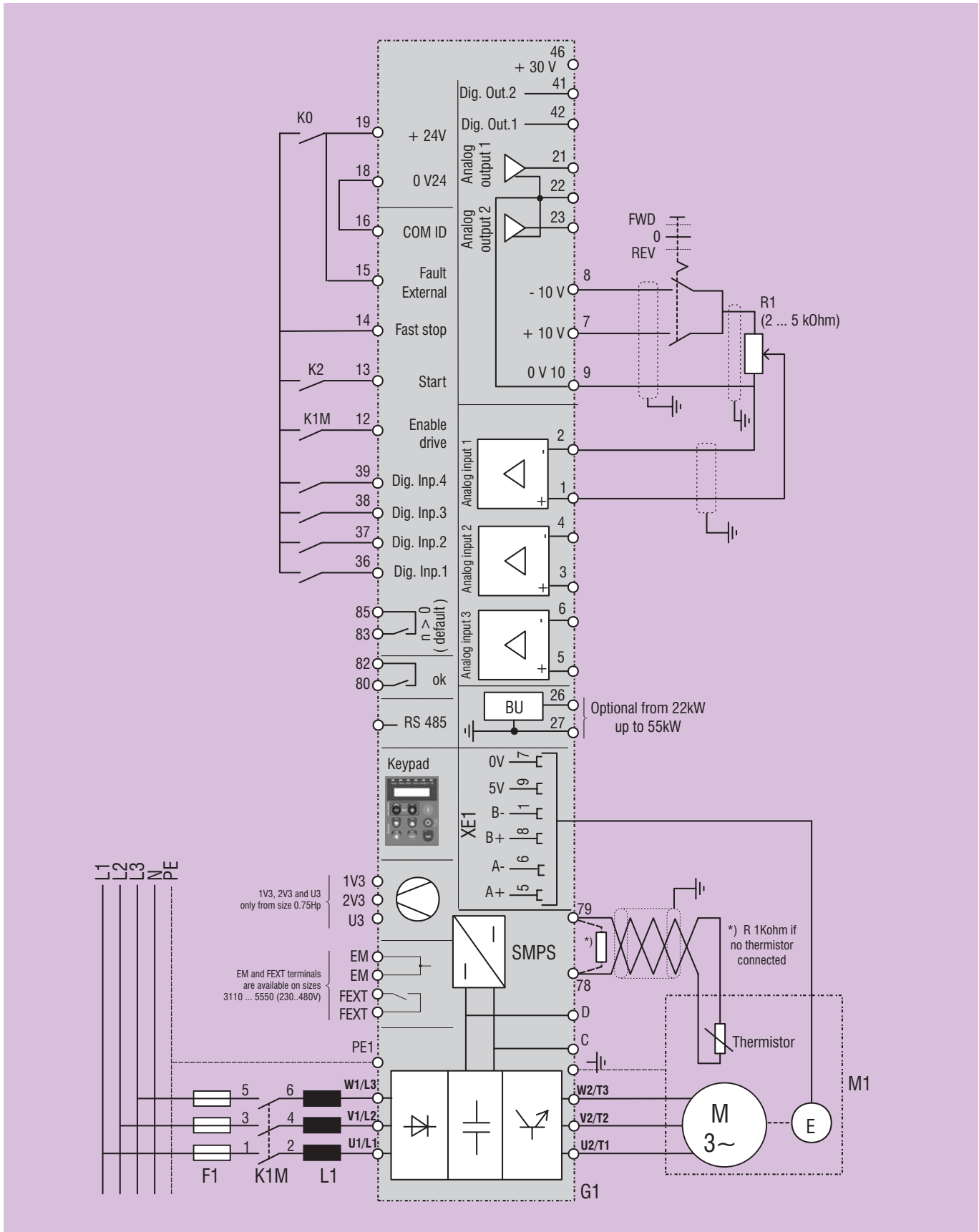
Schema Tipico di Collegamento
Schéma Typique de Raccordement

Typischer Anschlussplan
Diagrama Típico de Conexión



-  The connection diagram describes a typical inverter connection arrangement, set up to handle PNP logic "Terminal box commands". Refer to the instruction manual for additional detailed data.
-  Lo schema di collegamento indica una connessione tipica dell'inverter, predisposto per "Comandi da morsetteria" in logica PNP. Ulteriori informazioni dettagliate, sono disponibili nel relativo manuale d'istruzione.
-  Le schéma de connexion indique une connexion typique du variateur, prévu pour "Commandes par bornes" en logique PNP. Pour de plus amples informations voir la notice d'instruction correspondante.
-  Der Anschlussplan zeigt einen typischen Frequenzumrichteranschluss, der für "Befehle über Klemmleiste" in PNP-Logik bestimmt ist. Nähere Informationen sind dem entsprechenden Handbuch zu entnehmen.
-  El esquema de conexión describe un convertidor de frecuencia con una conexión típica, instalada para manejar en lógica PNP "Mandos de la Caja de Terminales". Utilice el manual de instrucciones para información detallada adicional.

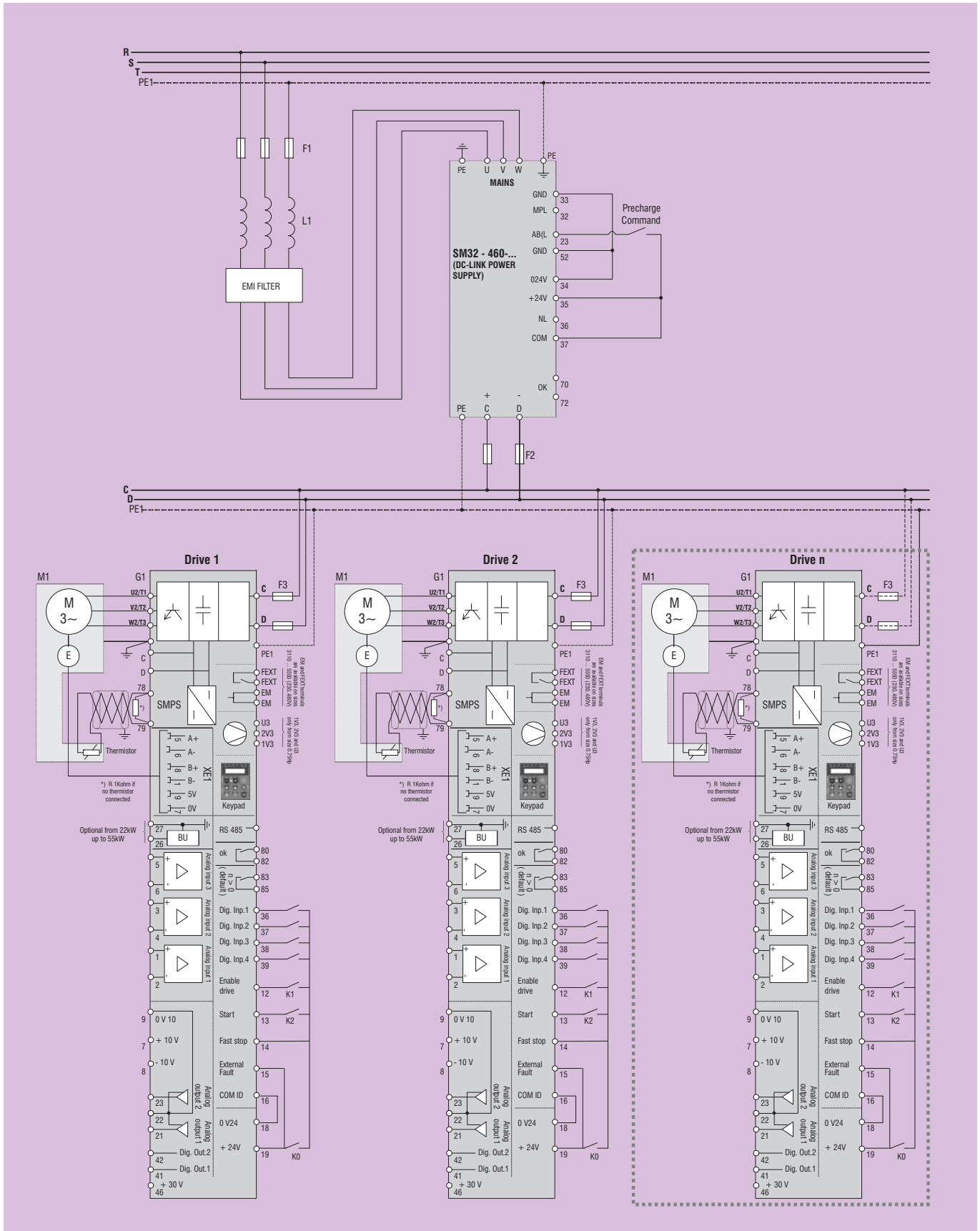

The connection diagram describes a typical inverter connection arrangement, set up to handle PNP logic "Terminal box commands". Refer to the instruction manual for additional detailed data.

Lo schema di collegamento indica una connessione tipica dell'inverter, predisposto per "Comandi da morsettiere" in logica PNP. Ulteriori informazioni dettagliate, sono disponibili nel relativo manuale d'istruzione.

Le schéma de connexion indique une connexion typique du variateur, prévu pour "Commandes par bornes" en logique PNP. Pour de plus amples informations voir la notice d'instruction correspondante.

Der Anschlussplan zeigt einen typischen Frequenzumrichteranschluss, der für "Befehle über Klemmleiste" in PNP-Logik bestimmt ist. Nähere Informationen sind dem entsprechenden Handbuch zu entnehmen.

El esquema de conexión describe un convertidor de frecuencia con una conexión típica, instalada para manejar en lógica PNP "Mandos de la Caja de Terminales". Utilice el manual de instrucciones para información detallada adicional.

Technical Specifications

Specifiche Tecniche
Spécifications Techniques

Technische Spezifikationen
Especificaciones Técnicas

Dimensions and Weights

AVy...-DC

Dimensioni e Pes
Dimensions et Poids
Abmessungen und Gewichte
Dimensiones y Pesos

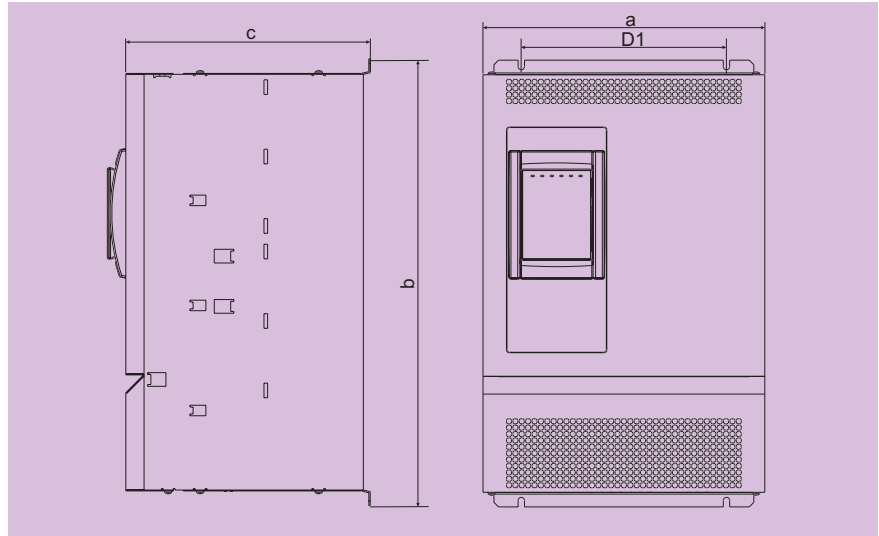

Mounting Method

Metodo di Montaggio
Mode de Montage
Montageart
Metodos de Montaje

- (D): Wall mounting
 Montaggio a muro
 Montage au mur
 Wandmontage
 Montaje a la pared

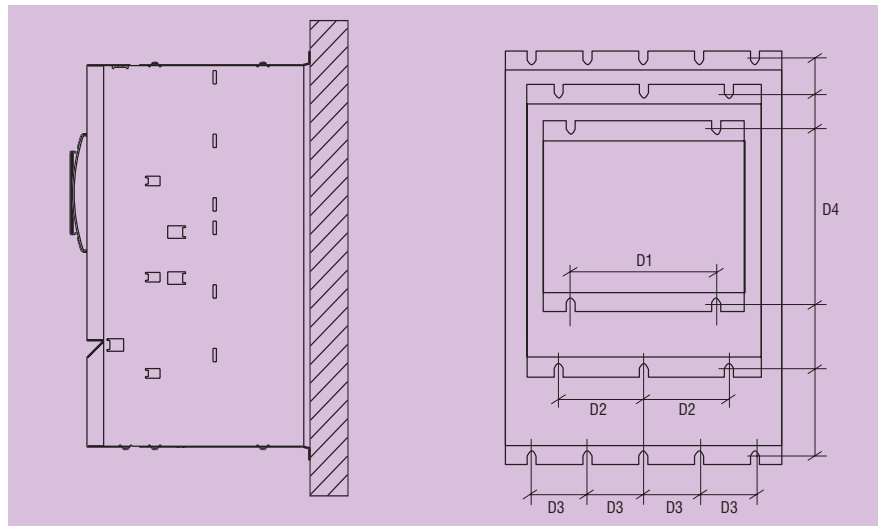

Dimensions mm [inch]	AVy...-DC										AVy.S...-DC			
	4220	4300	4370	5450	5550	6750	7900	7110	71320	81600	5S550	6S750	6S110	6S132
a	309 [12.1]	309 [12.1]	309 [12.1]	376 [14.7]	376 [14.7]	509 [20]	509 [20]	509 [20]	509 [20]	509 [20]	309 [12.1]	309 [12.1]	309 [12.1]	309 [12.1]
b	489 [19.2]	489 [19.2]	489 [19.2]	564 [22.2]	564 [22.2]	741 [29.2]	909 [35.8]	909 [35.8]	909 [35.8]	965 [38]	639 [25.2]	789 [31]	789 [31]	789 [31]
c	268 [10.5]	308 [12.1]	308 [12.1]	308 [12.1]	308 [12.1]	297.5 [11.7]	297.5 [11.7]	297.5 [11.7]	297.5 [11.7]	442 [17.4]	328 [12.9]	378 [14.9]	378 [14.9]	378 [14.9]
D1	225 [8.8]	225 [8.8]	225 [8.8]	-	-	-	-	-	-	-	225 [8.8]	225 [8.8]	225 [8.8]	225 [8.8]
D2	-	-	-	150 [15.9]	150 [15.9]	-	-	-	-	-	-	-	-	-
D3	-	-	-	-	-	100 [3.9]	100 [3.9]	100 [3.9]	100 [3.9]	100 [3.9]	-	-	-	-
D4	457 [18.7]	457 [18.7]	457 [18.7]	550 [21.6]	550 [21.6]	725 [28.5]	891 [35]	891 [35]	891 [35]	947 [37.3]	625 [24.6]	773 [30.4]	773 [30.4]	773 [30.4]
Ø d	M6	M6	M6	M6	M6	M6	M6	M6	M6	M6	M6	M6	M6	M6
Weight kg [lbs]	18 [39.6]	22 [48.5]	22.2 [48.9]	34 [74.9]	34 [74.9]	59 [130]	75.4 [166.1]	80.2 [176.7]	86.5 [190.6]	109 [240.3]	31.4 [69.2]	36.2 [79.8]	42.2 [93]	-- []

Special Versions

Dimensions and Weights

AVy...-C-DC-IP00,
AVy...-CP-DC-IP00

Dimensioni e Pes
Dimensions et Poids
Abmessungen und Gewichte
Dimensiones y Pesos

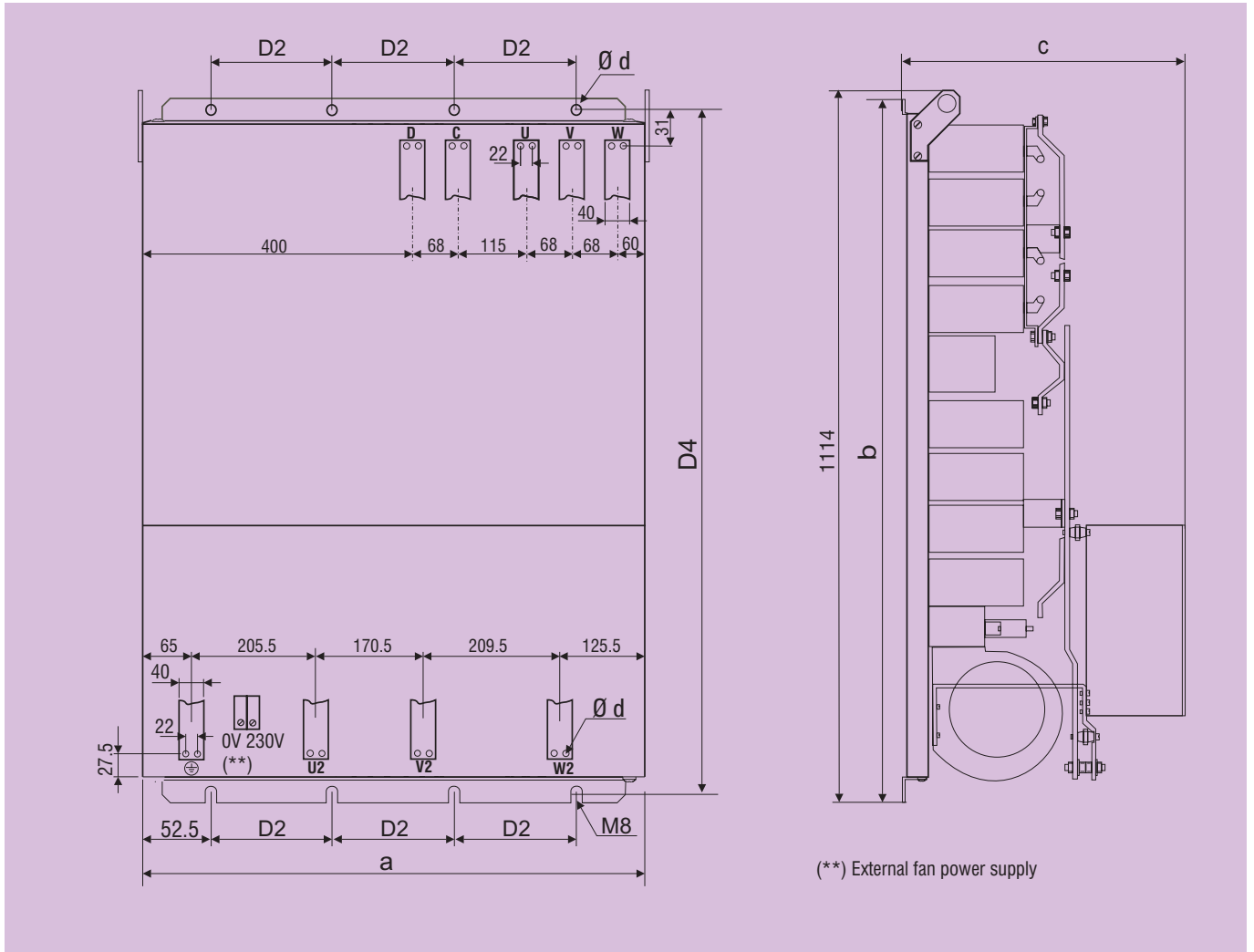

Note: input rectifier not included.

(D):Wall mounting.

Nota: ponte in ingresso non incluso.

(D):Montaggio a muro.

Remarque : pont à l'entrée non-compris.

(D):Montage au mur.

Hinweis: Brücke im Eingang nicht mitinbegriffen.

(D):Wandmontage.

Nota: puente de entrada no incluido.

(D):Montaje a la pared.

Type	Dimensions mm [inch]								Weight kg [lbs]
	a	b	c	D1	D2	D3	D4	Ø d	
AVy92500-C-DC-IP00	776 [30.6]	1091 [43]	430 [16.9]	-	225 [8.9]	-	1075 [42.3]	M8	...
AVy93150-CP-DC-IP00	776 [30.6]	1091 [43]	430 [16.9]	-	225 [8.9]	-	1075 [42.3]	M8	...

Dimensions and Weights

AVy...-DC-SLIM-IP00

Dimensioni e Pes
 Dimensions et Poids
 Abmessungen und Gewichte
 Dimensiones y Pesos

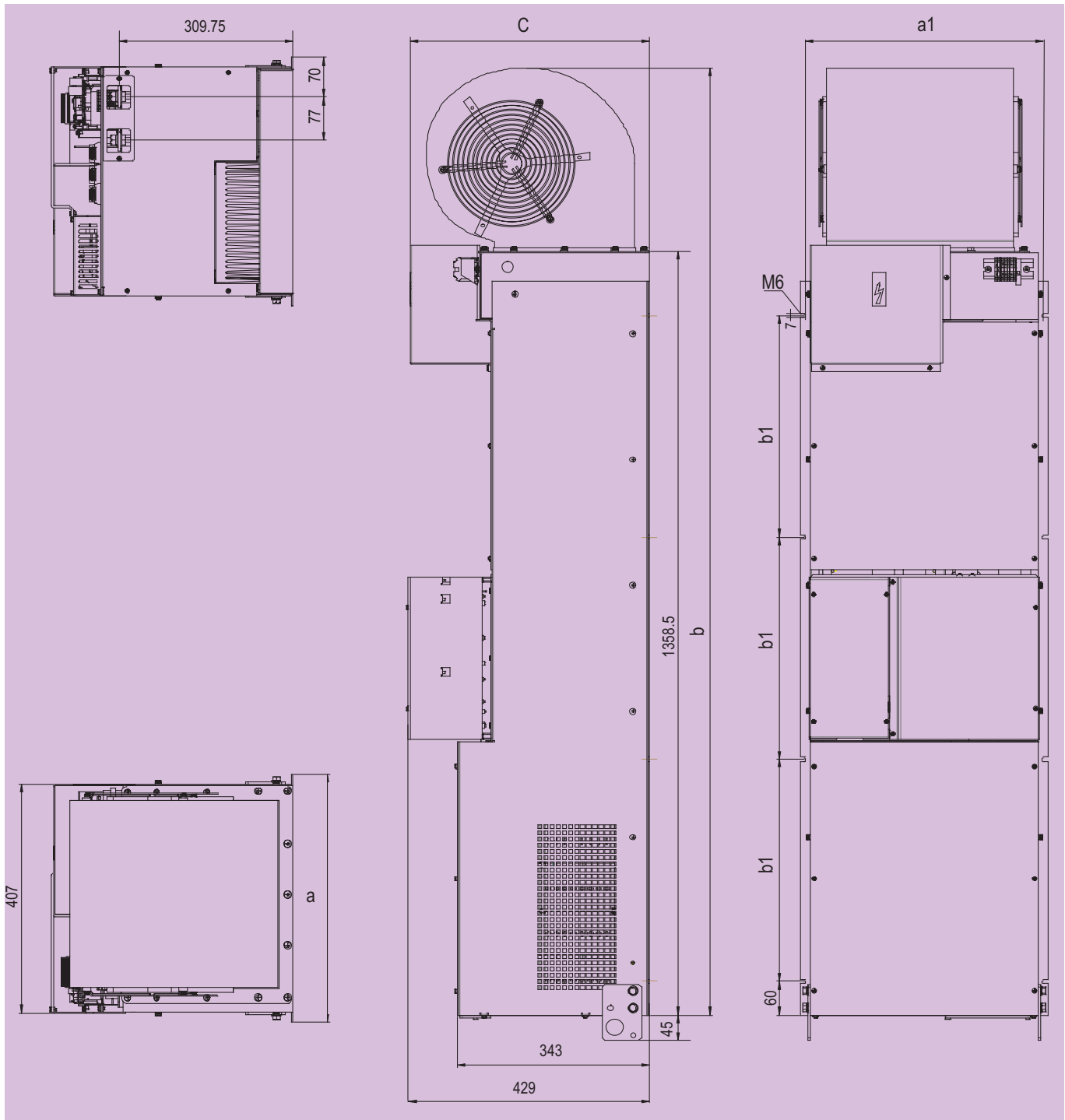

Type	Dimensions mm [inch]						Weight kg [lbs]
	a	b	c	a1	b1	Ø d	
AVy92500-...-DC-SLIM-...-IP00 + SI							
AVy93150-...-DC-SLIM-...-IP00 + SI	442 [17.40]	1685 [66.34]	426 [16.77]	424 [16.69]	395 [15.55]	M6	...
AVy93550-...-DC-SLIM-...-IP00 + SI							
AVy94000-...-DC-SLIM-...-IP00 + SI							

Special Versions

Dimensions and Weights

AVy...-EH

Dimensioni e Pes
 Dimensions et Poids
 Abmessungen und Gewichte
 Dimensiones y Pesos

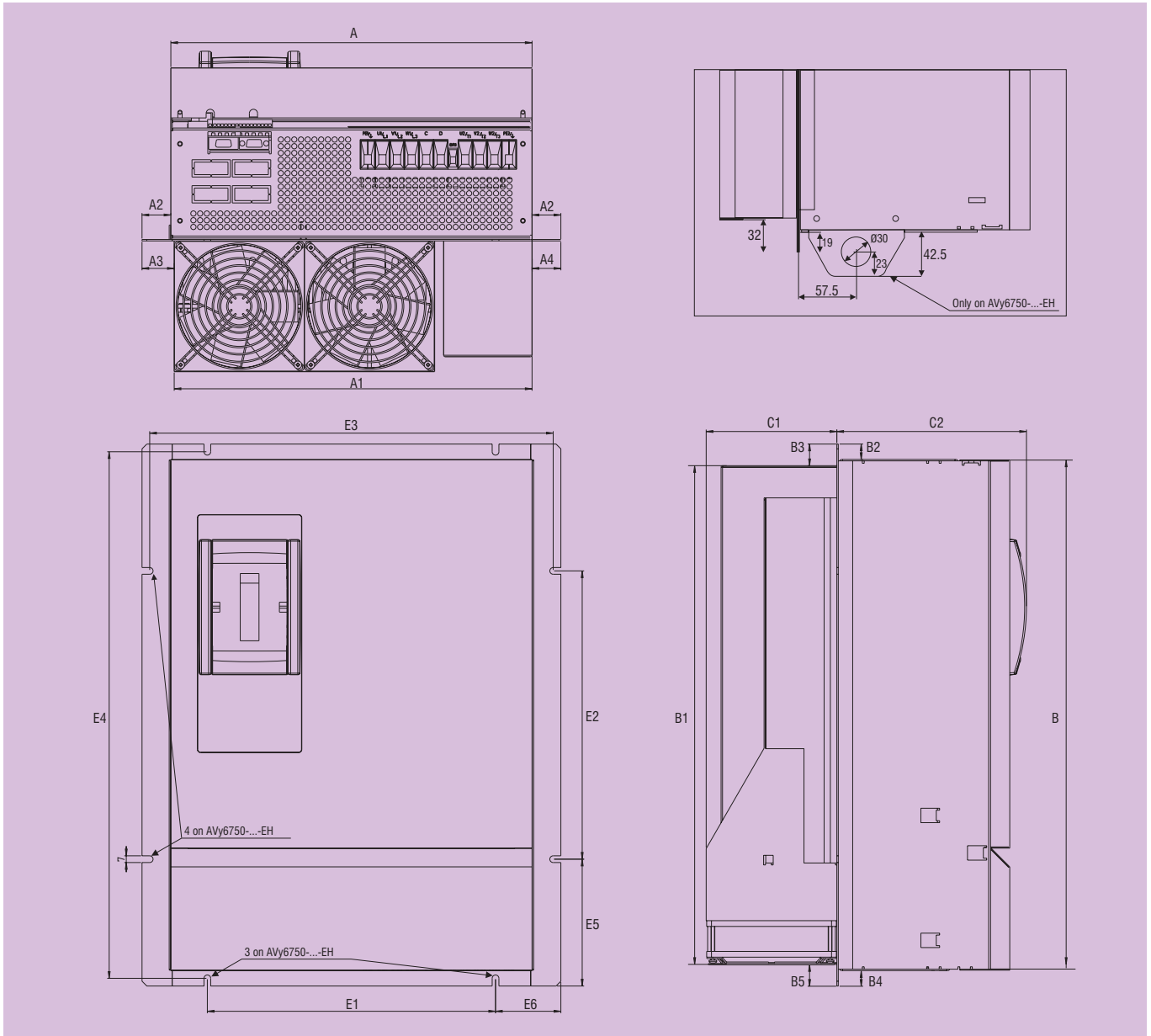

Type	Dimensions mm [inch]																			Weight kg [lbs]
	A	A1	A2	A3	A4	B	B1	B2	B3	B4	B5	C1	C2	E1	E2	E3	E4	E5	E6	
4220	309 [12.2]	303.5 [12]	30 [1.2]	35.5 [1.4]	30 [1.2]	457 [18]	414 [16.3]	24 [.94]	27 [1.06]	24 [.94]	64 [2.5]	100 [3.9]	207 [8.15]	200 [7.87]	250 [9.84]	350 [13.8]	490 [19.3]	127.5 [5.02]	84.5 [3.33]	-
4300	309 [12.2]	303.5 [12]	30 [1.2]	35.5 [1.4]	30 [1.2]	457 [18]	424 [16.7]	24 [.94]	27 [1.06]	24 [.94]	54 [2.1]	136 [5.34]	197 [7.76]	200 [7.87]	250 [9.84]	350 [13.8]	490 [19.3]	127.5 [5.02]	84.5 [3.33]	-
4370	309 [12.2]	303.5 [12]	30 [1.2]	35.5 [1.4]	30 [1.2]	457 [18]	439 [17.3]	24 [.94]	27 [1.06]	24 [.94]	39 [1.5]	152 [5.98]	197 [7.76]	200 [7.87]	250 [9.84]	350 [13.8]	490 [19.3]	127.5 [5.02]	84.5 [3.33]	-
5450	376 [12.2]	372.5 [14.7]	30 [1.2]	35.5 [1.4]	30 [1.2]	531 [20.9]	519 [20.4]	16 [.63]	22.5 [.89]	16 [.63]	22.5 [.89]	136 [5.35]	197 [7.76]	300 [11.8]	300 [11.8]	372.5 [14.7]	548 [21.6]	132 [5.2]	68 [2.68]	-
5550	376 [12.2]	372.5 [14.7]	30 [1.2]	35.5 [1.4]	30 [1.2]	531 [20.9]	519 [20.4]	16 [.63]	22.5 [.89]	16 [.63]	22.5 [.89]	136 [5.35]	197 [7.76]	300 [11.8]	300 [11.8]	372.5 [14.7]	548 [21.6]	132 [5.2]	68 [2.68]	-
6750	509 [20]	457 [18]	25.5 [1]	37.4 [1.5]	66 [2.6]	703 [27.7]	663 [26.1]	19 [.75]	32 [1.26]	20 [.79]	32 [1.26]	154 [6.06]	246 [6.7]	150 [5.9]	200 [7.87]	542 [21.34]	725 [28.5]	71.5 [2.81]	130 [5.12]	-

Technical Specifications

Dimensions and Weights

AVy...-WH

Dimensioni e Pes
 Dimensions et Poids
 Abmessungen und Gewichte
 Dimensiones y Pesos

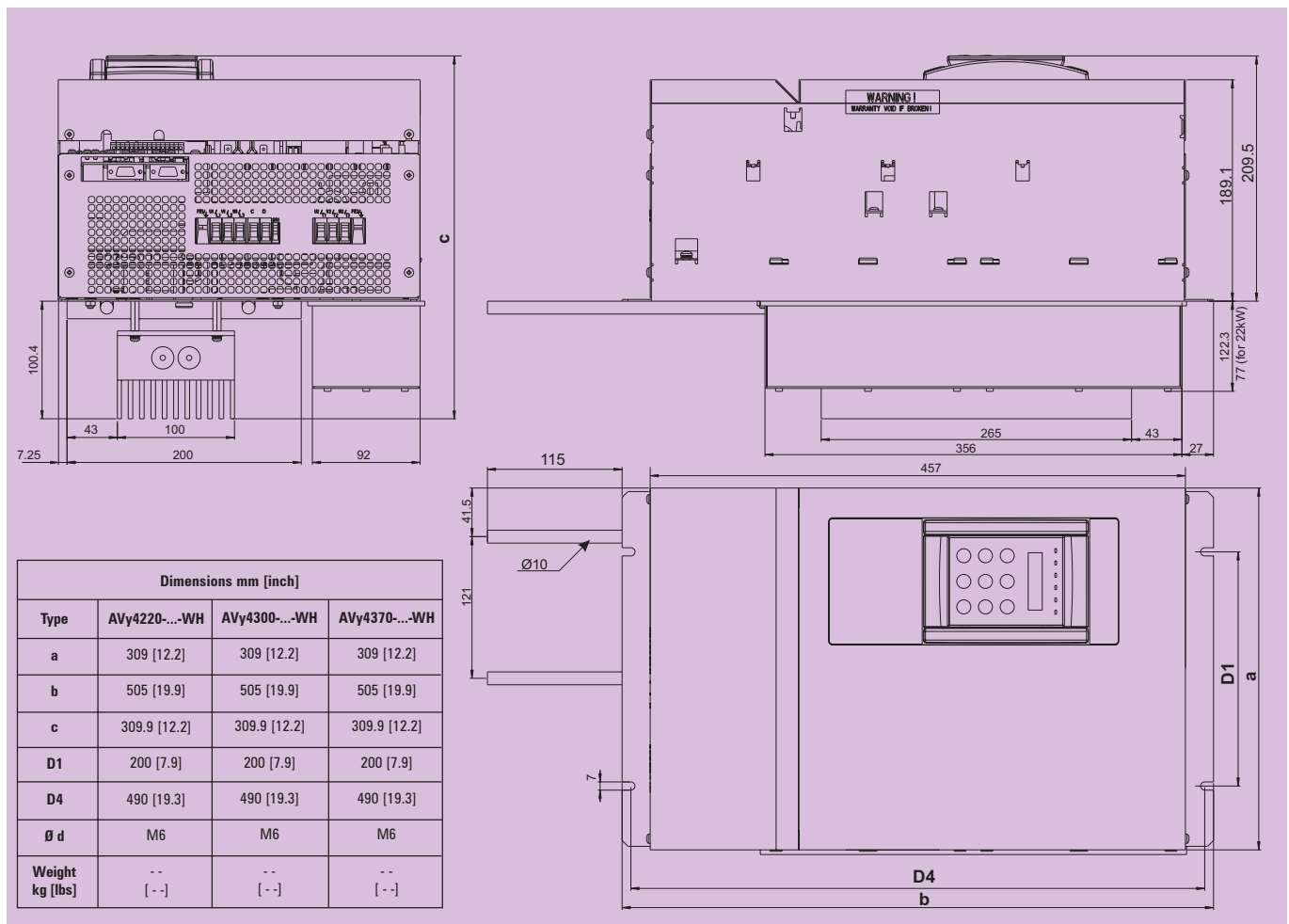
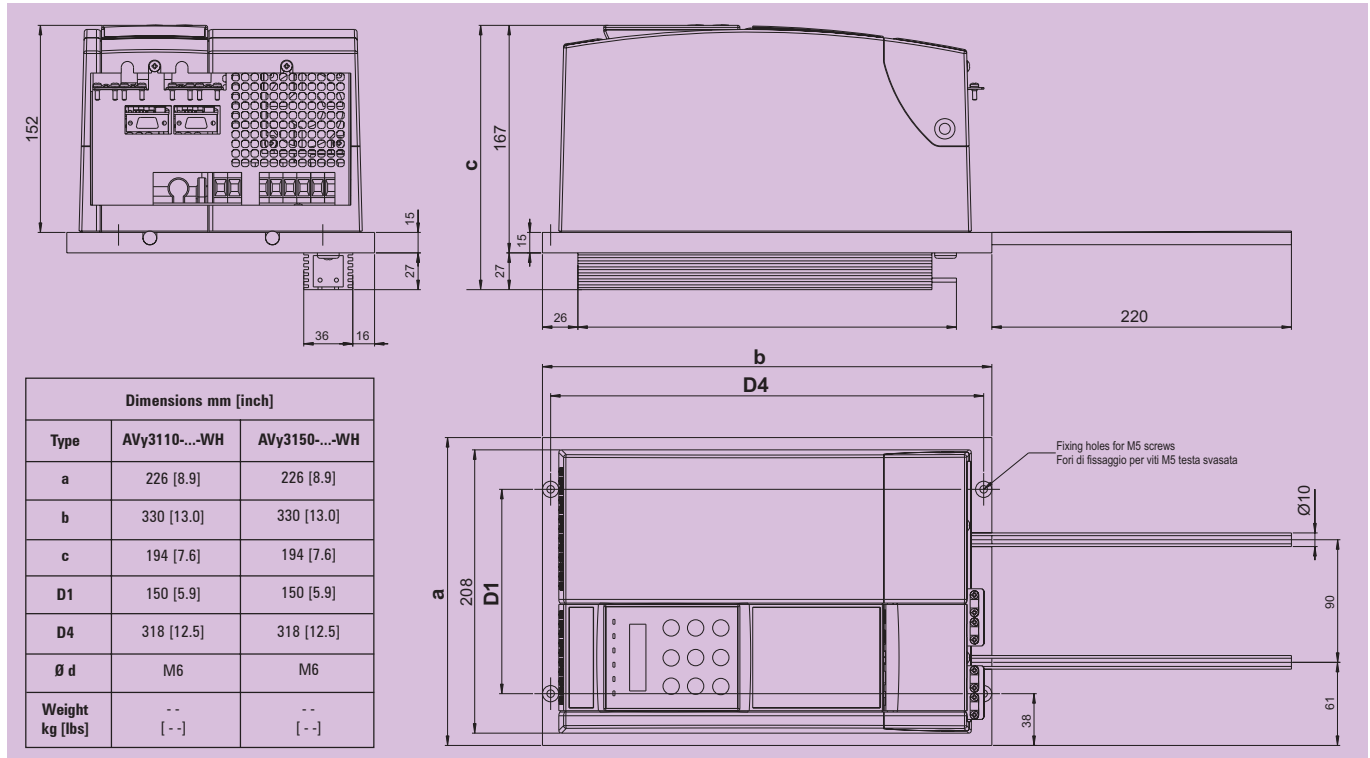

Special Versions

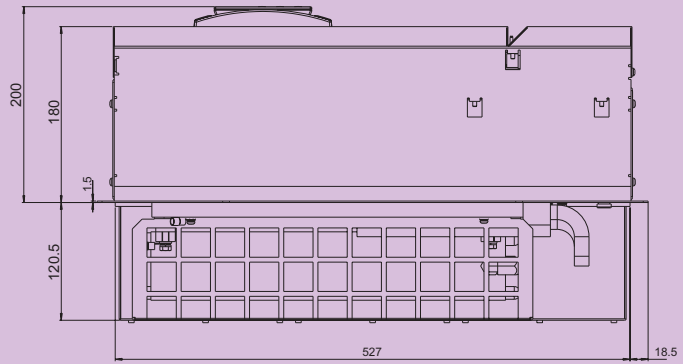
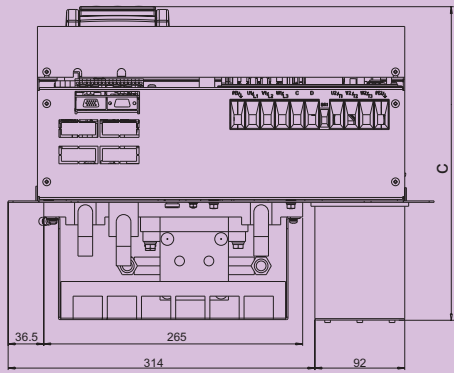

Dimensions mm [inch]		
Type	AVy5450-...-WH	AVy5550-...-WH
a	436 [17.2]	436 [17.2]
b	564 [22.2]	564 [22.2]
c	320.5 [12.6]	320.5 [12.6]
D1	300 [11.8]	300 [11.8]
D2	420 [16.5]	420 [16.5]
D3	424 [16.7]	424 [16.7]
D4	548 [21.6]	548 [21.6]
D5	124 [4.9]	124 [4.9]
Weight kg [lbs]	-- [-]	-- [-]

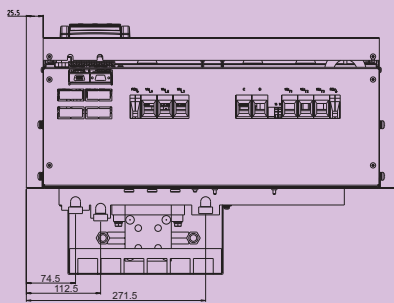
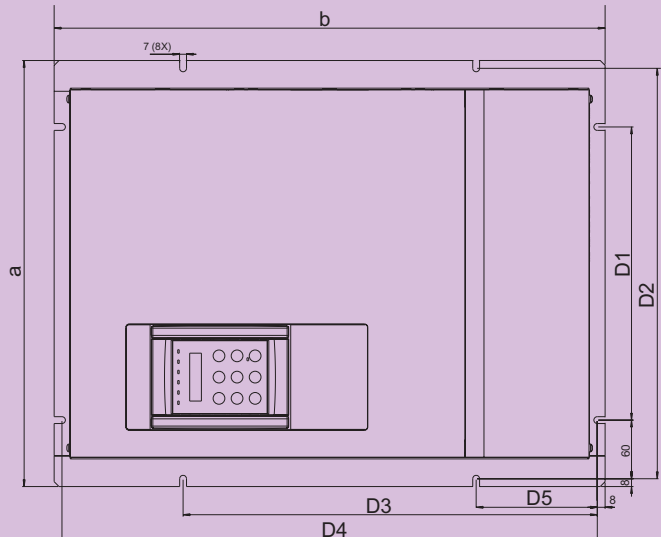

Dimensions mm [inch]	
Type	AVy6750-...-WH
a	560 [22]
b	743 [29.3]
c	358.5 [14.1]
D1	300 [11.8]
D2	542 [21.3]
D4	200 [7.9]
Weight kg [lbs]	-- [-]

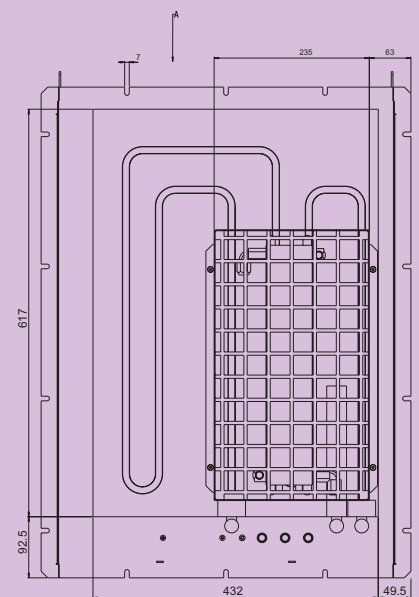
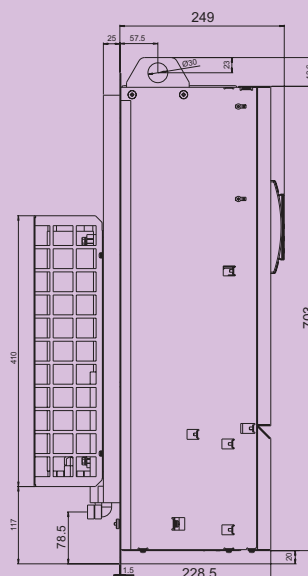
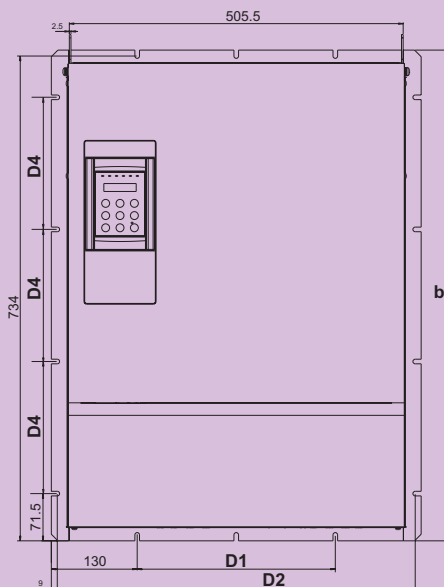
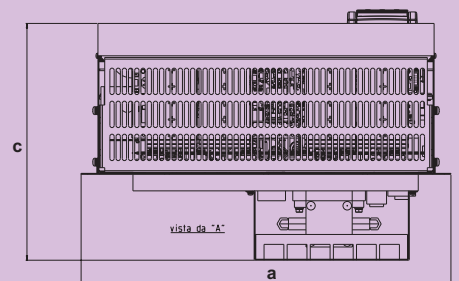

Technical Specifications

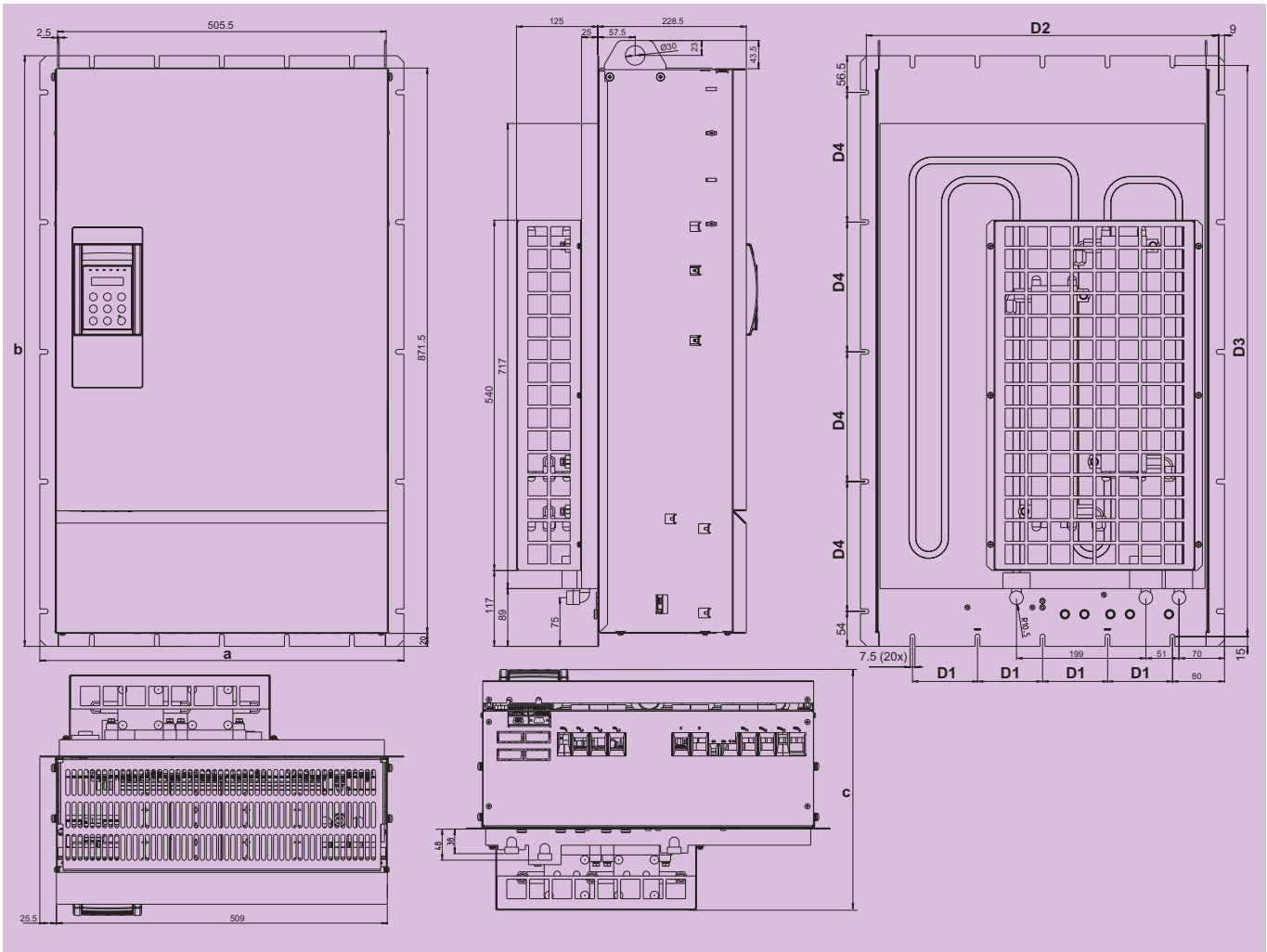

Type	Dimensions mm [inch]								Weight kg [lbs]
	a	b	c	D1	D2	D3	D4	-	
AVy7900-...-WH	560 [22]	910.5 [35.8]	353.5 [13.9]	100 [3.9]	542 [21.3]	880.5 [346.7]	200 [7.9]	-	...
AVy71100-...-WH	560 [22]	910.5 [35.8]	353.5 [13.9]	100 [3.9]	542 [21.3]	880.5 [346.7]	200 [7.9]	-	...
AVy71320-...-WH	560 [22]	910.5 [35.8]	353.5 [13.9]	100 [3.9]	542 [21.3]	880.5 [346.7]	200 [7.9]	-	...

Special Versions

Inverter Dissipation and Fan Flow *Dissipazione Inverter e Portata Ventilatori*
Dissipation du Variateur et Débit des Ventilateurs





Frequenzumrichter-Verlustleistung und Lüfterleistung
Disipación del Convertidor de Frecuencia y Ventilación forzada

Drive Type	P _V Heat dissipation (f _{sw} =default; I ₂ =I _{2N}):			Airflow of fan		Fluid flow	Minimum cooling opening	
	@U _{LN} =230 VAC	@U _{LN} =400 VAC	@U _{LN} =460 VAC	Internal fan	Heatsink fans (50Hz)		Control section	Heatsink
	W	W	W	m ³ / h	m ³ / h	l / min	cm ² (sq.inch)	cm ² (sq.inch)
AVy4220-DC	404	493	436	-	160	-	300 (47)	300 (47)
AVy4300-DC	531	648	585	-	170	-	400 (62)	400 (62)
AVy4370-DC	675	825	750	-	170	-	400 (62)	400 (62)
AVy5450-DC	768	937	825	-	340	-	740 (114.7)	740 (114.7)
AVy5550-DC	971	1185	1042	-	340	-	740 (114.7)	740 (114.7)
AVy6750-DC	1198	1462	1312	-	650	-	1240 (192.2)	1240 (192.2)
AVy7900-DC	1500	1830	1650	-	975	-	1240 (192.2)	1240 (192.2)
AVy71100-DC	1750	2137	1920	-	975	-	1240 (192.2)	1240 (192.2)
AVy71320-DC	2091	2550	2287	-	975	-	1240 (192.2)	1240 (192.2)
AVy81600-DC	2706	3300	2962	-	1820	-	3200 (496)	3200 (496)
AVy5S550-DC	971	1185	1042	-	340	-	103 (16)	740 (114.7)
AVy6S750-DC	1198	1462	1312	-	730	-	176 (27.3)	1240 (192.2)
AVy6S1100-DC	1319	1608	1320	-	730	-	176 (27.3)	1240 (192.2)
AVy6S1320-DC	1540	1878	1458	-	730	-	176 (27.3)	1240 (192.2)
AVy92500-C-DC	-	6400	5700	-	2 x 700	-	-	3200 (496)
AVy93150-CP-DC	-	8000	7900	-	2 x 700	-	-	3200 (496)
AVy92500-...-DC-SLIM	-	6300	5607	-	3000	-	-	3200 (496)
AVy93150-...-DC-SLIM	-	7990	7820	-	3000	-	-	3200 (496)
AVy93550-...-DC-SLIM-	-	8000	7000	-	3000	-	-	3200 (496)
AVy94000-...-DC-SLIM-	-	8000	7000	-	3000	-	-	3200 (496)
AVy4220-EH	404	493	436	-	160	-	84 (13)	-
AVy4300-EH	531	648	585	-	170	-	84 (13)	-
AVy4370-EH	675	825	750	-	170	-	84 (13)	-
AVy5450-EH	768	937	825	-	340	-	103 (16)	-
AVy5550-EH	971	1185	1042	-	340	-	103 (16)	-
AVy6750-EH	1198	1462	1312	-	650	-	176 (27.3)	-
AVy3110-WH	268	336	306	30	-	3	31 (4.8)	-
AVy3150-WH	378	461	421	30	-	3	31 (4.8)	-
AVy4220-WH	404	493	436	-	-	3	84 (13)	-
AVy4300-WH	531	648	585	-	-	3	84 (13)	-
AVy4370-WH	675	825	750	-	-	3	84 (13)	-
AVy5450-WH	768	937	825	-	-	4	103 (16)	-
AVy5500-WH	971	1185	1042	-	-	4	103 (16)	-
AVy6750-WH	1198	1462	1312	-	-	6	176 (27.3)	-
AVy71100-WH	1750	2137	1920	-	-	6	176 (27.3)	-
AVy71320-WH	2091	2550	2287	-	-	6	176 (27.3)	-

Codici di Ordinazione
Codes pour la Commande





Bestellnummern
Códigos de Mandos

Standard Versions: AVy... (Leds module KCS)

-  3 x 230VAC...480VAC power supplies (factory set for 400VAC-50Hz), Leds module KCS.
-  Alimentazione 3 x 230VAC...480VAC (impostazione di fabbrica per 400VAC-50Hz), Modulo a led KCS.
-  Alimentation 3 x 230VCA...480VCA (paramétrage en usine pour 400VAC-50Hz), Module à led KCS.
-  Versorgung 3 x 230VAC...480VAC (werkseitige Einstellung für 400VAC-50Hz), KCS LED-Modul.
-  Alimentación 3 x 230VAC...480VAC (ajuste de fábrica a 400VAC-50Hz), Modulo de leds KCS.

Code	Type	Rated power @ 400VAc	Standard settings
S9L01	AVy1007-XBX	0.75 kW	Braking unit
S9L02	AVy1015-XBX	1.5 kW	Braking unit
S9L03	AVy1022-XBX	2.2 kW	Braking unit
S9L04	AVy1030-XBX	3 kW	Braking unit
S9L05	AVy2040-XBX	4 kW	Braking unit
S9L06	AVy2055-XBX	5.5 kW	Braking unit
S9L07	AVy2075-XBX	7.5 kW	Braking unit
S9L08	AVy3110-XBX	11 kW	Braking unit
S9L09	AVy3150-XBX	15 kW	Braking unit
S9N32	AVy4185-XBX	18.5 kW	Braking unit
S9L11	AVy4220-XBX	22 kW	Braking unit
S9L31	AVy4300-XBX	30 kW	Braking unit
S9L33	AVy4370-XBX	37 kW	Braking unit
S9L15	AVy5450-XBX	45 kW	Braking unit
S9L18	AVy5550-XBX	55 kW	Braking unit
S9N31	AVy4185-XXX	18.5 kW	
S9L10	AVy4220-XXX	22 kW	
S9L11	AVy4300-XXX	30 kW	
S9L12	AVy4370-XXX	37 kW	
S9L13	AVy5450-XXX	45 kW	
S9L14	AVy5550-XXX	55 kW	
S9L36	AVy6750-XXX	75 kW	
S9L37	AVy7900-XXX	90 kW	
S9L39	AVy71100-XXX	110 kW	
S9L42	AVy71320-XXX	132 kW	
S9LL4	AVy81600-XXX	160 kW	
S9N35	AVy82000-XXX	200 kW	

Standard Versions: AVy... (Programming keypad KBS)

-  3 x 230VAC...480VAC power supplies (factory set for 400VAC-50Hz), Programming keypad KBS
-  Alimentazione 3 x 230VAC...480VAC (impostazione di fabbrica per 400VAC-50Hz), Tastierino di programmazione KBS.
-  Alimentation 3 x 230VCA...480VCA (paramétrage en usine pour 400VAC-50Hz), Clavier de programmation KBS.
-  Versorgung 3 x 230VAC...480VAC (werkseitige Einstellung für 400VAC-50Hz), Programmier-Bedieneinheit KBS.
-  Alimentación 3 x 230VAC...480VAC (ajuste de fábrica a 400VAC-50Hz), Teclado de programación KBS.







AVy1...-K..

Code	Type	Rated power @ 400VAc	Standard settings
S9L21	AVy1007-KBX	0.75 kW	Braking unit
S9L22	AVy1015-KBX	1.5 kW	Braking unit
S9L23	AVy1022-KBX	2.2 kW	Braking unit
S9L24	AVy1030-KBX	3 kW	Braking unit
S9L25	AVy2040-KBX	4 kW	Braking unit
S9L26	AVy2055-KBX	5.5 kW	Braking unit
S9L27	AVy2075-KBX	7.5 kW	Braking unit
S9L28	AVy3110-KBX	11 kW	Braking unit
S9L29	AVy3150-KBX	15 kW	Braking unit
S9N34	AVy4185-KBX	18.5 kW	Braking unit
S9LK1	AVy4220-KBX	22 kW	Braking unit
S9L41	AVy4300-KBX	30 kW	Braking unit
S9L35	AVy4370-KBX	37 kW	Braking unit
S9L17	AVy5450-KBX	45 kW	Braking unit
S9L20	AVy5550-KBX	55 kW	Braking unit
S9N33	AVy4185-KXX	18.5 kW	
S9L30	AVy4220-KXX	22 kW	

(to be continued)





Code	Type	Rated power @ 400VAc	Standard settings
S9L91	AVy4300-KXX	30 kW	
S9L34	AVy4370-KXX	37 kW	
S9L16	AVy5450-KXX	45 kW	
S9L19	AVy5550-KXX	55 kW	
S9L32	AVy6750-KXX	75 kW	
S9L38	AVy7900-KXX	90 kW	
S9L40	AVy71100-KXX	110 kW	
S9L43	AVy71320-KXX	132 kW	
S9LL5	AVy81600-KXX	160 kW	
S9N63	AVy82000-KXX	200 kW	

Standard Versions: AVy...-C and AVy...-CP (Programming keypad KBS)

-  3 x 400VAC...480VAC power supplies (factory set for 400VAC-50Hz), Programming keypad KBS
-  Alimentazione 3 x 400VAC...480VAC (impostazione di fabbrica per 400VAC-50Hz), Tastierino di programmazione KBS.
-  Alimentation 3 x 400VCA...480VCA (paramétrage en usine pour 400VAC-50Hz), Clavier de programmation KBS.
-  Versorgung 3 x 400VAC...480VAC (werkseitige Einstellung für 400VAC-50Hz), Programmier-Bedieneinheit KBS.
-  Alimentación 3 x 400VAC...480VAC (ajuste de fábrica a 400VAC-50Hz), Teclado de programación KBS.

Code	Type	Rated power @ 400VAc	Standard settings
S972N	AVy92500-KXX-C	250 kW	
S9N72	AVy93150-KXX-CP	315 kW	

Standard Versions: AVy...-4A (Programming keypad KBS)





-  3 x 230VAC...480VAC power supplies (factory set for 460VAC-50Hz), Programming keypad KBS
-  Alimentazione 3 x 230VAC...480VAC (impostazione di fabbrica per 460VAC-50Hz), Tastierino di programmazione KBS.
-  Alimentation 3 x 230VCA...480VCA (paramétrage en usine pour 460VAC-50Hz), Clavier de programmation KBS.
-  Versorgung 3 x 230VAC...480VAC (werkseitige Einstellung für 460VAC-50Hz), Programmier-Bedieneinheit KBS.
-  Alimentación 3 x 230VAC...480VAC (ajuste de fábrica a 460VAC-50Hz), Teclado de programación KBS.

Code	Type	Rated power @ 400VAc	Standard settings
S9R31	AVy1007-KBX-4A	0,75kW	Braking unit
S9R32	AVy1015-KBX-4A	1,5kW	Braking unit
S9R33	AVy1022-KBX-4A	2,2kW	Braking unit
S9R34	AVy1030-KBX-4A	3kW	Braking unit
S9R35	AVy2040-KBX-4A	4kW	Braking unit
S9R36	AVy2055-KBX-4A	5,5kW	Braking unit
S9R37	AVy2075-KBX-4A	7,5kW	Braking unit
S9R38	AVy3110-KBX-4A	11kW	Braking unit
S9R39	AVy3150-KBX-4A	15kW	Braking unit
S9R41	AVy4220-KBX-4A	22kW	Braking unit
S9R43	AVy4300-KBX-4A	30kW	Braking unit
S9R45	AVy4370-KBX-4A	37kW	Braking unit
S9R47	AVy5450-KBX-4A	45kW	Braking unit
S9R49	AVy5550-KBX-4A	55kW	Braking unit
S9R40	AVy4220-KXX-4A	22kW	
S9R42	AVy4300-KXX-4A	30kW	
S9R44	AVy4370-KXX-4A	37kW	
S9R46	AVy5450-KXX-4A	45kW	
S9R48	AVy5550-KXX-4A	55kW	
S9R50	AVy6750-KXX-4A	75kW	
S9R51	AVy7900-KXX-4A	90kW	
S9R52	AVy71100-KXX-4A	110kW	
S9R53	AVy71320-KXX-4A	132kW	
S9R54	AVy81600-KXX-4A	160kW	







AVy2...-K..

Standard Versions: AVy...-5 (Leds module KCS)

-  3 x 575VAC power supplies (factory set for 575VAC-60Hz), Leds module KCS
-  Alimentazione 3 x 575VAC (impostazione di fabbrica per 575VAC-60Hz), Modulo a led KCS
-  Alimentation 3 x 575VCA (paramétrage en usine pour 575VCA-60Hz), Module à led KCS.
-  Versorgung 3 x 575VAC (werkseitige Einstellung für 575VAC-60Hz), KCS LED-Modul.
-  Alimentación 3 x 575VAC (ajuste de fábrica a 575VAC-60Hz), Modulo de leds KCS.

Code	Type	Rated power @ 575VAc	Standard settings
S9LM1	AVy2002-XBX-5	2 HP	Braking unit
S9LM2	AVy2003-XBX-5	3 HP	Braking unit
S9LM3	AVy2005-XBX-5	5 HP	Braking unit
S9LM4	AVy3007-XBX-5	7.5 HP	Braking unit
S9LM5	AVy3010-XBX-5	10 HP	Braking unit
S9LM6	AVy3015-XBX-5	15 HP	Braking unit
S9LM7	AVy3020-XBX-5	20 HP	Braking unit
S9LM9	AVy4025-XBX-5	25 HP	Braking unit
S9LN2	AVy4030-XBX-5	30 HP	Braking unit
S9LN4	AVy4040-XBX-5	40 HP	Braking unit
S9LN6	AVy5050-XBX-5	50 HP	Braking unit
S9LN8	AVy5060-XBX-5	60 HP	Braking unit
S9L01	AVy6075-XBX-5	75 HP	Braking unit
S9LM8	AVy4025-XXX-5	25 HP	
S9LN1	AVy4030-XXX-5	30 HP	
S9LN3	AVy4040-XXX-5	40 HP	
S9LN5	AVy5050-XXX-5	50 HP	
S9LN7	AVy5060-XXX-5	60 HP	
S9LN9	AVy6075-XXX-5	75 HP	
S9L02	AVy6100-XXX-5	100 HP	
S9L03	AVy7125-XXX-5	125 HP	
S9L04	AVy7150-XXX-5	150 HP	
S9L05	AVy8200-XXX-5	200 HP	





Standard Versions: AVy...-5 (Programming keypad KBS)

-  3 x 575VAC power supplies (factory set for 575VAC-60Hz), Programming keypad KBS
-  Alimentazione 3 x 575VAC (impostazione di fabbrica per 575VAC-60Hz), Tastierino di programmazione KBS.
-  Alimentation 3 x 575VCA (paramétrage en usine pour 575VCA-60Hz), Clavier de programmation KBS.
-  Versorgung 3 x 575VAC (werkseitige Einstellung für 575VAC-60Hz), Programmier-Bedieneinheit KBS.
-  Alimentación 3 x 575VAC (ajuste de fábrica a 575VAC-60Hz), Teclado de programación KBS.

Code	Type	Rated power @ 575VAc	Standard settings
S9LP1	AVy2002-KBX-5	2 HP	Braking unit
S9LP2	AVy2003-KBX-5	3 HP	Braking unit
S9LP3	AVy2005-KBX-5	5 HP	Braking unit
S9LP4	AVy3007-KBX-5	7.5 HP	Braking unit
S9LP5	AVy3010-KBX-5	10 HP	Braking unit
S9LP6	AVy3015-KBX-5	15 HP	Braking unit
S9LP7	AVy3020-KBX-5	20 HP	Braking unit
S9LP9	AVy4025-KBX-5	25 HP	Braking unit
S9LQ2	AVy4030-KBX-5	30 HP	Braking unit
S9LQ4	AVy4040-KBX-5	40 HP	Braking unit
S9LQ6	AVy5050-KBX-5	50 HP	Braking unit
S9LQ8	AVy5060-KBX-5	60 HP	Braking unit
S9LR1	AVy5075-KBX-5	75 HP	Braking unit
S9LP8	AVy4025-KXX-5	25 HP	
S9LQ1	AVy4030-KXX-5	30 HP	
S9LQ3	AVy4040-KXX-5	40 HP	
S9LQ5	AVy5050-KXX-5	50 HP	
S9LQ7	AVy5060-KXX-5	60 HP	
S9LQ9	AVy5075-KXX-5	75 HP	
S9LR2	AVy7100-KXX-5	100 HP	
S9LR3	AVy7125-KXX-5	125 HP	
S9LR4	AVy7150-KXX-5	150 HP	
S9LR5	AVy8200-KXX-5	200 HP	



Cabinet Versions: AVy...-IP23 / IP54





-  3 x 400VAC...480VAC power supplies (factory set for 400VAC-50Hz), Programming keypad KBS
-  Alimentazione 3 x 400VAC...480VAC (impostazione di fabbrica per 400VAC-50Hz), Tastierino di programmazione KBS.
-  Alimentation 3 x 400VCA...480VCA (paramétrage en usine pour 400VAC-50Hz), Clavier de programmation KBS.
-  Versorgung 3 x 400VAC...480VAC (werkseitige Einstellung für 400VAC-50Hz), Programmier-Bedieneinheit KBS.
-  Alimentación 3 x 400VAC...480VAC (ajuste de fábrica a 400VAC-50Hz), Teclado de programación KBS.



AVy9..., AVy10...





Code	Type	Rated power @ 400Vac	Standard settings
S9L46	AVy92500-KXX-IP23	250 kW	
S9L47	AVy92500-KXX-IP54	250 kW	
S9L48	AVy93150-KXX-IP23	315 kW	
S9L49	AVy93150-KXX-IP54	315 kW	
S9N26	AVy104000-KXX-IP23	400 kW	
	AVy104000-KXX-IP54	400 kW	
S9N28	AVy105000-KXX-IP23	500 kW	
	AVy105000-KXX-IP54	500 kW	
S9N30	AVy106300-KXX-IP23	630 kW	
	AVy106300-KXX-IP54	630 kW	

Open Frame Versions: AVy...-IP00

-  3 x 400VAC...480VAC power supplies (factory set for 400VAC-50Hz), Programming keypad KBS
-  Alimentazione 3 x 400VAC...480VAC (impostazione di fabbrica per 400VAC-50Hz), Tastierino di programmazione KBS.
-  Alimentation 3 x 400VCA...480VCA (paramétrage en usine pour 400VAC-50Hz), Clavier de programmation KBS.
-  Versorgung 3 x 400VAC...480VAC (werkseitige Einstellung für 400VAC-50Hz), Programmier-Bedieneinheit KBS.
-  Alimentación 3 x 400VAC...480VAC (ajuste de fábrica a 400VAC-50Hz), Teclado de programación KBS.





Code	Type	Rated power @ 400Vac	Standard settings
S9N25	AVy104000-KXX-IP00	400 kW	
S9N27	AVy105000-KXX-IP00	500 kW	
S9N29	AVy106300-KXX-IP00	630 kW	

Open Frame Versions, Compact series: AVy...-C-IP00 and AVy...-CP-IP00

-  3 x 400VAC...480VAC power supplies (factory set for 400VAC-50Hz), Programming keypad KBS
-  Alimentazione 3 x 400VAC...480VAC (impostazione di fabbrica per 400VAC-50Hz), Tastierino di programmazione KBS.
-  Alimentation 3 x 400VCA...480VCA (paramétrage en usine pour 400VAC-50Hz), Clavier de programmation KBS.
-  Versorgung 3 x 400VAC...480VAC (werkseitige Einstellung für 400VAC-50Hz), Programmier-Bedieneinheit KBS.
-  Alimentación 3 x 400VAC...480VAC (ajuste de fábrica a 400VAC-50Hz), Teclado de programación KBS.

Code	Type	Rated power @ 400Vac	Standard settings
S970N	AVy92500-KXX-C-IP00	250 kW	
S9N70	AVy93150-KXX-CP-IP00	315 kW	

Special Versions: AVy...-DC (Leds module KCS)





-  Power supply via the DC bus, Leds module KCS.
-  Alimentazione via DC bus, Modulo a led KCS.
-  Version avec alimentation par CC bus, Module à led KCS.
-  Ausführung mit Speisung durch DC Bus, KCS LED-Modul.
-  Versión con alimentación mediante bus CC, Modulo de leds KCS.



AVy4...-K.-DC





Code	Type	Rated power	Standard settings
S901L	AVy4220-XXX-DC	22 kW	Power supply via the DC bus
S902L	AVy4300-XXX -DC	30 kW	Power supply via the DC bus
S903L	AVy4370-XXX-DC	37 kW	Power supply via the DC bus
S904L	AVy5450-XXX-DC	45 kW	Power supply via the DC bus
S905L	AVy5550-XXX-DC	55 kW	Power supply via the DC bus
S906L	AVy6750-XXX -DC	75 kW	Power supply via the DC bus
S907L	AVy7900-XXX -DC	90 kW	Power supply via the DC bus
S910L	AVy71100-XXX -DC	110 kW	Power supply via the DC bus
S911L	AVy71320-XXX -DC	132 kW	Power supply via the DC bus
S912L	AVy81600-XXX -DC	160 kW	Power supply via the DC bus
S913L	AVy82000-XXX -DC	200 kW	Power supply via the DC bus

Special Versions: AVy...-DC (Programming keypad KBS)

-  Power supply via the DC bus, Programming keypad KBS
-  Alimentazione via DC bus, Tastierino di programmazione KBS.
-  Version avec alimentation par CC bus, Clavier de programmation KBS.
-  Ausführung mit Speisung durch DC Bus, Programmier-Bedieneinheit KBS.
-  Versión con alimentación mediante bus CC, Teclado de programación KBS.





Code	Type	Rated power	Standard settings
S921L	AVy4220-KXX-DC	22 kW	Power supply via the DC bus
S922L	AVy4300-KXX -DC	30 kW	Power supply via the DC bus
S923L	AVy4370-KXX-DC	37 kW	Power supply via the DC bus
S924L	AVy5450-KXX-DC	45 kW	Power supply via the DC bus
S925L	AVy5550-KXX-DC	55 kW	Power supply via the DC bus
S926L	AVy6750-KXX -DC	75 kW	Power supply via the DC bus
S927L	AVy7900-KXX -DC	90 kW	Power supply via the DC bus
S928L	AVy71100-KXX -DC	110 kW	Power supply via the DC bus
S929L	AVy71320-KXX -DC	132 kW	Power supply via the DC bus
S930L	AVy81600-KXX -DC	160 kW	Power supply via the DC bus
S932L	AVy82000-KXX -DC	200 kW	Power supply via the DC bus

Special Versions, Slim series: AVy.S...-DC (Leds module KCS)

-  Power supply via the DC bus, Leds module KCS.
-  Alimentazione via DC bus, Modulo a led KCS.
-  Version avec alimentation par CC bus, Module à led KCS.
-  Ausführung mit Speisung durch DC Bus, KCS LED-Modul.
-  Versión con alimentación mediante bus CC, Modulo de leds KCS.





Code	Type	Rated power	Standard settings
S9R65	AVy5S550-XXX-DC	55 kW	Power supply via the DC bus
S9R66	AVy6S750-XXX-DC	75 kW	Power supply via the DC bus
S9R67	AVy6S1100-XXX-DC	110 kW	Power supply via the DC bus
S9R68	AVy6S1320-XXX-DC	132 kW	Power supply via the DC bus

Special Versions, Slim series: AVy.S...-DC (Programming keypad KBS)

-  Power supply via the DC bus, Programming keypad KBS
-  Alimentazione via DC bus, Tastierino di programmazione KBS.
-  Version avec alimentation par CC bus, Clavier de programmation KBS.
-  Ausführung mit Speisung durch DC Bus, Programmier-Bedieneinheit KBS.
-  Versión con alimentación mediante bus CC, Teclado de programación KBS.

Code	Type	Rated power	Standard settings
S9R69	AVy5S550-KXX-DC	55 kW	Power supply via the DC bus
S9R70	AVy6S750-KXX-DC	75 kW	Power supply via the DC bus
S9R71	AVy6S1100-KXX-DC	110 kW	Power supply via the DC bus
S9R72	AVy6S1320-KXX-DC	132 kW	Power supply via the DC bus





Special Versions, Slim series, Open Frame : AVy...-DC-SLIM+SI (Programming keypad KBS)

-  Power supply via the DC bus, Programming keypad KBS, IP00, Safety card for disabling IGBT module control.
-  Alimentazione via DC bus, Tastierino di programmazione KBS, IP00, Scheda di sicurezza per esclusione comando moduli IGBT .
-  Version avec alimentation par CC bus, Clavier de programmation KBS, IP00, Carte de sécurité pour l'exclusion de la commande des modules IGBT.
-  Ausführung mit Speisung durch DC Bus, Programmier-Bedieneinheit KBS, IP00, Sicherheitskarte für den Ausschluss der IGBT Modul-Befehle.
-  Versión con alimentación mediante bus CC, Teclado de programación KBS, IP00, Tarjeta de seguridad para exclusión del comando del módulo IGBT.







Code	Type	Rated power	Standard settings
S9R90	AVy92500-KXX-DC-SLIM-IP00+SI	250kW	Power supply via the DC bus, IP00 (Ovld 150%), Safety card included
S9R81	AVy93150-KXX-DC-SLIM-LD-IP00+SI	315kW	Power supply via the DC bus, IP00 (Ovld 110%), Safety card included
S9R92	AVy93150-KXX-DC-SLIM-IP00+SI	315kW	Power supply via the DC bus, IP00 (Ovld 150%), Safety card included
S9R93	AVy93550-KXX-DC-SLIM-LD-IP00+SI	355kW	Power supply via the DC bus, IP00 (Ovld 110%), Safety card included
S9R94	AVy93550-KXX-DC-SLIM-IP00+SI	355kW	Power supply via the DC bus, IP00 (Ovld 150%), Safety card included
S9R82	AVy94000-KXX-DC-SLIM-LD-IP00+SI	400kW	Power supply via the DC bus, IP00 (Ovld 110%), Safety card included

Special Versions, Open Frame Compact series, DC supply: AVy...-C-DC-IP00 and AVy...-CP-DC-IP00

-  Power supply via the DC bus, Programming keypad KBS
-  Alimentazione via DC bus, Tastierino di programmazione KBS.
-  Version avec alimentation par CC bus, Clavier de programmation KBS.
-  Ausführung mit Speisung durch DC Bus, Programmier-Bedieneinheit KBS.
-  Versión con alimentación mediante bus CC, Teclado de programación KBS.

Code	Type	Rated power	Standard settings
S971N	AVy92500-KXX-C-DC-IP00	250 kW	Power supply via the DC bus
S9N71	AVy93150-KXX-CP-DC-IP00	315 kW	Power supply via the DC bus





Special Versions, External Heatsink: AVy...-EH (Programming keypad KBS)

-  3 x 230VAC...480VAC power supplies (factory set for 400VAC-50Hz), Programming keypad KBS
-  Alimentazione 3 x 230VAC...480VAC (impostazione di fabbrica per 400VAC-50Hz), Tastierino di programmazione KBS.
-  Alimentation 3 x 230VCA...480VCA (paramétrage en usine pour 400VAC-50Hz), Clavier de programmation KBS.
-  Versorgung 3 x 230VAC...480VAC (werkseitige Einstellung für 400VAC-50Hz), Programmier-Bedieneinheit KBS.
-  Alimentación 3 x 230VAC...480VAC (ajuste de fábrica a 400VAC-50Hz), Teclado de programación KBS.



Code	Type	Rated power @ 400Vac	Standard settings
S9N82	AVy4220-KBX-EH	22 kW	Braking unit
S9N84	AVy4300-KBX-EH	30 kW	Braking unit
S9N86	AVy4370-KBX-EH	37 kW	Braking unit
S9N88	AVy5450-KBX-EH	45 kW	Braking unit
S9N90	AVy5550-KBX-EH	55 kW	Braking unit
S9N81	AVy4220-KXX-EH	22 kW	
S9N83	AVy4300-KXX-EH	30 kW	
S9N85	AVy4370-KXX-EH	37 kW	
S9N87	AVy5450-KXX-EH	45 kW	
S9N89	AVy5550-KXX-EH	55 kW	
S9N91	AVy6750-KXX-EH	75 kW	

Special Versions, Liquid cooling versions: AVy...-WH (Programming keypad KBS)

-  3 x 230VAC...480VAC power supplies (factory set for 400VAC-50Hz), Leds module KCS.
-  Alimentazione 3 x 230VAC...480VAC (impostazione di fabbrica per 400VAC-50Hz), Modulo a led KCS.
-  Alimentation 3 x 230VCA...480VCA (paramétrage en usine pour 400VAC-50Hz), Module à led KCS.
-  Versorgung 3 x 230VAC...480VAC (werkseitige Einstellung für 400VAC-50Hz), KCS LED-Modul.
-  Alimentación 3 x 230VAC...480VAC (ajuste de fábrica a 400VAC-50Hz), Modulo de leds KCS.



Code	Type	Rated power @ 400Vac	Standard settings
	AVy3110-KBX-WH	11 kW	Braking unit
	AVy3150-KBX-WH	15 kW	Braking unit
	AVy4220-KBX-WH	22 kW	Braking unit
	AVy4300-KBX-WH	30 kW	Braking unit
	AVy4370-KBX-WH	37 kW	Braking unit
	AVy5450-KBX-WH	45 kW	Braking unit
	AVy5550-KBX-WH	55 kW	Braking unit
	AVy6750-KXX-WH	75 kW	
	AVy7900-KXX-WH	90 kW	
	AVy71100-KXX-WH	110 kW	
	AVy71320-KXX-WH	132 kW	

Input Side External Fuses (F1)

Without three-phase choke

*Fusibili Esterni Lato Ingresso,
senza Induttore Trifase*

*Fusibles Réseau Externes
sans Inductance Triphasée*

*Externe Sicherungen Eingangsseite,
ohne dreiphasige Netzdrossel*

*Fusibles Externos del Lado de Alimentación
de Red, sin Inductancia Trifásica*

AVy... (230...480V)	EUROPE		America	
	Drive type	Fuse type	Fuse code	Fuse type
AVy1007	GRD2/10	F4D13	FWP10	S7G49
AVy1015	GRD2/10	F4D13	FWP10	S7G49
AVy1022	GRD2/16	F4D14	FWP20	S7G48
AVy1030	GRD2/16	F4D14	FWP20	S7G48
AVy2040	GRD2/20	F4D15	FWP20	S7G48
AVy2055	GRD2/25	F4D16	FWP25	S7G51
AVy2075	GRD3/35	F4D20	FWP35	S7G86
AVy3110	GRD3/50	F4D21	FWP40	S7G52
AVy3150	GRD3/50	F4D21	FWP40	S7G52
AVy4220 ... 106300	(*)		(*)	

 (*): For these types an external choke is mandatory if the AC input impedance is equal or less than 1%.

 (*): Per questi modelli l'induttanza esterna è obbligatoria se l'impedenza della rete è uguale o inferiore all'1%.

 (*): Pour ces tailles, une inductance externe est requise si l'impédance du réseau est inférieure ou égale à 1%.

 (*): Für diese Modelle ist die Netzdrossel notwendig, falls die Netzimpedanz gleich bzw. kleiner 1% ist.

 (*): Para estos modelos, la inductancia externa es obligatoria si la impedancia de la red es igual o inferior al 1%.

With three-phase choke

*Fusibili Esterni Lato Ingresso,
con Induttore Trifase*

*Fusibles Réseau Externes
avec Inductance Triphasée*

*Externe Sicherungen Eingangsseite,
mit dreiphasiger Netzdrossel*

*Fusibles Externos del Lado de Alimentación
de Red, con Inductancia Trifásica*

AVy... (230...480V)	EUROPE		America	
	Drive type	Fuse type	Fuse code	Fuse type
AVy1007	GRD2/10	F4D13	FWP10	S7G49
AVy1015	GRD2/10	F4D13	FWP10	S7G49
AVy1022	GRD2/10	F4D13	FWP10	S7G49
AVy1030	GRD2/16	F4D14	FWP20	S7G48
AVy2040	GRD2/16	F4D14	FWP20	S7G48
AVy2055	GRD2/20	F4D15	FWP20	S7G48
AVy2075	GRD2/25	F4D16	FWP25	S7G51
AVy3110	GRD3/50	F4D21	FWP35	S7G86
AVy3150	GRD3/50	F4D21	FWP40	S7G52
AVy4220	GRD3/50	F4D21	FWP50	S7G53
AVy4185	GRD3/50	F4D21	FWP50	S7G53
AVy4300	S00C+/üf1/80/100A/660V	F4EAG	FWP80	S7G54
AVy4370	S00C+/üf1/80/100A/660V	F4EAG	FWP100	S7G55
AVy5450	S00C+/üf1/80/160A/660V	F4EAL	FWP175	S7G57
AVy5550	S00C+/üf1/80/160A/660V	F4EAL	FWP175	S7G57
AVy6750	S1üf1/110/250A/660V	F4G28	FWP300	S7G60
AVy7900	S1üf1/110/250A/660V	F4G28	FWP300	S7G60
AVy71100	S2üf1/110/400A/660V	F4G34	FWP300	S7G60
AVy71320	S2üf1/110/400A/660V	F4G34	FWP300	S7G60
AVy81600	S2üf1/110/400A/660V	F4G34	FWP400	S7G62
AVy82000	S2üf1/110/500A/660V	F4G30	FWP500	S7G63
AVy92500	S2üf1/110/630A/660V	F4E31	A70P600	S7G65
AVy93150	S2üf1/110/630A/660V	F4E31	A70P600	S7G65
AVy104000	G3MU01 (1000A/660V)	F4G76	G3MU01 (1000A/660V)	F4G76
AVy105000	G3MU01 (1000A/660V)	F4G76	G3MU01 (1000A/660V)	F4G76
AVy106300	G3MU01 (1000A/660V)	F4G76	G3MU01 (1000A/660V)	F4G76

With or without three-phase choke on AC input

	AVy ... -5 (575V)	EUROPE		America	
	Drive type	Fuse type	Fuse code	Fuse type	Fuse code
<i>Fusibili Esterni Lato Ingresso, Collegamento con o senza Induttore Trifase</i>	AVy2002	GRD2/10	F4D13	FWP10A14F	S7G49
	AVy2003	GRD2/10	F4D13	FWP10A14F	S7G49
<i>Fusibles Réseaux Externes, utilisation avec ou sans Inductance Triphasée</i>	AVy2005	GRD2/16	F4D14	FWP15	S848B
	AVy3007	GRD2/25	F4D16	FWP25	S7G51
<i>Externe Sicherungen Eingangsseite, Anschluss mit oder ohne dreiphasige Netzdrössel</i>	AVy3010	Z14GR32	F4M11	FWP30A14F	S7I50
	AVy3015	GRD3/50	F4D21	FWP40	S7G52
<i>Fusibles Externos del Lado de Alimentación de Red, Inductancia Trifásica Opcional</i>	AVy3020	GRD3/50	F4D21	FWP50	S7G49
	AVy4025	GRD3/50	F4D21	FWP50	S7G49
	AVy4030	GRD3/50	F4D21	FWP50	S7G49
	AVy4040	Z22GR63	F4M17	FWP60B	S7I34
	AVy5050	S00C+/üf1/80/80A/660V	F4EAF	FWP80	S7G54
	AVy5060	S00C+/üf1/80/100A/660V	F4EAG	FWP100	S7G55
	AVy5075	S00C+/üf1/80/125A/660V	F4EAJ	FWP125	S849B
	AVy6100	S00C+/üf1/80/160A/660V	F4EAL	FWP150	S7G56
	AVy7125	S1üf1/110/250A/660V	F4G28	FWP200	S7G58
	AVy7150	S1üf1/110/250A/660V	F4G28	FWP250	S7G59
AVy8200	S2üf1/110/400A/660V	F4G34	FWP400	S7G62	

External Fuses for a DC Connection

*Fusibili Esterni per la Connessione DC
Fusibles Externes pour Raccordement sur Bus DC
Externe Sicherungen für DC-Anschluss
Fusibles Externos para Conexión en CC*

AVy... (230...480V)	EUROPE		America	
Drive type	Fuse type	Fuse code	Fuse type	Fuse code
AVy1007	Z14GR6	F4M01	FWP10A14F	S7G49
AVy1015	Z14GR10	F4M03	FWP10A14F	S7G49
AVy1022	Z14GR10	F4M03	FWP10A14F	S7G49
AVy1030	Z14GR16	F4M05	FWP20A14F	S7G48
AVy2040	Z14GR16	F4M05	FWP20A14F	S7G48
AVy2055	Z14GR20	F4M07	FWP20A14F	S7G48
AVy2075	Z14GR32	F4M11	FWP30A14F	S7I50
AVy3110	Z14GR40	F4M13	FWP40B	S7G52
AVy3150	Z22GR63	F4M17	FWP60B	S7I34
AVy4185	S00C+/üf1/80/80A/660V	F4EAF	FWP80	S7G54
AVy4220	S00C+/üf1/80/80A/660V	F4EAF	FWP80	S7G54
AVy4300	S00C+/üf1/80/100A/660V	F4EAG	FWP100	S7G55
AVy4370	S00C+/üf1/80/125A/660V	F4EAJ	FWP150	S7G56
AVy5450	S00C+/üf1/80/160A/660V	F4EAL	FWP175	S7G57
AVy5550	S00üF1/80/200A/660V	F4G23	FWP200	S7G58
AVy6750	S1üF1/110/250A/660V	F4G28	FWP250	S7G59
AVy7900	S1üF1/110/315A/660V	F4G30	FWP350	S7G61
AVy71100	S2üF1/110/400A/660V	F4G34	FWP400	S7G62
AVy71320	S2üF1/110/500A/660V	F4E30	FWP500	S7G63
AVy81600	S2üF1/110/500A/660V	F4E30	FWP500	S7G63
AVy82000	S2üf1/110/630A/660V	F4E31	FWP600	S7G65
AVy92500				
AVy93150				
AVy93550				
AVy94000	For information refer to Gefran-Siei commercial Offices			
AVy104000				
AVy105000				
AVy106300				
AVy5S550	S00üF1/80/200A/660V	F4G23	FWP200	S7G58
AVy6S750	S1üF1/110/250A/660V	F4G28	FWP250	S7G59
AVy6S1100	S1üF1/110/400A/660V	F4G34	FWP400	S7G62
AVy6S1320	S1üF1/110/500A/660V	F4E30	FWP500	S7G63

AVy ... -5 (575V)	EUROPE		America	
	Drive type	Fuse type	Fuse code	Fuse type
AVy2002			A100P15	S85A0
AVy2003			A100P15	S85A0
AVy2005			A100P20	S85A1
AVy3007			A100P30	S85A2
AVy3010			FWJ35	S85A3
AVy3015			FWJ50	S85A4
AVy3020			FWJ60	S85A5
AVy4025			FWJ60	S85A5
AVy4030			FWJ70	S85A6
AVy4040			FWJ80	S85A7
AVy5050			FWJ100	S85A8
AVy5060			FWJ125	S85A9
AVy5075			FWJ150	S85B0
AVy6100			FWJ200	S85B1
AVy7125			FWJ250	S85B2
AVy7150			FWJ250	S85B2
AVy8200			FWJ400	S85B4



The fuse technical data, such as dimensions, weights, dissipated power, heat etc. can be found in the relevant fuse manufacturer catalogues (GRD..., S..., Z...= Jean Muller; FWP...= Bussmann; A...=Gould Shawmut).



I dati tecnici dei fusibili, come ad esempio dimensioni, peso, dissipazione, calore, ecc. sono disponibili nei relativi cataloghi del costruttore fusibili (GRD..., S..., Z...= Jean Muller; FWP...= Bussmann; A...=Gould Shawmut).



Les caractéristiques techniques des fusibles telles que, les dimensions, le poids, la dissipation, etc., sont indiquées dans les catalogues correspondants du fabricant de fusibles (GRD..., S..., Z...= Jean Muller; FWP...= Bussmann; A...=Gould Shawmut).



Die technischen Daten der Sicherungen, wie beispielsweise Abmessungen, Gewicht, Verlustleistung, Wärme, usw. sind den entsprechenden Katalogen der Sicherungshersteller zu entnehmen (GRD..., S..., Z...= Jean Muller; FWP...= Bussmann; A...=Gould Shawmut).



Los datos técnicos de los fusibles, tales como dimensiones, peso, energía disipada, calor, etc. se pueden encontrar en los catálogos de fabricantes de fusibles (GRD..., S1..., Z...= Jean Muller; FWP...= Bussmann; A...=Gould Shawmut).

Input and Output Chokes - EMC Filters - External Braking Resistor

Induttori di ingresso e d'uscita, Filtri EMC,
Resistenze di frenatura esterne

Inducteur de réseau et Inducteur de sortie,
Filtres EMC , Résistances de freinage externe

Netz- und Ausgangsdrosseln, EMV-Filter, Externer
Bremswiderstand

Inductancias de entrada y de salida, Filtros EMC,
Resistencia del frenado externa



Recommended combinations, electrical ratings and dimensions of these accessories are listed in the Gefran-Siei Accessories catalogue (1S9109).

L'abbinamento consigliato, i dati elettrici e dimensionali di questi accessori sono riportati nel catalogo Accessori di Gefran-Siei (1SXXX).

La combinaison conseillée et les caractéristiques électriques et dimensionnelles de ces accessoires figurent dans le catalogue des accessoires de Gefran-Siei (1S9109).

Empfohlene Kombination, sowie elektrische und dimensionale Daten dieser Zubehöre werden im Katalog der Zubehöre von Gefran-Siei (1S9109) aufgeführt.

Los acoplamientos aconsejados, los datos eléctricos y las dimensiones de estos accesorios se encuentran en el catálogo de Accesorios de Gefran-Siei (1S9109).

External Braking Unit

Unità di Frenatura Esterna
Unité de Freinage Extérieure
Externe Bremsseinheiten
Unidad de Frenado Externa



AVy... (230...480V)		
Code	Type	Description
S9D50	BU32 460-20	Braking unit 20 A rms, power supply 230 ... 460 V
S9D51	BU32 460-50	Braking unit 50 A rms, power supply 230 ... 460 V
S9D52	BU32 460-85	Braking unit 85 A rms, power supply 230 ... 460 V
S9D55	BUy1020	Braking unit 20 A rms, power supply 230 ... 460 V / UL recognized
S9D56	BUy1050	Braking unit 50 A rms, power supply 230 ... 460 V / UL recognized
S9D57	BUy1085	Braking unit 85 A rms, power supply 230 ... 460 V / UL recognized

AVy ... -5 (575V)		
Code	Type	Description
S9D62	BUy 1075-5	Braking unit 75 A rms, power supply 575 V / UL recognized

This device has to be combined with one or more suitably dimensioned external resistor.

Questo accessorio deve essere abbinato con una o più resistenze esterne opportunamente dimensionate.

Cet accessoire doit être accouplé à une ou plusieurs résistances externes dimensionnées comme il se doit.

Dieses Zubehörteil muss mit einem oder mehreren externen Widerständen in entsprechender Größe kombiniert werden.

Este accesorio se debe acoplar con una o más resistencias exteriores de dimensiones oportunas.

Options

Opzioni
Options

Optionen
Opciones

Programming keypad







Code	Type	Description
S5R04	KBS	Programming keypad
S5R06	KCS	Leds module
S5WW2	Kit for the mounting of the remote AVy keypad	Kit for a remotable setting of KBS and KCS keypads

I/O Expansion EXP-D8R4





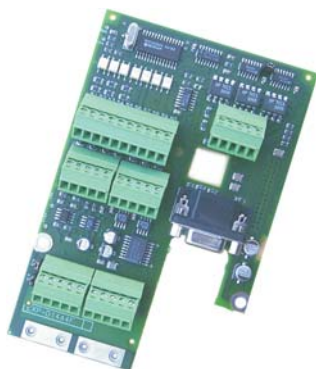

Code	Type	Description
S5R80	EXP-D8R4	Input / Output expansion

-  Inverter standard input / output expansion card:
 - 8 digital inputs (+15V_{DC}...+24V_{DC} ± 10%, max 9mA)
 - 4 relay complete with exchange contact (250V_{AC} - 5A max/ 24V_{DC} - 400mA).
-  Scheda di espansione degli ingressi/uscite standard dell'inverter.
 - 8 Ingressi digitali (+15V_{DC}...+24V_{DC} ± 10%, max 9mA)
 - 4 relè con contatto di scambio (230V_{AC} - max 5A / 24V_{DC} - 400mA).
-  Carte d'extension des entrées/sorties standard du variateur :
 - 8 Entrées digitales (+15V_{CC}...+24V_{CC} ± 10%, maxi 9mA)
 - 4 relais avec contact inverseur (230V_{CA} - maxi 5A / 24V_{CC} - 400mA).
-  Erweiterungskarte für die Standard-Eingänge/Ausgänge des Frequenzumrichters:
 - 8 Digitaleingänge (+15V_{DC}...+24V_{DC} ± 10%, max 9mA)
 - 4 Relais mit Wechselkontakt (230V_{AC} - max 5A / 24V_{DC} - 400mA).
-  Esquema de expansión del inverter estándar de entrada/salida de corriente:
 - 8 entradas digitales (+15V_{CC}...+24V_{CC} ± 10%, máx 9mA)
 - 4 relé de contacto conmutado (230V_{AC} - máx 5A / 24V_{CC} - 400mA).

Digital Input Expansion EXP-D14A4F



Code	Type	Description
S5R81	EXP-D14A4F	Input / Output expansion

-  Inverter standard input / output expansion card:
 - 8 digital inputs (+15V_{DC}...+30V_{DC}, max 9mA)
 - 6 digital outputs (+15V_{DC}...+30V_{DC}, max 50mA)
 - 2 differential analog inputs (voltage: ±10V, < 0.5mA; current: 0...20mA, 4...20mA)
 - 2 analog outputs (±10V, max 0.5mA)
 - 1 optocoupled digital encoder input interface (standard inputs: A+, A-, B+, B-, 0+, 0; Additional input for Encoder qualifier: C1+, C1-).
-  Scheda di espansione degli ingressi/uscite standard dell'inverter:
 - 8 ingressi digitali (+15V_{DC}...+30V_{DC}, max 9mA)
 - 6 uscite digitali (+15V_{DC}...+30V_{DC}, max 50mA)
 - 2 ingressi analogici differenziali (in tensione: ±10V, < 0,5mA; in corrente: 0...20mA, 4...20mA)
 - 2 uscite analogiche (±10V, max 0,5mA)
 - 1 interfaccia optoisolata per encoder digitale incrementale (ingressi standard: A+, A-, B+, B-, 0+, 0; Ingresso addizionale per camma di zero: C1+, C1-).
-  Carte d'extension des entrées/sorties standard du variateur :
 - 8 entrées digitales (+15V_{DC}...+30V_{DC}, maxi 9mA)
 - 6 sorties digitales (+15V_{DC}...+30V_{DC}, maxi 50mA)
 - 2 entrées analogiques différentielles (en tension : ±10V, < 0,5mA ; en courant : 0...20mA, 4...20mA)
 - 2 sorties analogiques (±10V, maxi 0,5mA)
 - 1 interface opto-isolée pour codeur numérique incrémental (entrées standard : A+, A-, B+, B-, 0+, 0; Entrée supplémentaire pour came de zéro : C1+, C1-).
-  Erweiterungskarte für die Standard-Eingänge/Ausgänge des Frequenzumrichters:
 - 8 Digitaleingänge (+15V_{DC}...+30V_{DC}, max 9 mA)
 - 6 Digitalausgänge (+15V_{DC}...+30V_{DC}, max. 50 mA)
 - 2 differentiale Analogeingänge (für Spannung: ±10V, < 0,5 mA; für Strom: 0...20 mA, 4...20 mA)
 - 2 Analogausgänge (±10V, max. 0,5 mA)
 - 1 optoisolierte Schnittstelle für inkrementalen Digitalencoder (Standardeingänge: A+, A-, B+, B-, 0+, 0; Zusätzlicher Eingang für Nullstellungs-Nocken: C1+, C1-).

-  Esquema de expansión del inverter estándar de entrada/salida de corriente:
 - 8 entradas digitales (+15Vdc ...+30Vdc, máx 9mA)
 - 6 salidas digitales (+15 Vcc ...+30 Vcc, máximo 50 mA)
 - 2 entradas analógicas diferenciales (en tensión ±10 V, < 0,5 mA; en corriente: 0...20 mA, 420 mA)
 - 2 salidas analógicas (±10 V, máximo 0,5 mA)
 - 1 interface optoaislado para encoder digital incremental (entradas estándar: A+, A-, B+, B-, 0+, 0; Entradas adicionales para leva de cero: C1+, C1-).

**Digital Input Expansion
EXP-D20A6**

Code	Type	Description
S505L	EXP-D20A6	Input / Output expansion (*)

(*)

Caution: the I/O expansions of this card are completely supported only by the AVy...-4 and AVy...-5 models.

Attenzione: le espansioni I/O di questa scheda sono supportate integralmente solo dai modelli AVy...-4A e AVy...-5.

Attention: les expansions E/S de cette carte sont entièrement supportées uniquement par les modèles AVy...-4A et AVy...-5.

Achtung: Die I/O-Erweiterungen dieser Karte werden nur von den Modellen AVy...-4A und AVy...-5 vollständig unterstützt.

Atención: la ampliación E/S de esta placa son soportadas integralmente sólo en los modelos AVy...-4A y AVy...-5.



-  Inverter standard input / output expansion card:
 - 12 digital inputs (+15Vdc ...+30Vdc, máx 9mA)
 - 8 digital outputs (+15Vdc ...+30Vdc, max 50mA)
 - 2 differential analog inputs (voltage: ±10V, < 0.5mA; current: 0...20mA, 4...20mA)
 - 4 analog outputs (2 voltage: ±10V, max 0.5mA; 2 current: 0...20mA, 4...20mA).

-  Scheda di espansione degli ingressi/uscite standard dell'inverter:
 - 12 ingressi digitali (+15Vdc ...+30Vdc, máx 9mA)
 - 8 uscite digitali (+15Vdc ...+30Vdc, máx 50mA)
 - 2 ingressi analogici differenziali (in tensione: ±10V, < 0,5mA; in corrente: 0...20mA, 4...20mA)
 - 4 uscite analogiche (2 in tensione: ±10V, máx 0,5mA; 2 in corrente: 0...20mA, 4...20mA).

-  Carte d'extension des entrées/sorties standard du variateur :
 - 12 Entrées digitales (+15Vdc ...+30Vdc, máx 9mA)
 - 8 sorties digitales (+15Vdc ...+30Vdc, máx 50mA)
 - 2 entrées analogiques différentielles (en tension : ±10V, < 0,5mA ; en courant : 0...20mA, 4...20mA)
 - 4 sorties analogiques (2 en tension : ±10V, máx 0,5mA ; 2 en courant : 0...20mA, 4...20mA).

-  Erweiterungskarte für die Standard-Eingänge/Ausgänge des Frequenzumrichters:
 - 12 Digitaleingänge (+15Vdc ...+30Vdc, máx 9mA)
 - 8 Digitalausgänge (+15 Vdc ...+30 Vdc, máx. 50 mA)
 - 2 differentiale Analogeingänge (für Spannung: ±10 V, < 0,5mA; für Strom: 0...20 mA, 4...20 mA)
 - 4 Analogausgänge (2 für Spannung: ±10 V, máx. 0,5 mA; 2 für Strom: 0...20 mA, 4...20 mA).

-  Esquema de expansión del inverter estándar de entrada/salida de corriente:
 - 12 entradas digitales (+15Vdc ...+30Vdc, máx 9mA)
 - 8 salidas digitales (+15 Vcc ...+30 Vcc, máximo 50 mA)
 - 2 entradas analógicas diferenciales (en tensión ±10 V, < 0,5 mA; en corriente: 0...20 mA, 420 mA)
 - 4 salidas analógicas (2 en tensión: ±10V, máximo 0,5 mA; 2 en corriente: 0...20 mA, 4...20 mA).

**Digital Encoder Input Expansion
EXP-F2E**

Code	Type	Description
S504L	EXP-F2E	Digital encoder input expansion and encoder repeater



-  Digital encoder input expansion and encoder repeater card:
 - 1 optocoupled digital encoder input and encoder input qualifier (A, A-, B, B-, C, C-; +5Vdc or +15...24Vdc selectable)
 - 1 optocoupled encoder data repeater TTL (@5V) or HTL (@15 to 24V).

-  Scheda di espansione ingresso encoder digitale e ripetizione encoder:
 - 1 ingresso encoder digitale optoisolato e ingresso camma di zero (A, A-, B, B-, C, C-; +5Vdc o +15...24Vdc selezionabile)
 - 1 uscita in frequenza optoisolata ripetizione encoder TTL (@5V) o HTL (@15 to 24V).

-  Carte d'extension entrée codeur digital et répétition codeur :
 - 1 entrée codeur digital opto-isolée et entrée came de zéro (A, A-, B, B-, C, C-; +5Vcc ou +15...24Vcc pouvant être sélectionné)
 - 1 sortie en fréquence opto-isolée répétition codeur TTL (@5V) ou HTL (@15÷24V).

-  Erweiterungskarte Digitalencodereingang und Encoderwiederholung:
 - 1 optoisolierter Digitalencodereingang und Eingang Nocken für Nullstellung (A, A-, B, B-, C, C-; +5 VDC oder +15...24 VDC wählbar)
 - 1 optoisolierter Frequenzausgang für Encoderwiederholung TTL (bei 5 V) oder HTL (von 15 bis 24 V).

-  Tarjeta de ampliación de entrada de encoder digital y repetición de encoder:
 - 1 entrada de encoder digital optoaislada y entrada leva de cero (A, A-, B, B-, C, C-; +5Vdc o +15...24Vdc seleccionable)
 - 1 salida de frecuencia optoaislada de repetición de encoder TTL (@5V) o HTL (@15 a 24V).

Digital Encoder Repeater Expansion EXP-E



Code	Type	Description
S507L	EXP-E	Digital encoder repeater

- Digital encoder repeater expansion card:
- 1 optocoupled encoder data repeater TTL (@5V) or HTL (@15 to 24V) output.
- Scheda di espansione ripetizione encoder digitale:
- 1 uscita in frequenza optoisolata ripetizione encoder TTL (@5V) o HTL (@15 to 24V).
- Carte d'expansion répétition codeur digital :
- 1 sortie en fréquence opto-isolée répétition codeur TTL (@5V) ou HTL (@15-24V).
- Erweiterungskarte Digitalencodewiederholung:
- 1 optoisolierter Frequenz Ausgang für Encoderwiederholung TTL (bei 5 V) oder HTL (von 15 bis 24 V).
- Tarjeta de ampliación repetición encoder digital:
- 1 salida de frecuencia optoisolada de repetición de encoder TTL (@5V) o HTL (@15 a 24V).

Digital Encoder Repeater Expansion EXP-FO



Code	Type	Description
S503L	EXP-FO	Digital encoder repeater (not optocoupled)

- Digital encoder repeater expansion card:
- 1 encoder data repeater TTL (@5V) output.
- Scheda di espansione ripetizione encoder digitale:
- 1 uscita in frequenza ripetizione encoder TTL (@5V).
- Carte d'expansion répétition codeur digital :
- 1 sortie en fréquence répétition codeur TTL (@5V).
- Erweiterungskarte Digitalencodewiederholung:
- 1 Frequenz Ausgang für Encoderwiederholung TTL (bei 5 V).
- Tarjeta de ampliación repetición encoder digital:
- 1 salida de frecuencia repetición encoder TTL (@5V).

Digital Encoder Input Expansion EXP-FI

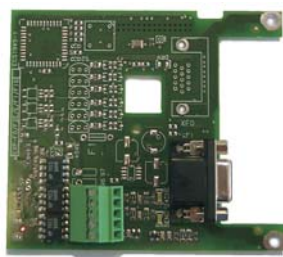

Code	Type	Description
S508L	EXP-FI	Digital encoder input



- Digital encoder input expansion card:
- 1 optocoupled digital encoder input (A, A-, B, B-, 0, 0-; +5Vdc or +15...24Vdc selectable) and encoder input qualifier (C, C-; 15Vdc ... 30Vdc).
- Scheda di espansione ingresso encoder digitale :
- 1 interfaccia optoisolata per encoder digitale (A, A-, B, B-, 0, 0-; +5Vdc o +15...24Vdc selezionabile) e camma di zero (C, C-; 15Vdc ... 30Vdc).
- 1 interface opto-isolée pour codeur digital (A, A-, B, B-, 0, 0-; +5Vcc ou +15...24Vcc pouvant être sélectionné) et came de zéro (C, C-; + 15Vcc ... + 30Vcc).
- Erweiterungskarte Digitalencodereingang:
- 1 optoisolierte Schnittstelle für Digitalencoder (A, A-, B, B-, 0, 0-; +5 Vdc oder +15...24 Vdc wählbar) und Nocken für Nullstellung (C, C-; 15 Vdc ... 30 Vdc).
- Tarjeta de ampliación entrada encoder digital:
- 1 interfaz optoisolada para encoder digital (A, A-, B, B-, 0, 0-; +5Vdc o +15...24Vdc seleccionable) y leva de cero (C, C-; 15Vdc ... 30Vdc).

Digital Encoder Input Expansion and Encoder Repeater EXP-FIO

Code	Type	Description
S509L	EXP-FIO	Digital encoder input expansion and encoder repeater

- Digital encoder input expansion card and encoder repeater:
- 1 optocoupled digital encoder input (A, A-, B, B-, 0, 0-; +5Vdc or +15...24Vdc selectable) and encoder input qualifier (C, C-; 15Vdc ... 30Vdc)
- 1 encoder data repeater TTL (@5V) output.
- Scheda di espansione ingresso encoder digitale e ripetizione encoder:
- 1 interfaccia optoisolata per ingresso encoder digitale (A, A-, B, B-, 0, 0-; +5Vdc o +15...24Vdc selezionabile) e camma di zero (C, C-; 15Vdc ... 30Vdc)
- 1 uscita in frequenza ripetizione encoder TTL (@5V).







-  Carte d'expansion entrée codeur digital et répétition codeur :
 - 1 interface opto-isolée pour entrée codeur digital (A, A-, B, B-, 0, 0-; +5Vcc ou +15...24Vcc pouvant être sélectionné) et came de zéro (C, C-; + 15Vcc ... + 30Vcc)
 - 1 sortie en fréquence répétition codeur TTL (@5V).
-  Erweiterungskarte Digitalencodereingang und Encoderwiederholung:
 - 1 optoisolierte Schnittstelle für Digitalencoder (A, A-, B, B-, 0, 0-; +5 Vdc oder +15...24 Vdc wählbar) und Nocken für Nullstellung (C, C-; 15 Vdc ... 30 Vdc)
 - 1 Frequenzgang für Encoderwiederholung TTL (bei 5 V).
-  Tarjeta de ampliación de entrada de encoder digital y repetición de encoder:
 - 1 interfaz optoaislada para entrada de encoder digital (A, A-, B, B-, 0, 0-; +5Vdc o +15...24Vdc seleccionable) y leva de cero (C, C-; 15Vdc ... 30Vdc).
 - 1 salida de frecuencia repetición encoder TTL (@5V).

Digital Encoder Input Expansion EXP-FIH

Code	Type	Description
S510L	EXP-FIH	Digital encoder input





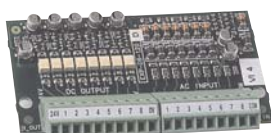

-  Digital encoder input expansion card:
 - 1 optocoupled digital encoder input (A, A-, B, B-; +15...24Vdc).
-  Scheda di espansione ingresso encoder digitale :
 - 1 interfaccia optoisolata per encoder digitale (A, A-, B, B-; +15...24Vdc).
-  Carte d'expansion entrée codeur digital :
 - 1 interface opto-isolée pour codeur digital (A, A-, B, B-; + 15...24Vcc)
-  Erweiterungskarte Digitalencodereingang:
 - 1 optoisolierte Schnittstelle für Digitalencoder (A, A-, B, B-; +15...24 Vdc).
-  Tarjeta de ampliación entrada encoder digital:
 - 1 interfaz optoaislada para encoder digital (A, A-, B, B-; +15...24Vdc).

Digital Input Expansion EXP-D8-120





Code	Type	Description
S520L	EXP-D8-120	Interface card for digital inputs signals at 120VAc



-  Interface card for digital inputs at 120VAc
 - 8 inputs (115VAc ±10%, 50/60Hz, Iinput 4...5.5mA)
 - 8 outputs (24Vdc ±10%, Ioutput 10mA max).
-  Scheda d'interfaccia per ingressi digitali a 120VAc
 - 8 Ingressi (115VAc ±10%, 50/60Hz, Iingresso 4...5,5mA)
 - 8 Uscite (24Vdc ±10%, Iuscita 10mA max).
-  Carte d'interface pour entrées digitale sous 120VAc
 - 8 Entrées (115VAc ±10%, 50/60Hz, Ientrée 4...5,5mA)
 - 8 Sorties (24Vdc ±10%, Isortie 10mA max).
-  Schnittstellenkarte für Digitaleingänge zu 120VAc
 - 8 Eingänge (115VAc ±10%, 50/60Hz, IEingang 4...5,5mA)
 - 8 Ausgänge (24Vdc ±10%, IAusgang 10mA max).
-  Tarjeta interfaz para entradas digitales a 120VAc
 - 8 entradas (115VAc ±10%, 50/60Hz, Iinput 4...5,5mA)
 - 8 salidas (24Vcc ±10%, Ioutput 10mA max).

Resolver interface EXP-RES



Code	Type	Description
S513L	EXP-RES	Resolver interface





-  Resolver interface and TTL digital encoder simulation card:
 - 1 differential resolver input
 - Digital encoder simulation (A, A-, B, B-, I, I-; standard TTL).
-  Scheda interfaccia resolver e simulazione encoder digitale TTL:
 - 1 ingresso differenziale resolver
 - Simulazione encoder digitale (A, A-, B, B-, I, I-; standard TTL).
-  Carte interface résolveur et simulation codeur digital TTL :
 - 1 entrée différentielle résolveur
 - Simulation codeur digital (A, A-, B, B-, I, I-; standard TTL).

-  Schnittstellenkarte Resolver und TTL Digitalencodersimulation:
 - 1 Resolver-Differentialeingang
 - Digitalencodersimulation (A, A-, B, B-, I, I-; Standard TTL).
-  Resolver interface and TTL digital encoder simulation card:
 - 1 differential resolver input
 - Digital encoder simulation (A, A-, B, B-, I, I-; standard TTL).

**Digital I/O Expansion
EXP-D16**



Code	Type	Description
S5R83	EXP-D16	Expansion card for digital inputs and outputs

-  Expansion card for digital inputs and outputs (for sw 2.0 or higher only):
 - 8 optocoupled digital inputs (15...30VDC, Iinput 4.5...9mA)
 - 8 optocoupled digital outputs (15...30VDC, Ioutput 50mA max for any output).
-  Scheda espansione per ingressi e uscite digitali (solo per versione sw 2.0 o superiore):
 - 8 Ingressi digitali optoisolati (15...30Vdc, Iingresso 4,5...9mA)
 - 8 Uscite digitali optoisolate (15...30Vdc, Iuscita 50mA max per ogni uscita).
-  Carte d'expansion pour entrées et sorties digitales (seulement pour version sw 2.0 ou supérieure) :
 - 8 Entrées digitales opto-isolées (15...30Vcc, Ientrée 4,5...9mA)
 - 8 Sorties digitales opto-isolées (15...30Vcc, Isortie 50mA maxi pour chaque sortie).
-  Erweiterungskarte für Digitaleingänge und -ausgänge (nur für SW-Version 2.0 und höher):
 - 8 optoisolierte Digitaleingänge (15...30 VDC, IEingang 4,5...9 mA)
 - 8 optoisolierte Digitalausgänge (15...30 VDC, IAusgang 50 mA max. für jeden Ausgang).
-  Tarjeta de ampliación para entradas y salidas digitales (sólo para versiones sw 2.0 o superiores):
 - 8 Entradas digitales optoaisladas (15...30Vdc, Ientrada 4,5...9mA)
 - Salidas digitales optoaisladas (15...30Vdc, Isalida 50mA máx. para cada salida).

**Special Application Card
APC100y**



Code	Type	Description
S5W02	APC100y	General purpose card

 The programmable APC100y technology card has been designed to meet advanced application requirements where complex management of system variables is required, along with a high processing capacity. The advanced technology used on this card therefore enables the AVy inverter to offer cutting-edge solutions for state-of-the-art industrial control and process systems.

The APC100y card comes as standard with the following predefined application libraries:

- **ELS, standard electrical shaft control (Electric Line Shaft)**
- **TL, standard winding/unwinding control**
Torque control with a closed loop or load cell feedback
- **SD, standard winding/unwinding control**
Speed control with dancer feedback
- **PosMono, standard single-axis positioning device**
 - 64 preconfigurable positions
 - Total encoder management

Based on Gefran-Siei's application experience, another series of libraries can be supplied to users, on request:

- **EPC, lift positioning device**
Version with advanced functionality. For systems with a speed > 1.5 m/s
- **EFC, lift positioning device**
Version with basic functionality. Analogue system speed commands
- **CV, flying shears control**
Controlling flying cutting machines operating in continuous lines
- **RC, rotating shears control**
Controlling flying cutting machines with a rotating blade and the speed synchronised
- **PSACrane / CRCrane, special crane functions**
Special functions for dock cranes (hoisting)
- **TSC, torque control for sheet metal roller-levellers**
Cascade control of machines for roller-levelling and straightening sheet metal

 La scheda tecnologica programmabile APC100y è stata concepita per soddisfare necessità applicative sofisticate, in cui sia necessaria la gestione complessa di variabili di sistema ed un'elevata capacità di calcolo. La tecnologia evoluta utilizzata su questa scheda, permette quindi all'inverter AVy di offrire soluzioni all'avanguardia per i più moderni sistemi industriali di controllo e di processo.

La scheda APC100y fornisce come standard le seguenti librerie applicative predefinite:

- **ELS, Controllo di asse elettrico standard (Electric Line Shaft)**

- **TL, Controllo di avvolgitura/svolgitura standard**
Controllo in coppia ad anello aperto o con retroazione da cella di carico.
- **SD, Controllo di avvolgitura/svolgitura standard**
Controllo in velocità con retroazione da ballerino.
- **PosMono, Posizionatore monoasse standard**
 - 64 posizioni preimpostabili
 - Gestione encoder assoluto

L'esperienza applicativa SIEL mette a disposizione dell'utenza un'ulteriore serie di librerie, disponibili a richiesta:

- **EPC, Posizionatore per ascensori**
Versione con funzionalità evolute. Per impianti con velocità > 1,5 m/s
- **EFC, Posizionatore per ascensori**
Versione con funzionalità base. Comandi analoghi a sistemi in velocità.
- **CV, Controllo di cesoia volante**
Controllo per carri di taglio al volo nelle linee continue
- **RC, Controllo di cesoia rotante**
Controllo di taglio al volo con lama rotante, con sincronizzazione in velocità
- **PSACrane / CRCrane, Funzioni speciali per gru**
Funzionalità speciali per gru portuali (sollevamento)
- **TSC, Controllo di coppia per macchine spianatrici lamiera**
Controllo in cascata di macchine per spianatura/raddrizzamento lamiera



La carte technologique programmable APC100y a été conçue pour répondre aux exigences d'applications sophistiquées nécessitant la gestion complexe de variables de système, ainsi qu'une grande capacité de calcul. La technologie de pointe utilisée sur cette carte, permet donc au variateur AVy d'offrir des solutions à l'avant garde pour les systèmes industriels de contrôle et de procédé, les plus modernes.

La carte APC100y fournit en standard les bibliothèques d'application prédéfinies suivantes :

- **ELS, Contrôle d'axe électrique standard (Electric Line Shaft)**
- **TL, Contrôle d'enroulement/déroulement standard**
Contrôle en couple à boucle ouverte ou avec rétroaction par cellule de chargement
- **SD, Contrôle d'enroulement/déroulement standard**
Contrôle en vitesse avec rétroaction par rouleau libre
- **PosMono, Positionneur à un axe standard**
 - 64 positions pré-configurables
 - Gestion codeur absolu

L'expérience de SIEL dans l'application fournit à l'utilisateur une autre série de bibliothèques, disponibles sur demande :

- **EPC, Positionneur pour ascenseurs**
Version avec fonctionnements de pointe. Pour des installations ayant une vitesse > 1,5 m/s
- **EFC, Positionneur pour ascenseurs**
Version avec fonctionnement de base. Commandes analogiques à systèmes en vitesse.
- **CV, Contrôle de cisaille volante**
Contrôle pour chariot de coupe au vol sur les lignes continues
- **RC, Contrôle de cisaille rotative**
Contrôle de coupe au vol avec lame rotative, avec synchronisation en vitesse
- **PSACrane / CRCrane, Fonctions spéciales pour grues**
Fonctionnements spéciaux pour grues portiques (levage)
- **TSC, Contrôle du couple pour des machines à dresser les tôles**
Contrôle en cascade de machines à dresser/planer les tôles



Die programmierbare Technologiekarte APC100y wurde für komplexe Anwendungen entwickelt, bei denen die Verarbeitung zahlreicher Systemvariablen und hohe Rechenleistung erforderlich ist. Durch die herausragende Technologie dieser Karte ist der Frequenzumrichter AVy in der Lage, fortschrittliche Lösungen für die modernsten Steuerungs- und Prozesssysteme in der Industrie anzubieten.

Die APC100y-Karte liefert als Standard folgende vordefinierte Anwendungsbibliotheken:

- **ELS, Elektrische Welle, bzw. Getriebe (Electric Line Shaft)**
- **TL, Aufwickler / Abwickler**
Drehmomentsteuerung mit offenem Regelkreis oder mit Rückführung durch Lastzelle
- **SD, Aufwickler / Abwickler**
Drehzahlsteuerung mit Tänzerrückführung
- **PosMono, Positioniereinrichtung Standard-Einachse**
 - 64 voreinstellbare Positionen
 - Verwaltung Absoluter Encoder

Dank langjähriger anwendungsbezogener Erfahrung ist SIEL in der Lage, den Benutzern eine weitere Bibliothekenserie zur Verfügung zu stellen, die auf Anfrage erhältlich ist:

- **EPC, Positioniereinrichtung für Aufzüge**
Ausführung mit Funktionen für hohe Ansprüche. Für Anlagen mit einer Geschwindigkeit > 1,5 m/s
- **EFC, Positioniereinrichtung für Aufzüge**
Ausführungen mit Grundfunktionen. Analoge Funktionen wie Drehzahlssysteme
- **CV, Steuerung für fliegende Schere**
Schlittensteuerung für fliegenden Schnitt bei kontinuierlichen Linien

- **RC, Steuerung für Spaltschere**
Steuerung fliegender Schnitt mit Drehklinge, mit Drehzahlsynchronisierung
- **PSACrane / CRCrane, Sonderfunktionen für Kräne**
Sonderfunktionen für Hafenkranne (Hochheben)
- **TSC, Drehmomentsteuerung für Blechrichtmaschinen**
Kaskadensteuerung für Maschinen zum Blechrichten/-planieren

 La tarjeta programable APC100y se ha concebido para satisfacer las necesidades de aplicación sofisticadas, en las que sea necesaria la gestión compleja de variables de sistema y de una elevada capacidad de cálculo. La tecnología avanzada que se utiliza en esta tarjeta, permite al inverter AVy ofrecer soluciones de vanguardia para los más modernos sistemas industriales de control y de proceso.

La tarjeta APC100y dispone como estándar de las siguientes librerías de aplicación predefinidas:

- **ELS, Control de eje eléctrico estándar (Electric Line Shaft)**
- **TL, Control de enrollado / desenrollado estándar**
Control de par en anillo abierto o con retroacción de celda de carga.
- **SD, Control de enrollado / desenrollado estándar**
Control de velocidad con retroacción de rodillo.
- **PosMono, Posicionador monoeje estándar**
- 64 posiciones predefinidas
- Gestión encoder absoluto





La experiencia en aplicaciones de SIEL pone a disposición del usuario un conjunto de librerías adicionales, que se suministran bajo pedido:

- **EPC, Posicionadores para ascensores**
Versiones con funcionalidades avanzadas. Para velocidades > 1,5 m/s
- **EFC, Posicionadores para ascensores**
Versiones con funcionalidades básicas. Comandos analógicos en sistemas de velocidad
- **CV, Control de cizalla volante**
Control para carros de corte al vuelo en líneas continuas
- **RC, Control de cizalla giratoria**
Control de cote al vuelo con cuchilla giratoria, con sincronización en velocidad
- **PSACrane / CRCrane, Funciones especiales para grúas**
Funcionalidades especiales para grúas portuarias (elevación)
- **TSC, Control de par para máquinas laminadoras**
Control en cascada de máquinas para laminadoras / enderezadoras

Absolute encoder interface E-ABS







Code	Type	Description
S512L	E-ABS	Absolute encoder interface

-  Absolute encoder reading with SSI protocol to be installed on APC100y.
-  Lettura encoder assoluto con protocollo SSI per montaggio su APC100y.
-  Lecture codeur absolu avec protocole SSI pour montage sur APC100y.
-  Lesen absoluter Encoder mit SSI Protokoll für Montage auf APC100y.
-  Lectura encoder absoluto con protocolo SSI para montaje en APC100y.

Safety card EXP-SFTy





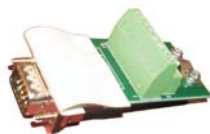

Code	Type	Description
On request	Mounting EXP-SFTy	Mounting of Safety cards (from 22kW to 132kW sizes)

-  Safety card for disabling IGBT module control, in accordance with the standard "Prevention of unexpected start-up" EN 1037:1995.
Option to be **installed in factory**, on request, for all AVy ranges.
-  Scheda di sicurezza per esclusione comando moduli IGBT, conforme alla normativa "prevention of unexpected start-up" EN 1037:1995.
Opzione a richiesta da **montare in fabbrica** per tutte linee AVy.
-  Carte de sécurité pour l'exclusion de la commande des modules IGBT, conforme à la norme "prevention of unexpected start-up" EN 1037:1995.
Option sur demande, à **monter en usine** pour toutes les lignes AVy.
-  Sicherheitskarte für den Ausschluss der IGBT Modul-Befehle, entsprechend der EN 1037:1995 „Vermeidung von unerwartetem Anlauf“.
Option auf Anfrage, die für alle AVy-Serien **werkseitig zu montieren** ist.
-  Tarjeta de seguridad para exclusión del comando del módulo IGBT, en cumplimiento de la normativa "prevention of unexpected start-up" EN 1037:1995.
Opción de **montaje en fábrica** bajo pedido para toda la línea AVy.

Encoder interface
ENC-ADPT



Code	Type	Description
S5D03	ENC-ADPT	Connector / terminals encoder interface.

-  *Interfaccia connettore / morsetti per encoder.*
-  *Interface connecteur / bornes pour codeur.*
-  *Schnittstelle Steckverbinder / Klemmen für Encoder.*
-  *Interfaz conectores / bornes por encoder.*

Field Bus Interface

Interfaccia bus di campo
Interface bus de terrain
Feldbus-Schnittstelle
Interfaces de Bus de campo

Profibus-DP Interface SBI-PDP-33







Code	Type	Description
S5H44	SBI-PDP-33	Field bus interface
S54H4	SBI-PDP-33-SA	Stand Alone Field bus interface

-  - ProfiBus-DP protocol
- Transmission speed: autoselect from 9.6 kbit/s to 12 Mbit/s
- Bus address: 1...127, selectable via DIP switches
- Data frame: configuration channel towards all the drive parameters; 4 I/O fast word for rapid access
- Sync and Freeze supported.
-  - Protocollo ProfiBus-DP
- Velocità di trasmissione: selezione automatica da 9,6 kbit/s a 12Mbit/s
- Indirizzo Bus: 1...127, selezione tramite DIP-switch
- Data frame: canale di configurazione per accedere a tutti i parametri del drive; 4 I/O fast word per accesso veloce
- Supporto Sync e Freeze.
-  - Protocole ProfiBus-DP
- Vitesse de transmission : Sélection automatique de 9,6 kbit/s à 12Mbit/s
- Adresse Bus : 1 ... 127, sélection par DIP-switch
- Data frame : canal de configuration pour accéder à tous les paramètres du drive ; 4 E/S fast word pour accès rapide
- Support Sync et Freeze.
-  - ProfiBus-DP Protokoll
- Übertragungsgeschwindigkeit: automatische Wahl von 9,6 kbit/s bis 12Mbit/s
- Bus-Adresse: 1...127, Wahl mit DIP-Schalter
- Data frame: Konfigurationskanal für den Zugriff auf alle Antriebsparameter; 4 fast word I/O für raschen Zugriff
- Unterstützt Sync und Freeze.
-  - Protocollo ProfiBus-DP
- Velocidad de transmisión: selección automática de 9,6 kbit/s a 12Mbit/s
- Dirección bus: 1 ... 127, selección por medio de conmutadores DIP
- Marco de datos: canal de configuración para acceder a todos los parámetros del drive; 4 E/S fast word para acceso rápido.
- Soporte Sync y Freeze.

DeviceNet Interface SBI-DN-33



Code	Type	Description
S5Z29	SBI-DN-33	Field bus interface
S54H5	SBI-DN-33-SA	Stand Alone Field bus interface

-  - DeviceNet protocol
- Transmission speed: 125, 250, 500 kbit/s, selectable via DIP switches
- Bus address: 1...63, selectable via DIP switches
- Data frame: Explicit messaging towards all the drive parameters; 1...6 I/O polling word for rapid access, selectable via DIP switch.
-  - Protocollo DeviceNet
- Velocità di trasmissione: 125, 250, 500 kbit/s, selezione tramite DIP-switch
- Indirizzo Bus: 1...63, selezione tramite DIP-switch
- Data frame: Explicit Messaging per accedere a tutti i parametri del drive; 1...6 Polling I/O word per accesso veloce, selezione tramite DIP-switch.
-  - Protocole DeviceNet
- Vitesse de transmission : 125, 250, 500 kbit/s, sélection par DIP-switch
- Adresse Bus : 1 ... 63, sélection par DIP-switch
- Data frame : Explicit Messaging pour accéder à tous les paramètres du drive ; 1...6 Polling E/S word pour accès rapide, sélection par DIP-switch.
-  - DeviceNet Protokoll
- Übertragungsgeschwindigkeit: 125, 250, 500 kbit/s, Wahl mit DIP-Schalter
- Bus-Adresse: 1...63, Wahl mit DIP-Schalter
- Data frame: Explicit Messaging für den Zugriff auf alle Antriebsparameter; 1...6 Polling word I/O für raschen Zugriff, Wahl mit DIP-Schalter.

-  - Protocolo DeviceNet
- Velocidad de transmisión: 125, 250, 500 kbits/s, selección por medio de conmutadores DIP
- Dirección bus: 1 ... 63, selección por medio de conmutadores DIP
- Marco de datos: Explicit Messaging para acceder a todos los parámetros del drive; 1 ... 0,6 polling I/O word para acceso rápido, selección por medio de conmutadores DIP

**CANopen Interface
SBI-COP-33**

Code	Type	Description
S5Z42	SBI-COP-33	Field bus interface
S5Z43	SBI-COP-33-SA	Stand Alone Field bus interface



-  Field bus interface:
 - ProfiBus-DP protocol
 - Transmission speed: up to 1 Mbit/s, selectable via DIP switches
 - Data frame: 1 SDO towards all the drive parameters, 2 PDO with 4 I/O word for rapid access
 - Bus address: 1...128, selectable via DIP switches.

-  Interfaccia bus di campo:
 - Protocollo CANopen
 - Velocità di trasmissione: fino a 1 Mbit/s, selezione tramite DIP-switch
 - Data frame: 1 SDO per accedere a tutti i parametri del drive, 2 PDO di 4 I/O word per accesso veloce
 - Indirizzo Bus: 1...128, selezione tramite DIP-switch.

-  Interface bus de terrain :
 - Protocole CANopen
 - Vitesse de transmission : jusqu'à 1 Mbit/s, sélection par DIP-switch
 - Data frame : 1 SDO pour accéder à tous les paramètres du drive, 2 PDO de 4 E/O word pour accès rapide
 - Adresse Bus : 1 ... 128, sélection par DIP-switch

-  Feldbus-Schnittstelle:
 - CANopen Protokoll
 - Übertragungsgeschwindigkeit: bis zu 1 Mbit/s, Wahl mit DIP-Schalter
 - Data frame: 1 SDO für den Zugriff auf alle Antriebsparameter, 2 PDO mit 4 word I/O für raschen Zugriff
 - Bus-Adresse: 1...128, Wahl mit DIP-Schalter.

-  Interfaz bus de campo:
 - Protocolo CANopen
 - Velocidad de transmisión: hasta 1 Mbit/s, selección por medio de conmutadores DIP
 - Marco de datos: 1 SDO para acceder a todos los parámetros del drive; 2 PDO de 4 I/O word para acceso rápido
 - Dirección bus: 1 ... 128, selección por medio de conmutadores DIP

**DeviceNet Interface
(for APC100y card)
DNET-1**

Code	Type	Description
S579H	DNET-1	Field bus interface (insertion on APC100y card)



-  - DeviceNet protocol
 - Transmission speed: 125, 250, 500 kbit/s, selectable via DIP switches
 - Bus address: 1...63, selectable via DIP switches
 - Data frame: Explicit messaging towards all the drive parameters, 1...6 I/O polling word for rapid access, selectable via DIP switch.

-  - Protocollo DeviceNet
 - Velocità di trasmissione: 125, 250, 500 kbit/s, selezione tramite DIP-switch
 - Indirizzo Bus: 1...63, selezione tramite DIP-switch
 - Data frame: Explicit Messaging per accedere a tutti i parametri del drive, 1...6 Polling I/O word per accesso veloce, selezione tramite DIP-switch.

-  - Protocole DeviceNet
 - Vitesse de transmission : 125, 250, 500 kbit/s, sélection par DIP-switch
 - Adresse Bus : 1 ... 63, sélection par DIP-switch
 - Data frame : Explicit Messaging pour accéder à tous les paramètres du drive, 1...6 Polling E/S word pour accès rapide, sélection par DIP-switch.



- DeviceNet Protokoll
- Übertragungsgeschwindigkeit: 125, 250, 500 kbit/s, Wahl mit DIP-Schalter
- Bus-Adresse: 1...63, Wahl mit DIP-Schalter.
- Data frame: Explicit Messaging für den Zugriff auf alle Antriebsparameter, 1...6 Polling word I/O für raschen Zugriff, Wahl mit DIP-Schalter.



- Protocolo DeviceNet
 - Velocidad de transmisión: 125, 250, 500 kbits/s, selección por medio de conmutadores DIP
 - Dirección bus: 1 ... 63, selección por medio de conmutadores DIP
 - Trama de datos: Explicit Messaging para acceder a todos los parámetros del drive; 1 ... 6 Polling I/O word para acceso rápido, selección por medio de conmutadores DIP
-

Any information or suggestions that could help us to improve this catalogue are always welcome. Please send your comments to our e-mail address at techdoc@siei.it. GEFRAN S.p.A. has a policy of the continuous improvement of performance and range of our products and therefore the Company retains the right to modify products, data and dimensions without notice. Although the data and information contained in this document is as accurate as we can make it, it is intended to be used for product description purposes only and must not be interpreted as being legally declared specifications. All rights reserved.

Saremo lieti di ricevere all'indirizzo e-mail: techdoc@siei.it qualsiasi informazione che possa aiutarci a migliorare questo catalogo.

La GEFRAN S.p.A. si riserva la facoltà di apportare modifiche e varianti a prodotti, dati, dimensioni, in qualsiasi momento senza obbligo di preavviso.

I dati indicati servono unicamente alla descrizione dei prodotti e non devono essere intesi come proprietà assicurata nel senso legale.

Tutti i diritti riservati.

Nous serons heureux de recevoir à l'adresse: techdoc@siei.it toute information pouvant nous aider à améliorer ce catalogue.

GEFRAN S.p.A. se réserve le droit d'apporter des modifications et des variations aux produits, données et dimensions, à tout moment et sans préavis.

Les informations fournies servent uniquement à la description des produits et ne peuvent en aucun cas revêtir un aspect contractuel.

Tous les droits sont réservés.

Wir würden uns freuen, wenn Sie uns Informationen, die zur Verbesserung dieses Katalogs beitragen können, an folgende E-Mail-Adresse schicken würden: techdoc@siei.it.

GEFRAN S.p.A. behält sich das Recht vor, ohne Verpflichtung zur Vorankündigung an Produkten, Daten und Abmessungen jederzeit Änderungen oder Varianten vorzunehmen.

Die angeführten Daten dienen lediglich der Produktbeschreibung und dürfen nicht als garantierte Eigenschaften im rechtlichen Sinne verstanden werden.

Alle Rechte vorbehalten.

Estaremos encantados de recibirlos en la dirección de e-mail techdoc@siei.it para cualquier información que pueda contribuir a mejorar este manual.

GEFRAN S.p.A se reserva el derecho de realizar modificaciones y variaciones sobre los productos, datos o medidas, en cualquier momento y sin previo aviso.

Los datos indicados están destinados únicamente a la descripción de los productos y no deben ser contemplados como propiedad asegurada en el sentido legal.

Todos los derechos reservados.

GEFRAN SENSORI

via Cave, 11
25050 PROVAGLIO D'ISEO (BS) ITALY
Ph. +39 030 9291411
Fax. +39 030 9823201
info@gefran.com

GEFRAN BENELUX

Lammerdries, 14A
B-2250 OLEN
Ph. +32 (0) 14248181
Fax. +32 (0) 14248180
info@gefran.be

**GEFRAN BRASIL
ELETRÔELETRÔNICA**

Avenida Dr. Altino Arantes,
377/379 Vila Clementino
04042-032 SÃO PAULO - SP
Ph. +55 (0) 1155851133
Fax +55 (0) 1155851425
gefran@gefran.com.br

GEFRAN DEUTSCHLAND

Philipp-Reis-Straße 9a
63500 SELIGENSTADT
Ph. +49 (0) 61828090
Fax +49 (0) 6182809222
vertrieb@gefran.de

GEFRAN SUISSE SA

Fritz-Courvoisier 40
2302 La Chaux-de-Fonds
Ph. +41 (0) 329684955
Fax +41 (0) 329683574
office@gefran.ch

GEFRAN SIEI - FRANCE

4, rue Jean Desparmet - BP 8237
69355 LYON Cedex 08
Ph. +33 (0) 478770300
Fax +33 (0) 478770320
commercial@gefran.fr
contact@sieifrance.fr

GEFRAN INC

Automation and Sensors
8 Lowell Avenue
WINCHESTER - MA 01890
Toll Free 1-888-888-4474
Ph. +1 (781) 7295249
Fax +1 (781) 7291468
info@gefranisi.com

GEFRAN INC

Motion Control
14201 D South Lakes Drive
NC 28273 - Charlotte
Ph. +1 704 3290200
Fax +1 704 3290217
salescontact@sieiamerica.com

SIEI AREG - GERMANY

Zachersweg, 17
D 74376 - Gemmingheim
Ph. +49 7143 9730
Fax +49 7143 97397
info@sieiareg.de

GEFRAN SIEI - UK

7 Pearson Road, Central Park
TELFORD, TF2 9TX
Ph. +44 (0) 8452 604555
Fax +44 (0) 8452 604556
sales@gefran.co.uk
sales@sieiuk.co.uk

GEFRAN SIEI - ASIA

No.160 Paya Lebar Road
05-07 Orion Industrial Building
409022 Singapore
Ph. +65 6 8418300
Fax +65 6 7428300
info@sieiasia.com.sg

GEFRAN SIEI Electric (Shanghai) Pte Ltd

Block B, Gr.Flr, No.155, Fu Te Xi Yi Road,
Wai Gao Qiao Trade Zone
200131 Shanghai
Ph. +86 21 5866 7816
Ph. +86 21 5866 1555
Ph. +86 21 5866 7688
gefransh@online.sh.cn

SIEI DRIVES TECHNOLOGY

No.1265, B1, Hong De Road,
Jia Ding District
201821 Shanghai
Ph. +86 21 69169898
Fax +86 21 69169333
info@sieiasia.com.cn

AUTHORIZED DISTRIBUTORS

- | | |
|----------------|----------------------|
| Argentina | Saudi Arabia |
| Austria | Singapore |
| Australia | Slovakia Republic |
| Brasil | Slovenia |
| Bulgaria | South Africa |
| Canada | Spain |
| Chile | Sweden |
| Cyprus | Taiwan |
| Colombia | Thailand |
| Czech Republic | Tunisia |
| Denmark | Turkey |
| Egypt | Ukraine |
| Finland | United Arab Emirates |
| Greece | Venezuela |
| Hong Kong | |
| Hungary | |
| India | |
| Iran | |
| Israel | |
| Japan | |
| Jordan | |
| Korea | |
| Lebanon | |
| Malaysia | |
| Maroc | |
| Mexico | |
| New Zealand | |
| Norway | |
| Peru | |
| Poland | |
| Portugal | |
| Rumania | |
| Russia | |



GEFRAN S.p.A.

Via Sebina 74
25050 Provaglio d'Iseo (BS) ITALY
Ph. +39 030 98881
Fax +39 030 9839063
info@gefran.com
www.gefran.com

Motion Control

Via Carducci 24
21040 Gerenzano [VA] ITALY
Ph. +39 02 967601
Fax +39 02 9682653
info@siei.it
www.gefransiei.com

Technical Assistance :
technohelp@siei.it

Customer Service :
customer@siei.it
Ph. +39 02 96760500
Fax +39 02 96760278



Certificate No. FM 38167

ARTDrive Avy Catalogue
rev. 0.2 - 13.4.07



1S9180