

The KE Series are for use in high temperature applications where the process temperatures may reach 538°C (1000°F) such as high temperature engineered polymers. The K Series utilizes standard melt pressure principles and construction, but uses a near incompressible NaK (Sodium Potassium) for pressure transmission. The K Series strain sensing technology is bonded foil strain gage.

MAIN FEATURES

- Pressure ranges from:
0-35 to 0-1000 bar / 0-500 to 0-15000 psi
- Accuracy: $< \pm 0.25\%$ FSO (H); $< \pm 0.5\%$ FSO (M)
- Hydraulic transmission system for pressure signal guarantees stability at working temperature (NaK). Liquid conforming to RoHS Directive. NaK is defined as a safe substance (GRAS)
- Quantity of NaK contained per model: KE0 series (30mm³) [0.00183 in³], KE1, KE2, KE3 (40mm³) [0.00244 in³]
- 1/2-20UNF, M18x1.5 standard threads; other types available on request
- Autozero function on board / external option
- Stem drift Autocompensation function (SP version)
- Inconel 718 diaphragm with GTP coating for temperatures up to 538°C (1000°F)
- 15-5 PH diaphragm with GTP coating for temperatures up to 400°C (750°F)
- Hastelloy C276 diaphragm for temperatures up to 300°C (570°F)
- 17-7 PH corrugated diaphragm with GTP coating for ranges below 100bar-1500psi
- Stem material: 17-4 PH

GTP (advanced protection)

Coating with high resistance against corrosion, abrasion and high temperature

AUTOZERO FUNCTION

All signal variations in the absence of pressure can be eliminated by using the Autozero function.

This function is activated by closing a magnetic contact located on the transmitter housing.

The procedure is permitted only with pressure at zero.

AUTO-COMPENSATED INFLUENCE OF MELT TEMPERATURE

Thanks to internal self-compensation, the KSP series transmitter cancels the effect of pressure signal variation caused by variation of Melt temperature.

This reduces at the minimum the read error caused by heating of the filling fluid (typical of all sensors built with "filled" technology).

The drift values declared in the version with Autocompensation are valid for media temperatures up to 500°C.

TECHNICAL SPECIFICATIONS

Accuracy (1)	H $< \pm 0.25\%$ FSO (100...1000 bar) M $< \pm 0.5\%$ FSO (35...1000 bar)
Resolution	Infinite
Measurement range	0..35 a 0..1000bar 0..500 a 0..15000psi
Maximum overpressure (without degrading performances)	2 x FS 1.5 x FS over 1000bar/15000psi
Measurement principle	Extensimetric
Power supply	10...30Vdc
Maximum current absorption	32mA
Insulation resistance (at 50Vdc)	>1000 MOhm
Output signal Full Scale FSO	20mA
Zero balance (tolerance $\pm 0.25\%$ FSO)	4mA
Zero signals adjustment (tolerance $\pm 0.25\%$ FSO)	"Autozero" function
Span adjustment within $\pm 5\%$ FSO	See Melt Manual
Maximum allowed load	See chart
Electronic response time (10...90% FSO)	~ 1ms
Output noise (RMS 10-400Hz)	< 0.025% FSO
Calibration signal	80% FSO
Output short circuit and reverse polarity protection	YES
Compensated temperature range	0...+85°C
Operating temperature range	-30...+105°C
Storage temperature range	-40...+125°C
Thermal drift in compensated range: Zero / Calibration / Sensibility	< 0.02% FSO/°C
Diaphragm maximum temperature	538°C/1000°F
Zero drift (zero)	< 3,5bar/100°C / < 28 psi/100°F
Zero drift temperature for Autocompensated version (SP) within the temperature range 20°C-500°C inclusive the drift temperature of the housing	< 0.005 bar/°C 100 \leq p < 500 bar 0.0022 %FS/°C p \geq 500 bar
Thermocouple (model KE2)	STD : type "J" (isolated junction)
Protection degree (with 6-pole female connector)	IP65

FSO = Full Scale Output

(1) BFSL method (Best Fit Straight Line): includes combined effects of Non-Linearity, Hysteresis and Repeatability.

MECHANICAL DIMENSIONS

KE0

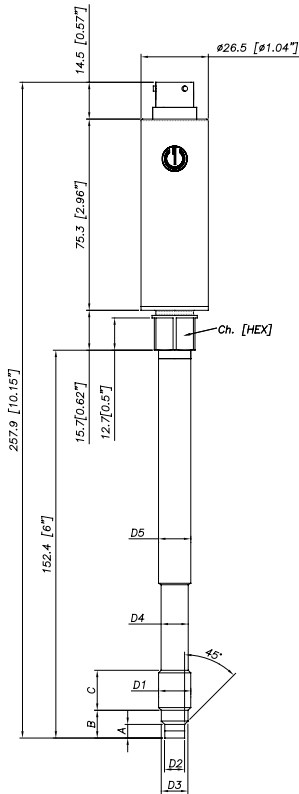

D1	1/2 - 20UNF
D2	$\phi 7.8 - 0.05$ [$\phi 0.31'' - 0.002$]
D3	$\phi 10.5 - 0.025$ [$\phi 0.41'' - 0.001$]
D4	$\phi 10.67$ [$\phi 0.42''$]
D5	$\phi 12.7$ [$\phi 0.5''$]
A	5.56 - 0.26 [0.22'' - 0.01]
B	11.2 [0.44'']
C	15.74 [0.62'']
Ch [Hex]	16 [5/8'']

KE2

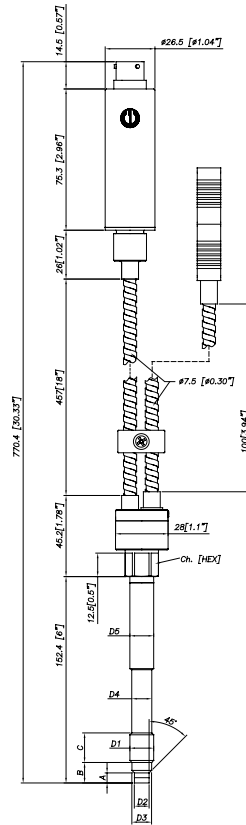

KE1

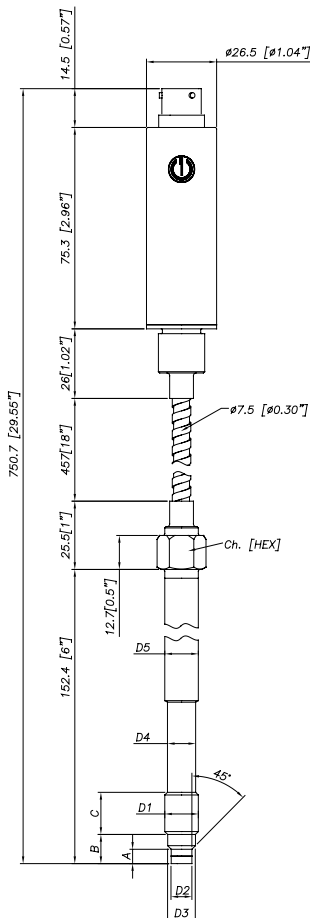

D1	M18x1.5
D2	$\phi 10 - 0.05$ [$\phi 0.394'' - 0.002$]
D3	$\phi 16 - 0.08$ [$\phi 0.63'' - 0.003$]
D4	$\phi 16 - 0.4$ [$\phi 0.63'' - 0.016$]
D5	$\phi 18$ [$\phi 0.71''$]
A	6 - 0.26 [0.24'' - 0.01]
B	14.8 - 0.4 [0.58'' - 0.016]
C	19 [0.75'']
Ch [Hex]	19 [3/4'']

KE3

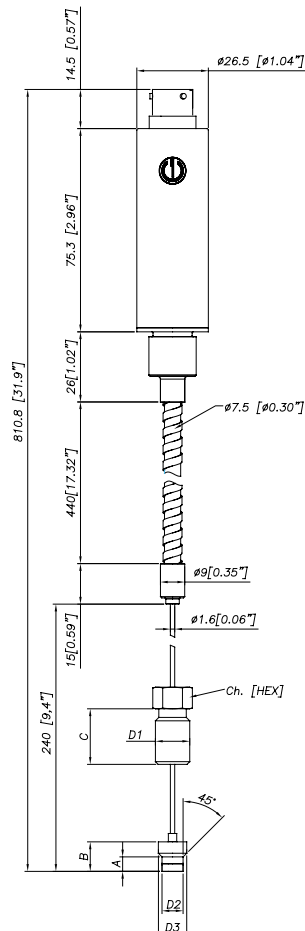

Exposed capillary	
D1	1/2-20UNF
D2	.307/.305" [7.80/7.75mm]
D3	.414/.412" [10.52/10.46mm]
A	.125/.120" [3.18/3.05mm]
B	.318/.312" [8.08/7.92mm]
C	.81" [20.6mm]

NOTE : dimensions refer to rigid stem length option "4" (153 mm – 6")

WARNING : For installation use a maximum tightening torque of 56 Nm(500 in-lb)

ELECTRICAL CONNECTIONS

CURRENT OUTPUT (4...20mA, 2 wires)

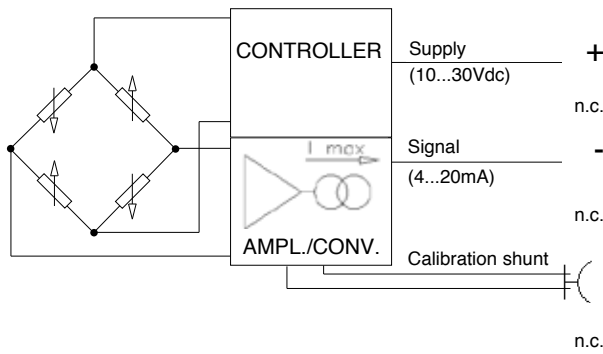

MAGNETIC AUTOZERO

6-pin	8-pin
A	B
C	A
B	D
D	C
E - F	E - F
	G - H

EXTERNAL AUTOZERO

6-pin	8-pin
A	B
C	A
B	D
D	C
E - F	E - F
	G - H

Connect the cable sheathing to the side of the instrument

LOAD DIAGRAM

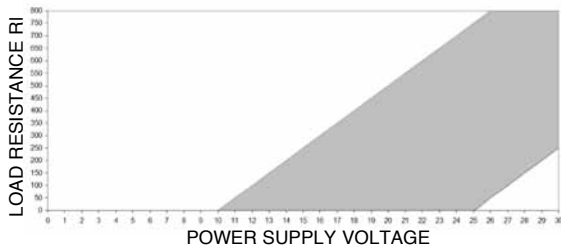

The diagram shows the optimum ratio between load and power supply for transmitters with 4...20mA output. For correct function, use a combination of load resistance and voltage that falls within the shaded area.

AUTOZERO FUNCTION

6-pin connector
VPT07RA10-6PT2
(PT02A-10-6P)

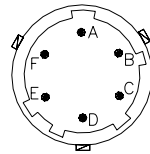

8-pin connector
PC02E-12-8P Bendix

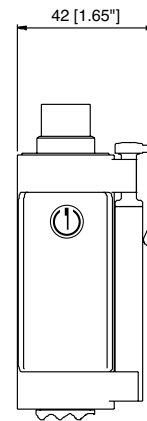
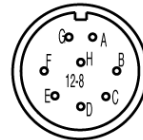

The Autozero function is activated through a magnetic contact (external magnet supplied with the sensor). See the manual for a complete Autozero function explanation.

ACCESSORIES

Connectors

6-pin female connector (IP65 protection degree)
8-pin female connector

Extension cables

6-pin connector with 8m (25 ft) cable
6-pin connector with 15m (50 ft) cable
6-pin connector with 25m (75 ft) cable
6-pin connector with 30m (100 ft) cable
8-pin connector with 8m (50 ft) cable
8-pin connector with 25m (75 ft) cable
8-pin connector with 30m (100 ft) cable
Other lengths

Accessories

Mounting bracket
Dummy plug for 1/2-20 UNF
Dummy plug for M18x1,5
Drill kit for 1/2 -20 UNF
Drill kit for M18 x 1,5
Cleaning kit for 1/2-20 UNF
Cleaning kit for M18x1,5
Fixing pen clip
Autozero pen

Thermocouple for KE2 model

Type "J" (153mm - 6" rigid stem)

CON300
CON307

C08WLS
C15WLS
C25WLS
C30WLS
E15WLS
E25WLS
E30WLS
on request

SF18
SC12
SC18
KF12
KF18
CT12
CT18
PKIT309
PKIT312

TTER601

Cable color code

Conn.	Wire
A	Red
B	Black
C	White
D	Green
E	Blue
F	Orange

