



IN Sensor with magnetic base „S“

Main features:

- Measurements up to 4000bar nozzle pressure and melt temperature of 400°C.
- Multishot measurements at temperatures <230°C with different levels of pressure.
- Simple magnetic installation without screws.
- Combine the IN Sensor together with the Nozzle touch force sensor.
- Ideal for service and development (measurements during operation are not possible).
- Scope of delivery: IN Sensor, Controle and display device, Heater band, Nozzle adapter, Magnetic adapter, Magnetic base and carrying case.

The IN Sensor measure in the injection moulding machine the nozzle pressure compare to the injection pressure. This is especially important in processes according to ISO9000. The Nozzle pressure sensor is mounted with magnetic force.

The nozzle injector of the injection moulding machine press directly on the nozzle adapter which protects the sensor against damage. After that the IN Sensor will be loaded with the melt of the injection pressure. The Heater band warms the IN Sensor up to 230°C so that the melt in the conical chamber remains liquide. This allows multiple measurements with different injection pressure.

TECHNICAL DATA

Strain gauge type	Foil
Measuring range	4000bar
Maximum touch force	300kN (@ 60 mm diameter)
Sensitivity	1.5 mV/V (nominal)
Combined error	< ± 1% FS
Linearity	< ± 0.5% FS
Hysteresis	< ± 0.1% FS
Repeatability	< ± 0.1% FS
Operating temperatur range	10°...+230°C (up to 400°C with singleshot application)
Storage temperatur range	-20°...+70°C
Protection class	IP65
Case material	Stainless steel (high grade)

APPLICATION

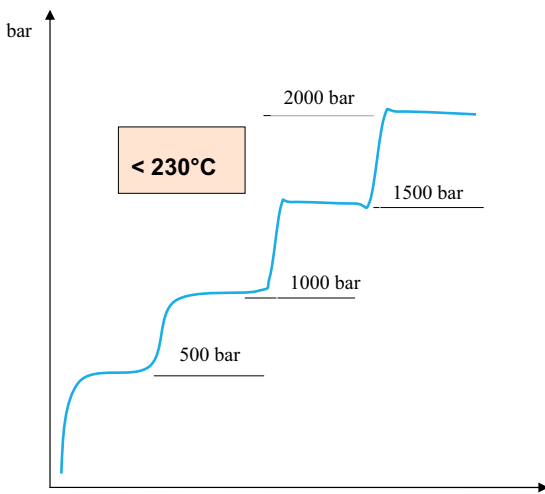
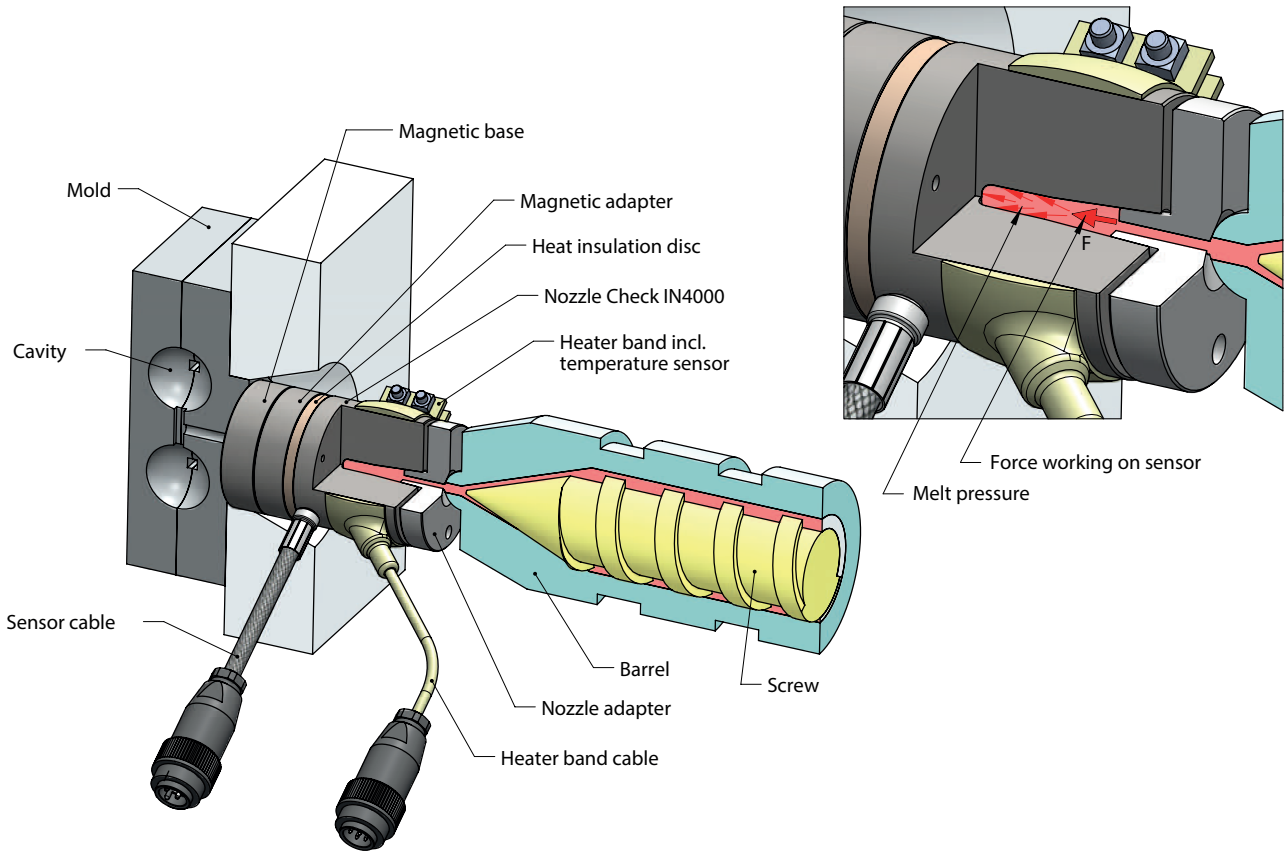

MULTISHOT

- Measure melt pressures up to 230°C and 4000bar
- Plastic does NOT solidify during pressure steps
- Nozzle pressure is transmitted through plastic onto the measuring element

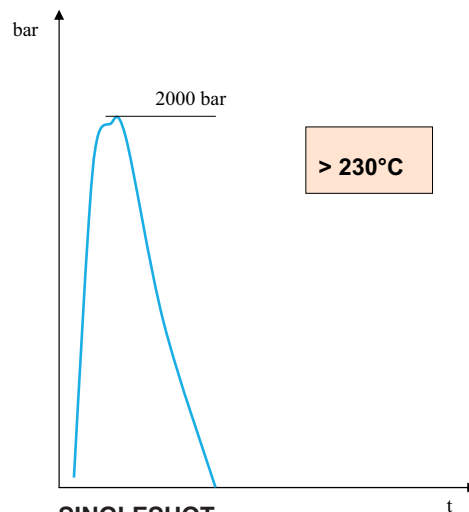

SINGLESHOT

- For melt temperatures > 230°C (up to 400°C)
- One shot only, then solidification
- Plastic has to be removed every shot

DIMENSION

IN Sensor with heat insulation disc and magnetic adapter

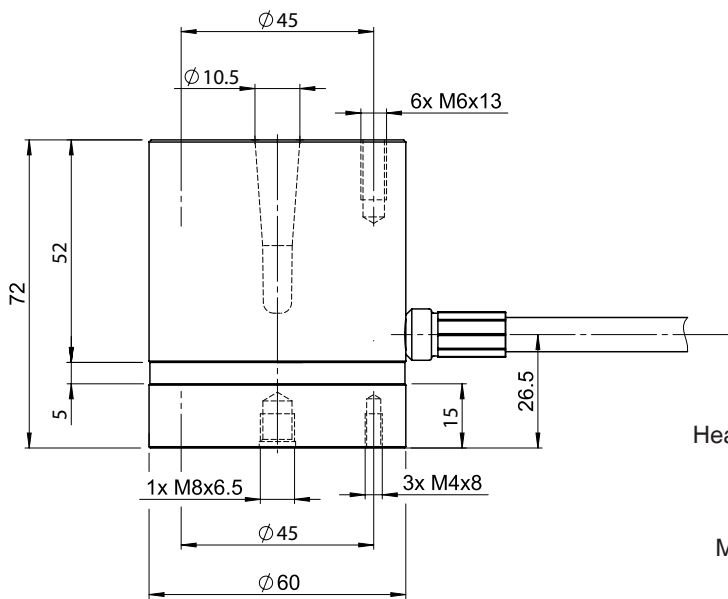

Exempel: Assembly drawing

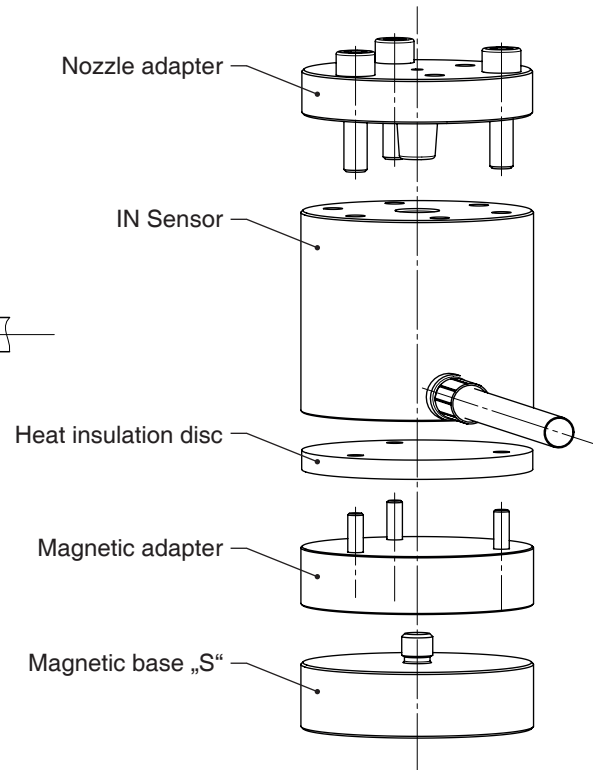

Dimensions in mm

STANDARD ASSESSORIES

Nozzle adapter NA-IN-2

The nozzle adapter protects the IN Sensor and the tip of the nozzle can be optimally adapted. The nozzle adapter is by the customers themselves adapted to the respective nozzle tip of the injection molding machine. The raw diameter is 3mm.

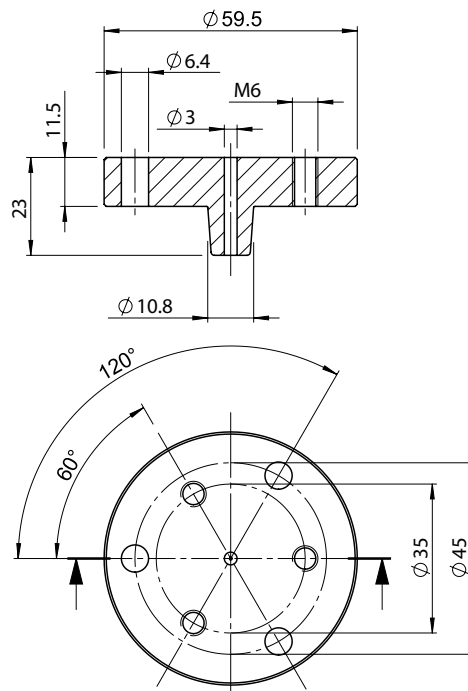

Dimensions in mm

Monitor

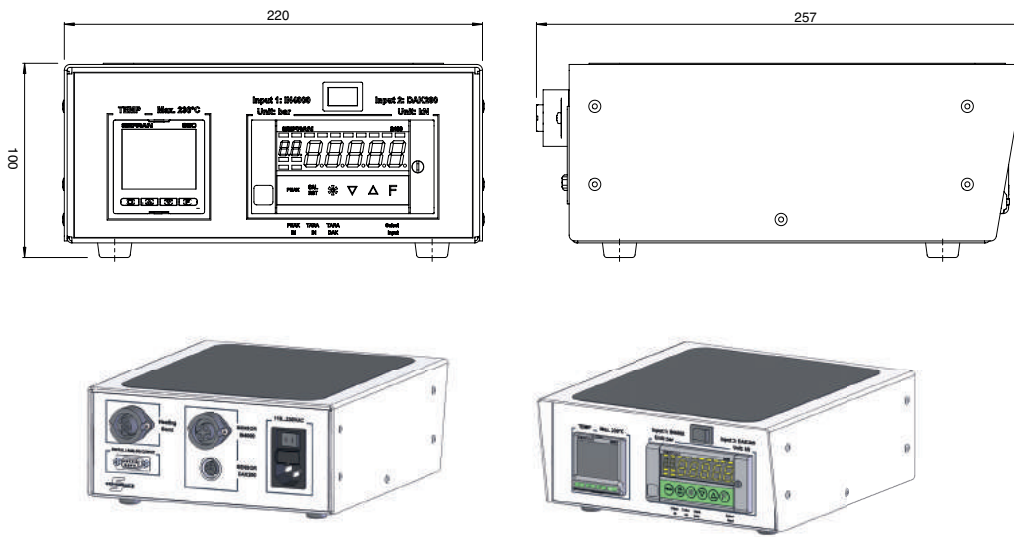

Dimensions in mm

OPTIONAL ACCESSORIES

Magnetic base „S“ 60mm

The magnetic base with \varnothing 60mm contains 1 magnet.

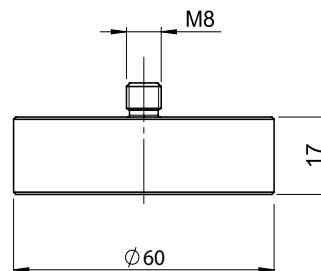

Dimensions in mm

Magnetic base „H“ 100mm

The magnetic base with \varnothing 100mm contains 3 magnets.
Three screws M6 helps to remove the magnetic base from the machine.

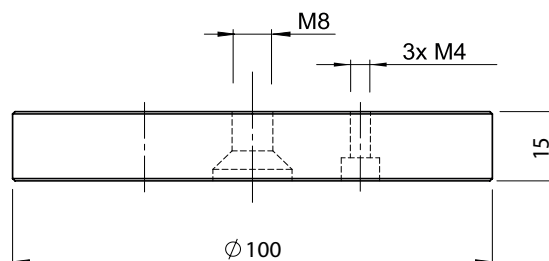

Dimensions in mm

MONITOR DESCRIPTION

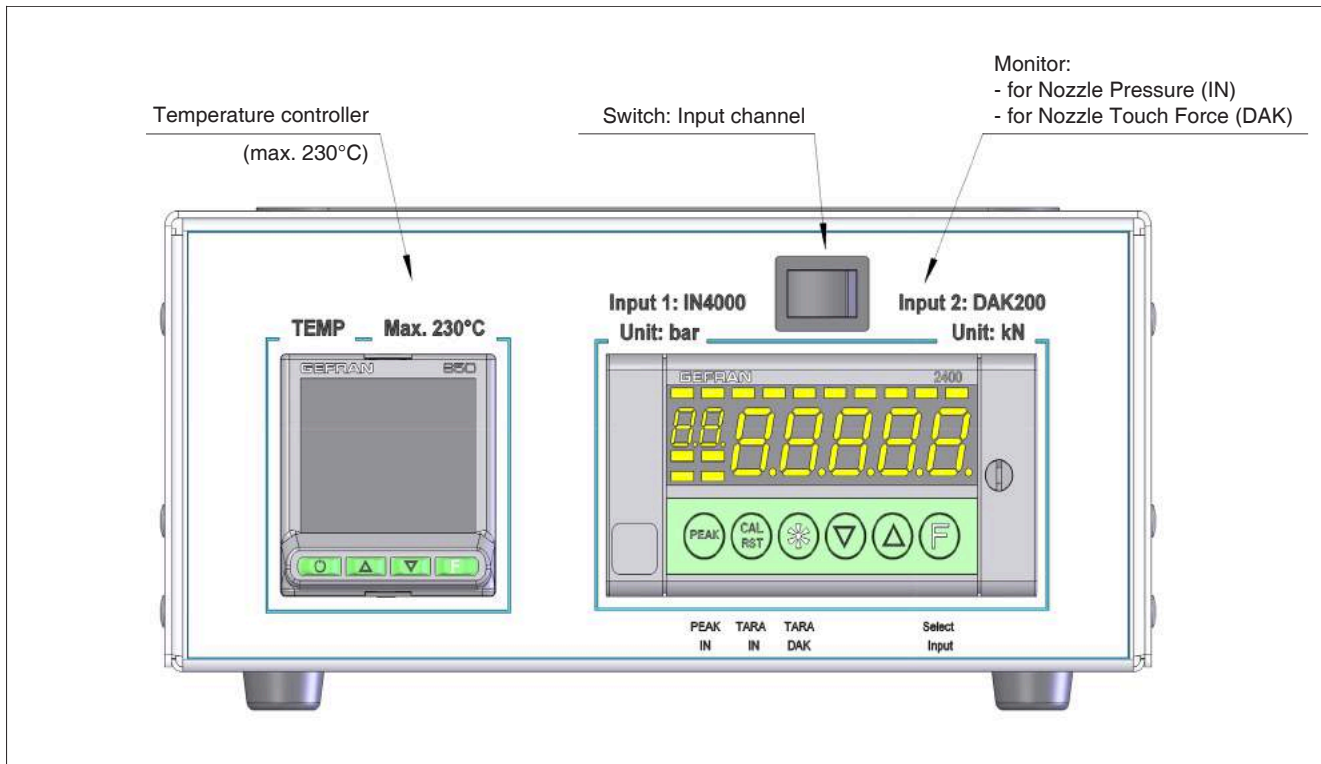

ELECTRICAL CONNECTIONS

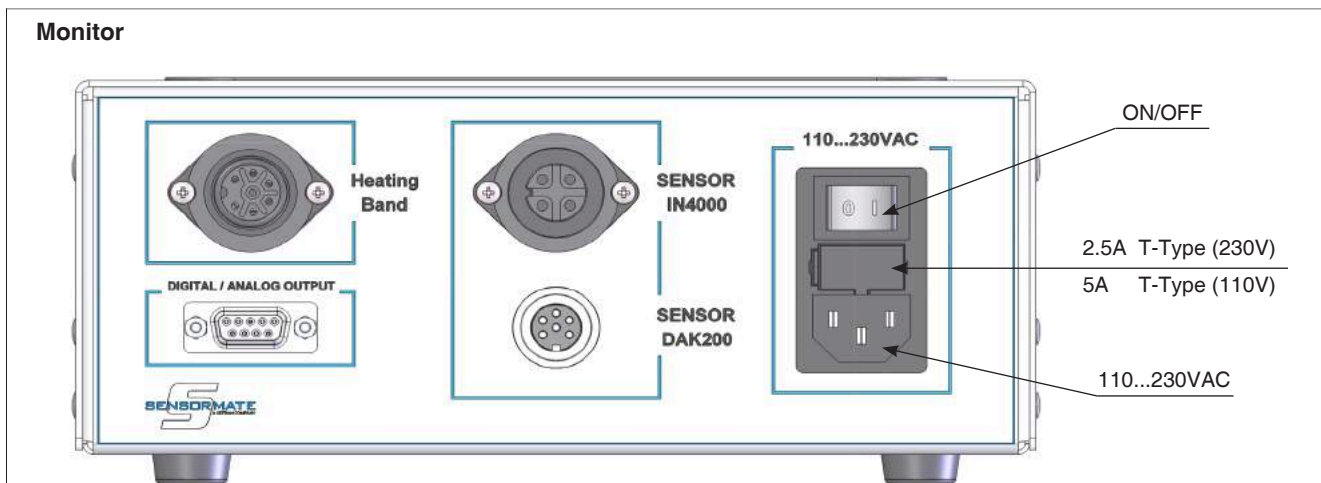

IN sensor input

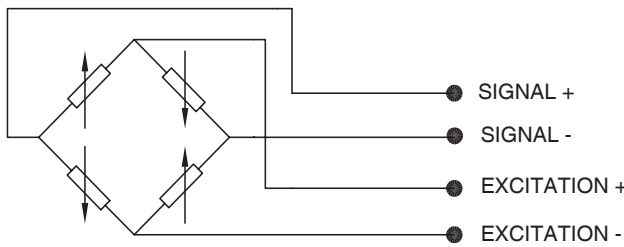
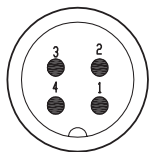

CONNECTOR

SIGNAL +	2
SIGNAL -	3
EXCITATION +	1
EXCITATION -	4

DAK sensor input

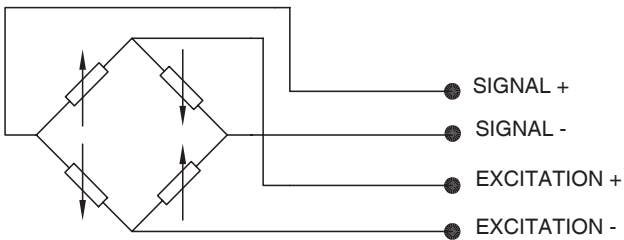
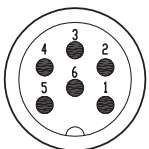

CONNECTOR

SIGNAL +	4
SIGNAL -	5
EXCITATION +	1-2
EXCITATION -	3-6

ORDER CODE

Nozzle pressure sensor

IN - [] - [] - [] - [] - [] - [] - [] - [] - []

Measuring range	
4000 bar	4000

IN Sensor external diameter	
60 mm	S

Cable	
Cable 3m	030

Magnetic base	
External diameter 60 mm	S
External diameter 100 mm	H

Monitor	
Monitor standard	M
Monitor with digital output	D

Heat band	
110VAC	1
230VAC	2
110VAC + 230VAC (two heat bands)	3

Example: IN - 4000 - S - 030 - S - M - 2

IN Sensor, Measuring range 4000bar, IN Sensor external diameter 60 mm, Cable 3m, Magnetic base 60mm, Monitor standard, Heat band for 230VAC

ACCESSORIES

Description	Order code	Code
Nozzle adapter type NA-IN-2	NA-IN-2	F069006
Monitor standard	IN -0000 - O - 000 - O - M - O	F063416
Monitor with digital outout	IN -0000 - O - 000 - O - D - O	F069660
Magnetic base 60mm	IN -0000 - O - 000 - S - O - O	F068444
Magnetic base 100mm	IN -0000 - O - 000 - H - O - O	F069015
Heat insulation disc	FD - IN - 1	F069007
Heat band 110VAC	IN - 0000 - O - 000 - O - O - 1	F065947
Heat band 230VAC	IN - 0000 - O - 000 - O - O - 2	F062424
Heat band 110VAC + 230VAC (two heat bands)	IN - 0000 - O - 000 - O - O - 3	F069659

GEFRAN spa reserves the right to make any kind of design or functional modification at any moment without prior notice.



Sensormate AG
Steigweg 8, - CH-8355 Aadorf, Switzerland
ph: +41(0)52-2421818 - fax: +41(0)52-3661884
Internet: <http://www.sensormate.ch>

GEFRAN

GEFRAN spa
via Sebina, 74 - 25050 PROVAGLIO D'ISEO (BS) - ITALY
ph. +39 030 9888.1 - fax. +39 030 9839063
Internet: <http://www.gefran.com>

DTS_IN Sensor_03-2017_ENG