



Main features:

- Direct measurement of surface strain
- Quick and non-destructive assembly with magnetic press-on technology
- High accuracy and linearity in tension and pressure (like bonded strain gauges)
- Ideal for use on presses, injection-moulding and die-casting machines
- Application on tie bars with a diameter of 45mm or higher and flat surfaces
- Dynamic applications
- Without amplifier (passive)

The magnetic strain gauge sensor QE1008-W measure the surface-strain directly at the mounting location in the same quality as bonded strain gages. The magnetic press-on technology, developed by Sensormate AG, presses the strain gauges under the stainless protective film so strongly against the surface to be measured that frictional contact occurs.

The mounting of the sensor is non-destructive, very fast and simple.

TECHNICAL DATA

Strain gauge type	Foil (GF = 2.0)
Bridge resistance	350Ω
Measuring range	± 800 µε
Sensitivity tolerance	± 0.2%
Transverse sensitivity	0.9 ± 0.2 %
Accuracy	<± 0,5% v. Ew.
Linearity	<± 0,5% v. Ew.
Hysteresis	<± 0,5% v. Ew.
Repeatability	< 0,2% v. Ew.
Nominal input resistance	350Ω
Supply voltage	2,5VDC (5VDC max)
Supply current	< 8mA
Operating temperature range	5...65°C
Storage temperature range	5...65°C
Overload capability	indefinite (offset occurs)
Protection class	IP54
Case material	Aluminium
Weight including cable	530g

DIMENSIONS

QE1008

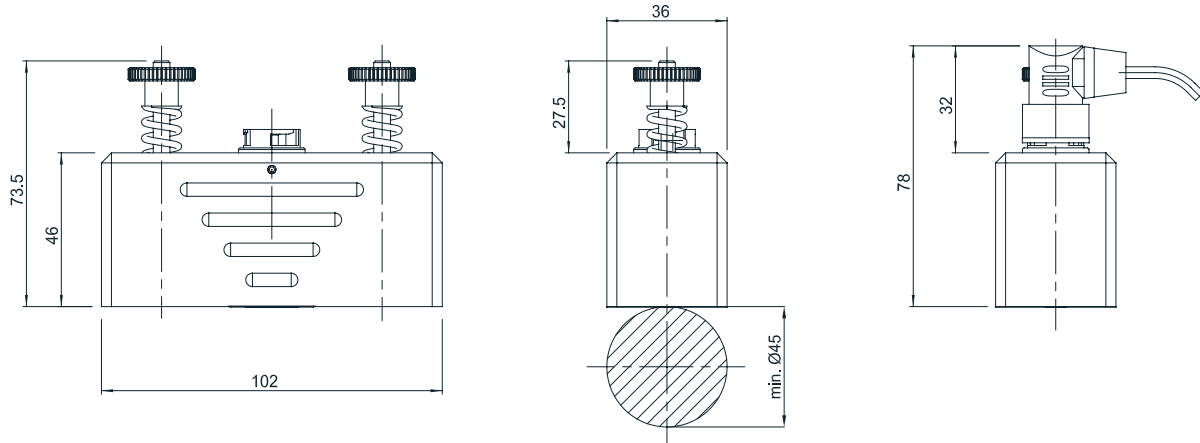

Dimensions in mm

ELECTRICAL CONNECTIONS

1/4 Bridge

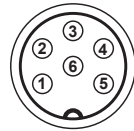
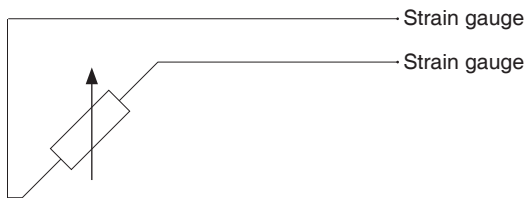

Connector PIN	Function
1	Strain gauge
2	Strain gauge
3	n.a.
4	n.a.
5	n.a.
6	n.a.

ORDER CODE

Magnet-mount strain sensor

QE1008 -

Connection	
With cable connection	C

Example: QE1008 - C

Magnet-mount strain sensor QE1008, with cable connection

ACCESSORIES

Description	Order code	Code
Y-Cable	3 m	C - 678 - 030 - 680 - Y
	5 m	C - 678 - 050 - 680 - Y
	10 m	C - 678 - 100 - 680 - Y
Repair-Kit Foil	REPAIR-KIT FOIL	F060472

GEFRAN spa behält sich das Recht vor, jederzeit und ohne Vorankündigung Änderungen an Design und Funktionen vorzunehmen.



Sensormate AG

Steigweg 8, - CH-8355 Aadorf, Switzerland
 ph: +41(0)52-2421818 - fax: +41(0)52-3661884
 Internet: <http://www.sensormate.ch>



GEFRAN spa

via Sebina, 74 - 25050 PROVAGLIO D'ISEO (BS) - ITALY
 ph. +39 030 9888.1 - fax. +39 030 9839063
 Internet: <http://www.gefran.com>

DTS_QE1008_03-2017_ENG