



Main features:

- Small press-on sensor with one-hole mounting
- Direct measurement of surface strain
- Without amplifier (passiv)
- High accuracy and linearity in tension and pressure (like bonded strain gauges)
- For dynamic applications
- Used on presses, injection moulding and die-casting machines
- Quick and easy mounting
- Protected against overload
- Optional accessories:
 - Signal amplifier VDA
 - Monitor DU-1D

The strain gauge sensor SB46 measure the surface-strain directly at the mounting location in the same quality as bonded strain gages. The press-on technology, developed by Sensormate AG, presses the strain gauges under the stainless protective film so strongly against the surface to be measured that frictional contact occurs.

The sensor can not be overloaded. The mounting is easy and very fast. The sensor do not need a recalibration when it replaced or remounted. The sensor need a cyclical reset.

TECHNICAL DATA	
Strain gauge type	Foil (GF = 2.0)
Bridge resistance	350Ω
Measuring range	±100...±1000µε
Sensitivity tolerance	± 0.2%
Accuracy	<± 0,5% FS
Linearity	<± 0,3% FS
Hysteresis	<± 0,2% FS
Repeatability	< 0,2% FS
Supply voltage	5VDC (max 8VDC)
Supply current	< 15mA
Operating temperatur range	0...55°C
Storage temperatur range	0...55°C
Overload capability	indefinite (offset occurs)
Protection class	IP54
Case material	Aluminum
Weight, including cable	80g

DIMENSIONS

SB46

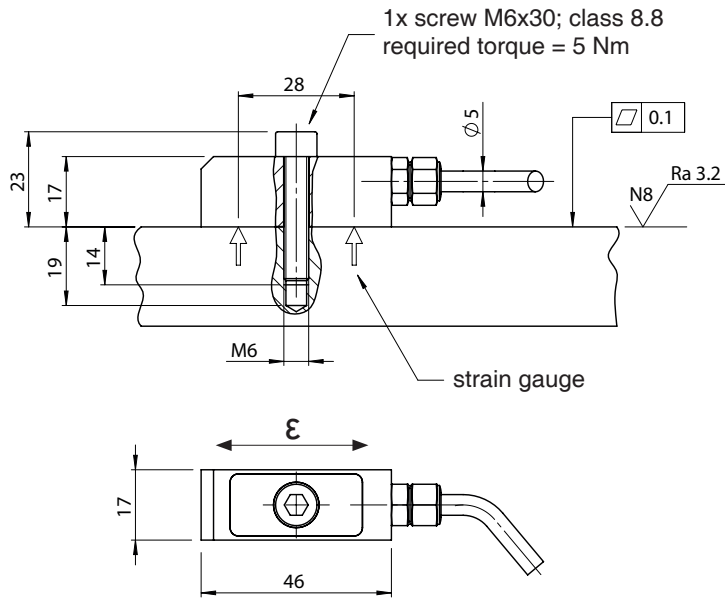

Accessories include:

1x mounting screw M6x30; class 8.8

Dimensions in mm

ELECTRICAL CONNECTIONS

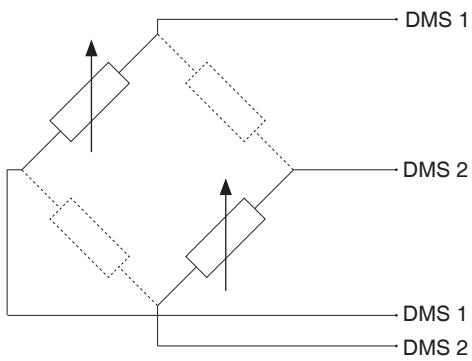

Option O: Open leads	Option C Connection pin	Function
white	1	DMS 1
brown	2	DMS 1
grey	3	n.a.
green	4	DMS 2
yellow	5	DMS 2
-	6	n.c.

Option O:

PUR screened cable (standard);
5 x 0,14mm²; Ø 5mm; bending 10x Ø

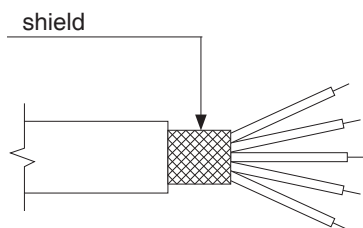

Option C:

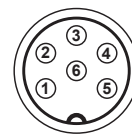

ORDER CODE

Press-on-strain sensor
without amplifier

SB46 - - - -

Housing	
Aluminum housing with one hole	A1

Bridge	
2/4 bridge	2

Cable lenght	
0.5 m	005
3 m	030
5 m	050
10 m	100

Connection	
Open leads	O
Cable with connector	C

Example: SB46 - A1 - 2 - 030 - O

Press-on-strain sensor SB46, aluminum housing, 2/4 bridge, cable lenght = 3m, open leads

ACCESSORIES

Description

Variable digital amplifier VDA (see amplifier's datasheet for ordering information)



GEFRAN

Sensormate AG

Steigweg 8, - CH-8355 Aadorf, Switzerland
ph: +41(0)52-2421818 - fax: +41(0)52-3661884
Internet: <http://www.sensormate.ch>

GEFRAN spa

via Sebina, 74 - 25050 PROVAGLIO D'ISEO (BS) - ITALY
ph. +39 030 9888.1 - fax. +39 030 9839063
Internet: <http://www.gefran.com>