



Main features:

- Available for all Sensormate sensors (2/4 bridges)
- Direct display of the measured values in $\mu\epsilon$, kN or t
- High accuracy and stable reset
- Automatic reset, external reset and alarm output
- Ideal for control cabinet installation (96x96mm, DIN 43700)
- Battery operation possible (optional) / not rechargeable

The DU-1D Monitor is an industrial signal amplifier and monitor for strain gauges and strain sensors. It has integrated functions for external and internal (automatic) reset. Force measurement on tie bars displays in kN or tons and diameter input. Strain measurement displays in $\mu\epsilon$ (micro strain). Direct switch units and change parameters. The handling is very user-friendly

Application: The device DU-1D is used in conjunction with tie bar strain-sensors of the Sensormate AG for the control of the clamping force on presses, injection-moulding and die-casting machines. The ALARM relay allows to stop the machine in case of overload. Ideal to retrofit on existing machines.

TECHNICAL DATA

Input Bridge resistance	350...1000 Ω
Signal input range (FS)	0.1...1mV/V
Resolution ADC	16-Bit
Sampling rate	500Hz
Output rate	40Hz
Display refresh	100Hz
Output signal	Display (\pm 9999 digit, 1 channel)
Noise	\leq 1 digit
Accuracy	$< \pm$ 0.05% FS
Accuracy of zero point	\leq 1 digit
Linearity	$< \pm$ 0.5% FS
Alarm reaction time	$>$ 25ms
Reset time	$>$ 200ms
Reset voltage	15...28VDC
Supply voltage	12VDC
Supply current	$<$ 100mA
Inverse polarity protection	Yes
Accidental short-circuit protection	No
Operating temperatur range	0...+65°C
Storage temperatur range	-40...+80°C
Temperature coefficient at 10°C	$<$ 0.1 (0.05 typical)
Protection class	IP50
EMC	2014/30/EU
Case material	Plastic
Weight	210g

DIMENSIONS

Option: Installation-Housing

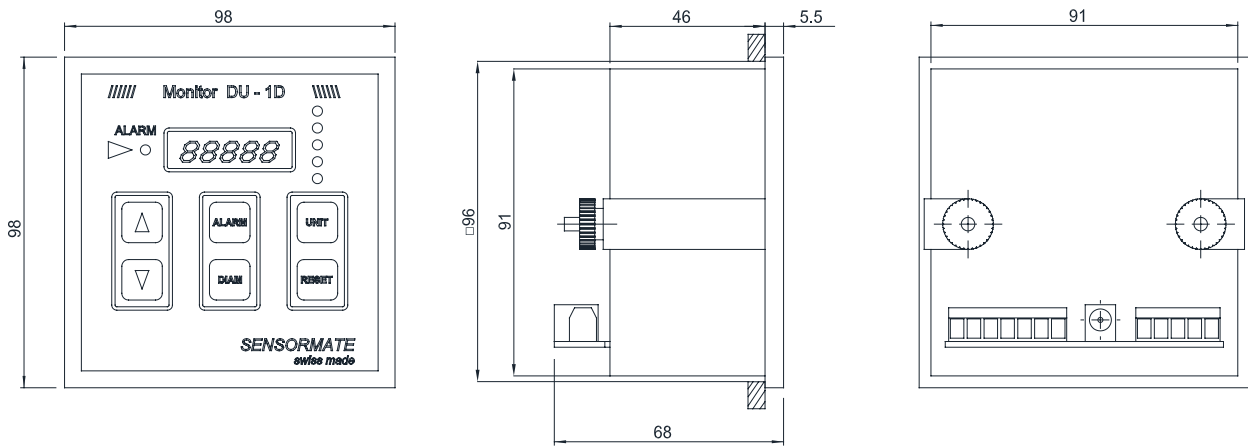

Option: Box- Housing

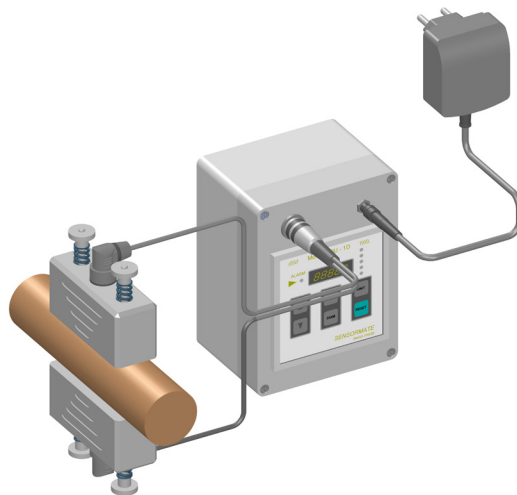
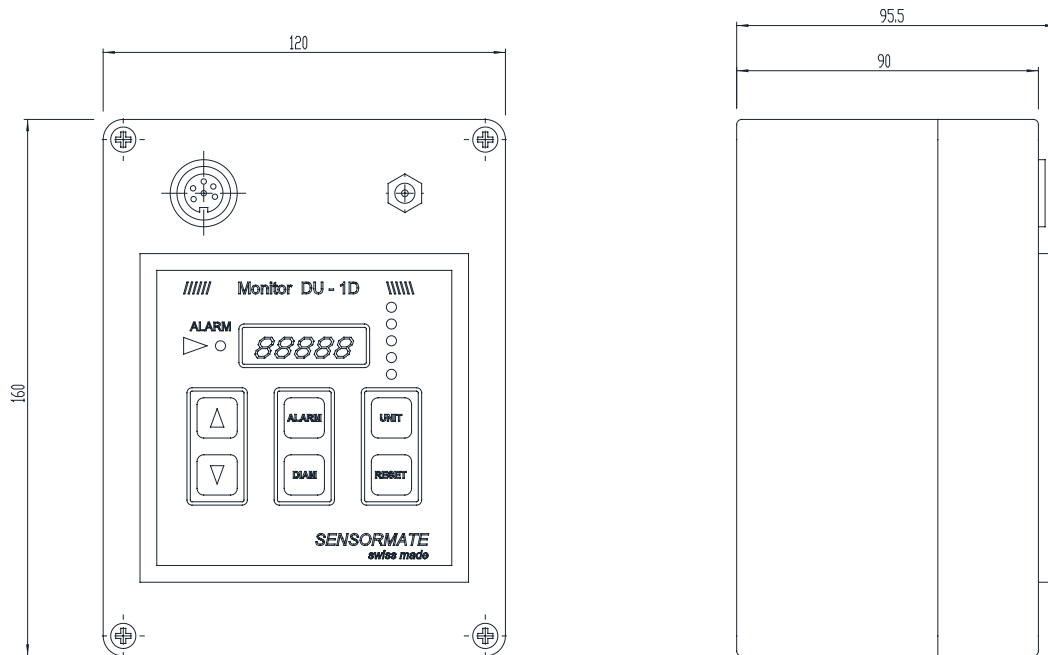

FACEPLATE DESCRIPTION

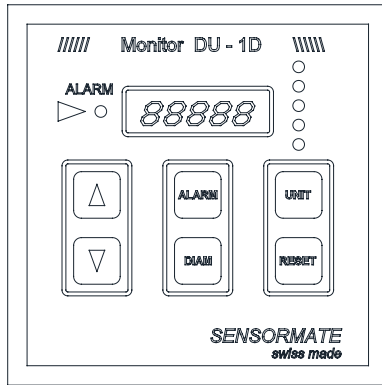

	Decrease chosen value
	Increase chosen value
ALARM	Set alarm threshold
DIAM	Set tie-bar diameter
UNIT	Select unit ($\mu\epsilon$, kN or tons)
RESET	Set measurement to zero
LED's	Indicate actual unit and/or mode
ALARM LED	LED on = alarm out active

ELECTRICAL CONNECTIONS

2/4 bridge sensor

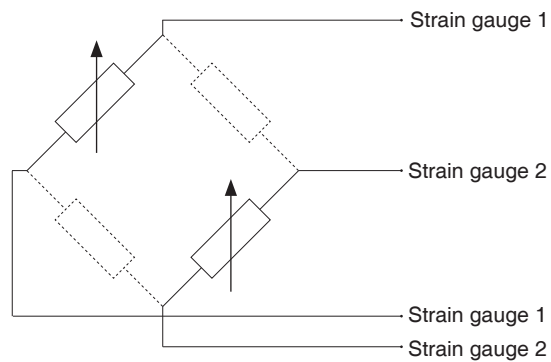

Option: Installation-Housing

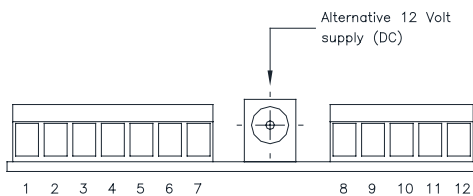

Option: Box-Housing



Option: Installation Housing	Function	Option: Box Housing
Connection pin		Connection M16 x 6-pin
1	Power supply 12VDC	Alternative Connection
2	GND	Alternative Connection
3	Reset +	-
4	Reset -	-
5	Alarm switch	-
6	Alarm switch open	-
7	Alarm switch closed	-
8	Strain gauge 1	1
9	Strain gauge 1	2
10	Shield	-
11	Strain gauge 2	4
12	Strain gauge 2	5
-	-	-

ORDER CODE

1- CHANNEL DIGITAL MONITOR

DU1D - - -

Calibration for	
3 m cable length	03
5 m cable length	05
10 m cable length	10





Box housing	
With Box housing	B
None	N

Features	
With battery case	BAT
US-tons instead of tons	UST
With battery case + US-tons	BUS
No features	000

Example: DU1D - 05 - N - 000

1- channel digital monitor, calibrated for 5m cable length, no Box housing, no features

ACCESSORIES

Description	Order code	Code
Connector-cable (0.3m) for sensors (open leads)	C - 680 - 003 - O - S	F062410
Power supply 12VDC for DU-1D (incl. 4x plug adapter)    		F069683

GEFRAN spa reserves the right to make any kind of design or functional modification at any moment without prior notice.



Sensormate AG
Steigweg 8, - CH-8355 Aadorf, Switzerland
ph: +41(0)52-2421818 - fax: +41(0)52-3661884
Internet: <http://www.sensormate.ch>

GEFRAN

GEFRAN spa
via Sebina, 74 - 25050 PROVAGLIO D'ISEO (BS) - ITALY
ph. +39 030 9888.1 - fax. +39 030 9839063
Internet: <http://www.gefran.com>

DTS_DU1D_06-2017_ENG