

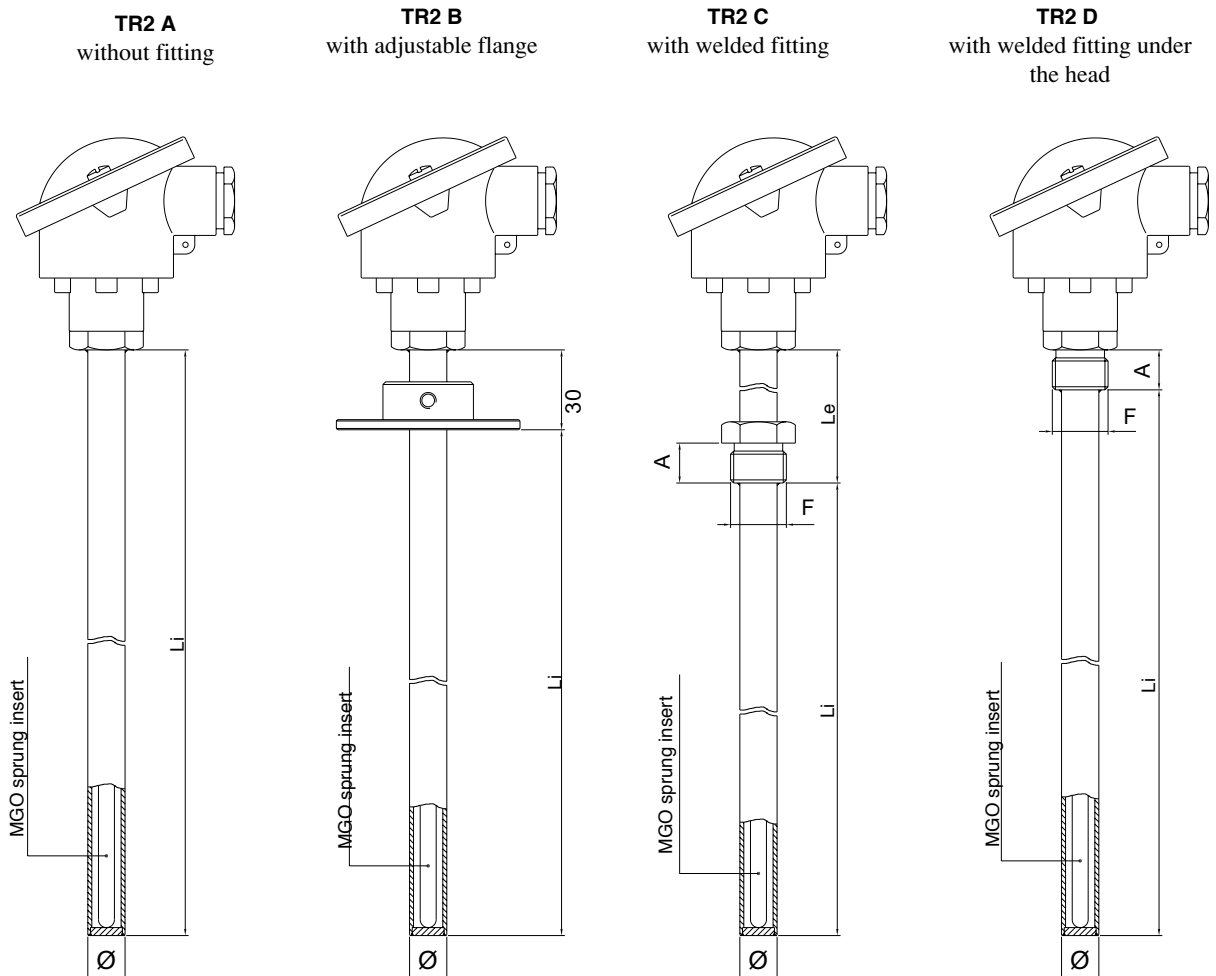

Main features

- Temperature Limits: - 80 ... + 600° C
- Tolerance: UNI 7937, IEC 751 standards:
 $\pm 0.15^{\circ} \text{C}$ a 0°C for class A (1/2 DIN)
 $\pm 0.30^{\circ} \text{C}$ a 0°C for class B (1 DIN)
 $\pm 0.10^{\circ} \text{C}$ a 0°C for class 1/3 DIN
- Insulation: > 100 MOhm for voltage values from 10 to 100 Vcc.
- PT100 wire-wound resistance thermometer
- Mineral insulated interchangeable insert
- Application versatility

MODELS



ORDER CODE

CODE

T R 2 [] [] [] [] [] [] [] [] [] [] 0

[] [] [] 0 X [] [] [] [] [] [] [] [] [] [] X [] []

Model	
Without fitting	A
With adjustable flange	B
With welded fitting	C
With welded fitting under the head	D

Element + Nr. of Wires	
Single 2 wires	1
Single 3 wires	2
Double 2 wires	3
Double 3 wires	4
Single 4 wires	5

Precision Class	
PT100 class A (1/2 DIN)	A
PT100 class B (1 DIN)	B
PT100 class (1/3 DIN)	C

Connection Head	
DIN B	C
DIN BUS	E
EEX d IIC 2GD	F
CEAA	H
DIN BUZ - H	I

Sheath Material	
AISI 304	A
AISI 310	B
AISI 316	C
INCONEL 600	F

Sheath Diameter (mm)	
10	K
12	L
14	M
16	O
17.2 (3/8")	P
21.3 (1/2")	Q
26.7 (3/4")	T

Connection Thread *		
3/8" GAS	"A"= 15mm	C
1/2" GAS	"A"= 15mm	D
3/4" GAS	"A"= 18mm	E
1" GAS	"A"= 18mm	F
3/8" NPT		I
1/2" NPT		J
3/4" NPT		K
1" NPT		L

* To be shown for C model only

Connection/Flange Material	
300 Series Stainless Steel	2 *
Aluminium	4 **
Carbon steel	5 **

(*) For fitting only

(**) For flanges only

Certificates	
A	Conformity Report
R	Calibration Report
T	SIT Certificate

LENGTHS AND ACCESSORIES

Li = Immersion Length (mm)
Standard length from 100 to 2000 mm with 50 mm step

Le = Extension Length (mm) *
Standard length from 35 to 200 mm with 10 mm step

(*) Available for TR2C only

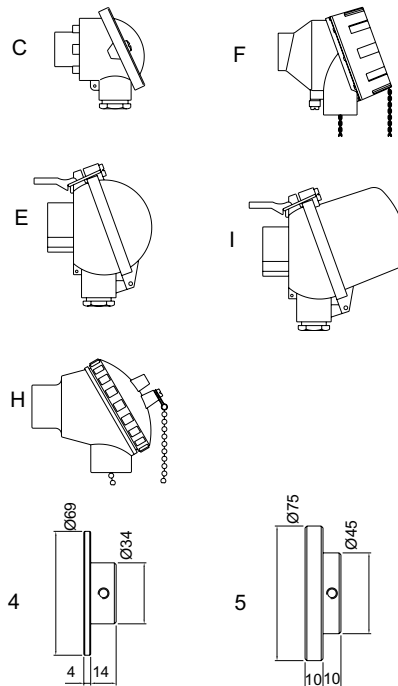

MOUNT (F)	Mod. C - D A (mm)	Availability of Mounts /Sheathing Diameter							
		Mount (F)	Ø10	Ø12	Ø14	Ø16	Ø17.2	Ø21.3	Ø26.7
G 3/8	15	G 3/8	x	x	-	-	-	-	-
G 1/2	15	G 1/2	x	x	x	x	-	-	-
G 3/4	18	G 3/4	x	x	x	x	x	-	-
G 1	20	G 1	x	x	x	x	x	x	x
3/8 NPT	16	3/8 NPT	x	x	-	-	-	-	-
1/2 NPT	20	1/2 NPT	x	x	x	x	-	-	-
3/4 NPT	20	3/4 NPT	x	x	x	x	x	-	-
1 NPT	25	1 NPT	x	x	x	x	x	x	x

GEFRAN spa reserves the right to make any kind of design or functional modification at any moment without prior notice

GEFRAN spa
 via Sebina, 74
 25050 PROVAGLIO D'ISEO (BS) - ITALIA
 ph. 0309888.1 - fax. 0309839063
 Internet: <http://www.gefran.com>
www.gefranonline.com

GEFRAN

DTS_TR2_07-2012_ENG