



Dimensions 96 × 96 × 80 mm (1/4 DIN)

Main features

- Operator interface with large LCD display and three configurable bar graph
- Scrolling diagnostics messages, configurable, in the selected language
- Easy, guided configuration, copy/ paste parameters even with power off
- Preventive maintenance with energy counters (kWh) and load switching
- 32 function block applications
- 8 math application blocks
- Timer, setpoint and algorithm programmer for controlling motorized valves
- Advanced tuning of control parameters
- Different password levels
- 2 universal inputs configurable for thermocouples, resistance thermometers, linear inputs
- 2 PID control loop
- 2 setpoint programmers (128 steps in 16 programs)
- Relay, logic, isolated analog outputs
- Up to two CT inputs for interrupted load diagnostics
- RS485 serial communication in Modbus RTU
- Removable faceplate for immediate replacement
- Sampling time 60 ms

PROFILE

Operator interface

Large LCD display with customization of plastic front panel color and logo.

Graphic display of power, output current or valve position. Scrolling alphanumeric display of 25 messages (32 letters each), completely configurable and savable, in three languages.

Thanks to language selection and clear scrolling messages for diagnostics, alarms, and process state, the controller speaks the user's language.

Control

Double loop, two configurable universal inputs for thermocouples, resistance thermometers, linear inputs.

Second input can be configured as remote setpoint of single loop.

Easy Configuration

Guided configuration for manual-free programming, with a few essential parameters and on-line help messages.

Ability to clone configuration among controllers, even with power off and in the field, thanks to a mini portable configurator with Zapper battery.

Extended configuration, creation of work recipes, and firmware updates via PC and GF_eXpress software, even without powering the controllers.

Thanks to the Smart Configurator function, you obtain the required parameter recipe by answering a few simple questions. Local configuration and operation with only four keys assigned to LEDs that serve as feedback for the pressed key and as guide to specify appropriate steps.

The initial parameters can always be reset, both from the keypad and from the GF_eXpress Software tool.

Diagnostics, Preventive Maintenance, and Energy Monitor

Complete diagnostics for broken or incorrectly connected probe, total or partial load break, out of range variables, and control loop faults.

Thanks to the switching count and to the settable alarm thresholds, you can program preventive maintenance to replace worn actuators.

An internal energy counter with alarm for abnormal variations totalizes energy consumptions and costs for constant control.

Function block applications

32 AND, OR, Timer Function Blocks let you create customizable logic sequences for complete and flexible machine control.

The controller's hardware resources are exploited completely, without any need for external devices such as timers and small PLCs.

There are 8 math Function Blocks to process

analog variables and add/subtract/multiply/divide, calculate average, root, logarithms and control functions in cascade, and ratio check.

Options are available with 8 digital inputs/ outputs and 8 additional relay outputs to be managed via Function Blocks with state signals via dedicated LEDs on the LCD display.

Tuning

Advanced tuning algorithms ensure stable and accurate control even with critical or very rapid thermal systems, engaging automatically when necessary.

Timer

Three types of timers let you set delay times before activating the control, hold times on the setpoint value, and timed changes of programmed setpoints.

Setpoint Programmer

Models with 128 steps (each step consisting of a ramp and a hold), groupable in a maximum of 16 programs, are available for applications with setpoint profiles.

Enable inputs, event outputs, and messages to display can be assigned to each step. Double Programmer with synchronous and asynchronous base times for activating two setpoint profiles (even separate) assigned to the two loops.

On-board configuration and graphic configuration with GF_eXpress.

Valve Positioner

Models to control motorized valves, with or without feedback. The position is calculated for floating valves. For valves with potentiometer via auxiliary input you can control and display the position.

Connectivity

Modbus RTU on RS485 2 wire connection.

General characteristics

The controller is completely software configurable without accessing the internal electronics.

The universal main input accepts thermocouple sensors, resistance thermometers, and linears.

The controller can be replaced at any time simply by removing the faceplate, without any additional procedures.

DISPLAY AND KEYS

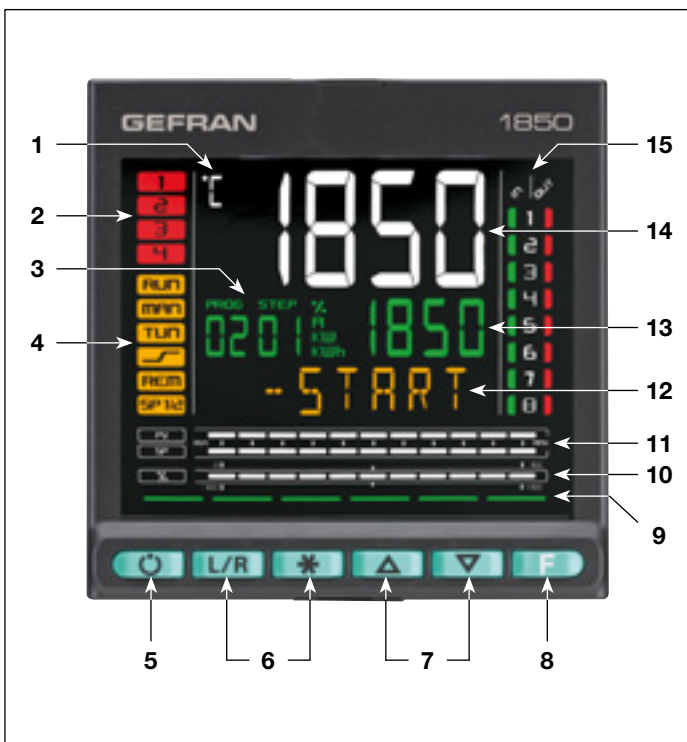

- Key function configurable with parameters but2 and but3. The keys are active only when the display shows the process variable. (HOME).
- Up/down keys: raise/lower the value of the parameter displayed on the SV or PV display.
- F key: lets you navigate among controller menus and parameters. Confirms the parameter value and selects the next parameter.
- Key pressed signals.
- Displays percentage of power or current, configurable with parameter bArG.
- Display of percentage of process variable and of setpoint.
- F display: parameters, diagnostics and alarm messages. Configurable with parameter dS.F (default = setpoint).
- SV display: parameter values. Configurable with parameter dS.SP (default = setpoint).
- PV display: process variable.
- Display of inputs/outputs state (only with 8 INS/OUTS and/or 8 relays option).

- Unit of measurement or number of program running or number of loop displayed.
- State of outputs OUT1, OU2, OUT3, OUT4.
- Displays program number, step number, unit of measurement (% , A, kW, kWh).
- Controller function states:
 - RUN = functioning (flashing = normal functioning, steady on = program running);
 - _/- = setpoint ramp active;
 - TUN = PID parameters tuning active;
 - MAN = manual/automatic (off = automatic control, on = manual control);
 - REM = remote setpoint enabled;
 - SP1/2 = setpoint active (off = setpoint 1, on = setpoint 2).
- Work mode key (manual/automatic) in standard mode. A function can be assigned via parameter but1. The key is active only when the display shows the process variable. (HOME).

DIMENSIONS AND DRILLING TEMPLATE

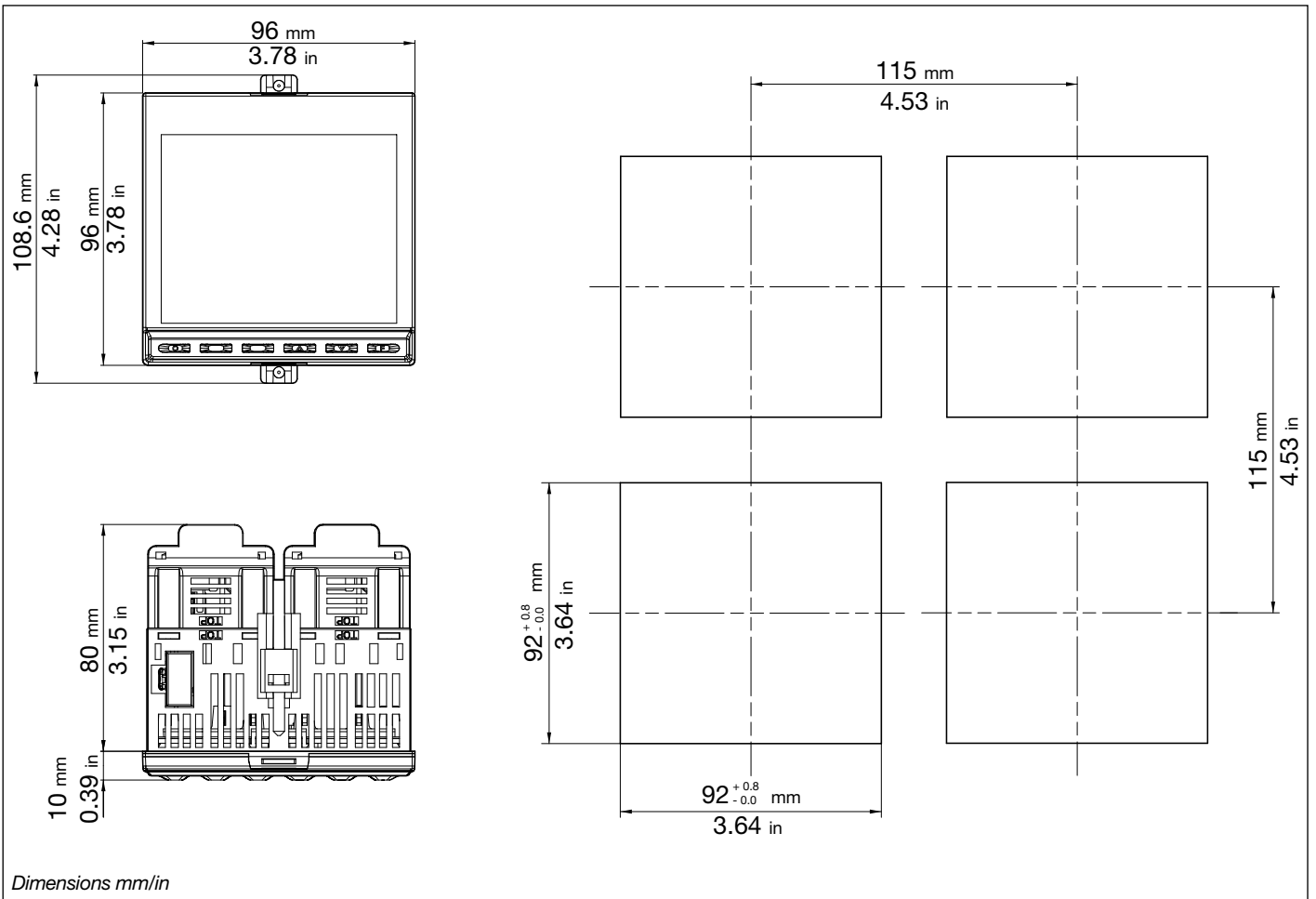

TECHNICAL DATA
OPERATOR INTERFACE

| | | |
|----------------|---|--|
| DISPLAY | Type | LCD black background |
| | Screen area (L x H) | 83 x 68 mm |
| | Lighting | Backlit with LEDs, life > 40,000 hours @ 25°C (with brightness level backl = 0.8) |
| | PV display | Number of digits: 4 to 7 segments, with decimal point Digit height: 23 mm Color: white |
| | SV display | Number of digits: 4 to 7 segments, with decimal point Digit height: 11 mm Color: green |
| | F display | Number of digits: 7 to 14 segments, with decimal point Digit height: 9 mm Color: amber |
| | Unit of measurement | Selectable, °C, °F or custom ¹ Color: same as PV display |
| | Controller state signals | Number: 6 (RUN, MAN, _/-, REM, SP1/2) Color: amber |
| | Output state signals | Number: 4 (1, 2, 3, 4) Color: red |
| | Bargraph indicator, configurable | Type: graphic bargraph, 11 segments Power indication: 0...100% or -100...100% Current indication: 0...100% f.s. Valve position indication: 0...100% |
| | Bargraph indicator | Type: double bar, 11 segments Indication of process variable and setpoint: 0...100% f.s. |
| | Inputs/outputs state signal (only with option) | Number: 8 inputs, 8 outputs Color: green for inputs, red for outputs Control via FB outputs |
| KEYPAD | | Keys number: 6, silicone (Man/Auto, L/R, *, INC, DEC, F) Type: mechanical |

INPUTS

| | | |
|-------------------|--|---|
| MAIN INPUT | Sensor type | TC, RTD (PT100, JPT100), IR ES1B, DC linear sensor |
| | Accuracy | TC input Calibration accuracy: < ± (0,25% of reading in °C +0,1°C) Linearization accuracy: 0,1% of reading Cold junction accuracy: < ± 1°C a 25°C ambient temperature Cold junction compensation: > 30:1 rejection to the change of the ambient temperature RTD input Calibration accuracy: < ± (0,15% of reading in °C +0,4°C) Temperature drift: < ± (0,005% of reading in °C +0,015°C)/°C from 25°C ambient temperature Linearization accuracy: 0,1% of reading Linear input: Calibration accuracy: < 0,1% F.S. Temperature drift: < ± 0,005% F.S. /°C from 25°C ambient temperature |
| | Sampling time | 60 ms / 120 ms, selectable |
| | Digital filter | 0,0...20,0 s |
| | Temperature unit of measurement | Degrees C / F, selectable from keypad |
| | Signal interval | Type: linear Scale: -1999...9999, settable decimal point |
| | TC (thermocouple) input | Thermocouple: J, K, R, S, T, C, D Linearization: ITS90 or custom |
| | RTD (resistance thermometer) input | Resistance thermometer: PT100, JPT100 Input impedance (Ri): ≥ 30 kΩ Linearization: DIN 43760 or custom Max. line resistance: 20 Ω |
| DC linear input | 0...60 mV input impedance (Ri): > 70 kΩ 0...1 V input impedance (Ri): > 15 kΩ 0...5 V / 0...10 V input impedance (Ri): > 30 kΩ 0/4...20 mA input impedance (Ri): 50 Ω Linearization: linear or custom | |

| | | |
|---------------------------|------------------------------------|---|
| AUXILIARY INPUT | Sensor type | TC, RTD (PT100, JPT100), IR ES1B, DC linear sensor |
| | Accuracy | TC input Calibration accuracy: $\pm 0,25\%$ of reading in $^{\circ}\text{C} +0,1^{\circ}\text{C}</math>Linearization accuracy: 0,1% of readingCold junction accuracy: $\pm 1^{\circ}\text{C}$ a 25^{\circ}\text{C}</math> ambient temperatureCold junction compensation: > 30:1 rejection to the change of the ambient temperatureRTD inputCalibration accuracy: $\pm 0,15\%$ of reading in ^{\circ}\text{C} +0,4^{\circ}\text{C}</math>Temperature drift: $\pm 0,005\%$ of reading in ^{\circ}\text{C} +0,015^{\circ}\text{C}</math> /^{\circ}\text{C}</math> from 25^{\circ}\text{C}</math> ambient temperatureLinearization accuracy: 0,1% of readingLinear input:Calibration accuracy: <math>< 0,1\%</math> F.S.Temperature drift: $\pm 0,005\%$ F.S. /^{\circ}\text{C}</math> from 25^{\circ}\text{C}</math> ambient temperature$ |
| | Sampling time | 60 ms / 120 ms, selectable |
| | Digital filter | 0,0...20,0 s |
| | Temperature unit of measurement | Degrees C / F, selectable from keypad |
| | Signal interval | Type: linear Scale: -1999...9999, settable decimal point |
| | TC (thermocouple) input | Thermocouple: J, K, R, S, T, C, D Linearization: ITS90 or custom |
| | RTD (resistance thermometer) input | Resistance thermometer: PT100, JPT100 Input impedance (Ri): $\geq 10\text{ M}\Omega</math>Linearization: DIN 43760 or customMax. line resistance: 20\ \Omega</math>$ |
| | DC linear input | 0...60 mV input impedance (Ri): $> 10\text{ M}\Omega</math>0...1 V input impedance (Ri): > 300\text{ k}\Omega</math>0...5 V / 0...10 V input impedance (Ri): > 300\text{ k}\Omega</math>0/4...20 mA input impedance (Ri): 50\ \Omega</math>Linearization: linear or custom$ |
| | Isolation | Functional isolation 250 V |
| CT (ammeter) input | Type | Isolated via external transformer |
| | | Number: 2 max Max. capacity: x / 50 mA AC Line frequency: 50/60 Hz Input impedance (Ri): $10\ \Omega</math>$ |
| | Accuracy | $\pm 2\%$ f.s. ± 1 digit @ $25^{\circ}\text{C}</math>$ |
| DIGITAL INPUTS | Numero | 5 max |
| | Type | voltage-free contact, or NPN 24 V - 4,5 mA, o PNP 12/24 V - max 3,6 mA <i>For detail see electrical connections</i> |
| | Isolation | 250 V |

| OUTPUTS | | |
|--------------------------|-------------------------------------|---|
| | Relay (R) | Number: 4 max Type of relay contact: NO Max. current: 5A (2A at ambient temperature up to 45 ° C for certification UL), 250VAC / 30 VDC, $\cos\phi = 1$ Minimum load: 5 V, 10 mA Life cycle: > 100.000 operations Double isolation |
| | Logic (D) | Number: 2 max Type: for solid-state relays Voltage: 24 V $\pm 10\%$ (min 10 V @20 mA) Isolated from main input |
| | Isolated logic (M) | Number: 2 max Type: MOS optoisolated for PLC inputs and AC/DC load Voltage: 30 V AC/DC max Current: 100 mA max Resistance ON: 0,8 Ω max Isolation: 1500 V |
| | Triac (long life relè) (T) | Number: 1 max Load: resistive Voltage: 75...240 VAC Current max: 1 A Isolation 3 kV snubber circuit integrated zero crossing switching |
| | Continuous (C) | Number: 1 max Current: 4...20mA $R_{out} < 500 \Omega$ Resolution: 12 bit Isolated from main input |
| | Analog retransmission (A1) (A2) | Number: 2 max 0...10 V, max 20 mA, $R_{out} > 500 \Omega$ 0...20 mA, 4...20 mA, $R_{out} < 500 \Omega$ Resolution: 12 bit Isolated from main input |
| ALARMS | Number of alarm functions | 4 max, assignable to an output |
| | Possible configurations | Maximum, minimum, symmetric, absolute/relative, exclusion at firing, memory, reset from keypad and/or contact, LBA, HB, HBB Hold Back Band if enabled with Programmer function, alarm after power variation at full power |
| POWER SUPPLY | For sensor VT, VT2 | Voltage: 24 VDC $\pm 10\%$ Current max: 30 mA VT option of Out3 |
| | For potentiometer VP | Voltage: 1 VDC $\pm 1\%$ Current max: 30 mA |
| INPUTS / OUTPUTS | | |
| | Digital Inputs/Outputs | Number: 8, in two groups (5 + 3 with separate power supply) Input: PNP 24 VDC, 5 mA Output: PNP with 24 VDC external power supply, $\pm 25\%$, max 100 mA, short circuit protection with PTC Isolation: 250 V |
| | Relay | Number: 8, in two groups (5 + 3 relays with common contact) Type of relay contact: NO Max. current: 5A (at ambient temperature up to 45 ° C for certification UL), 250VAC / 30 VDC, $\cos\phi = 1$ Max. current for each common: 5 A Life cycle: > 100.000 operations Double isolation |
| CONTROL FUNCTIONS | | |
| CONTROL | Type | Single/Double loop |
| | Control | PID, ON/OFF, single action heat or cool, double action heat/cool |
| | Control output | Continuous or ON/OFF Cycle time: constant or optimized (BF) |
| | Control output for motorized valves | OPEN/CLOSE for floating motorized valve or with feedback with position control by potentiometer on Relay, Solid-state, Triac outputs. |

| | | |
|--|-------------------------------------|---|
| SETPOINT PROGRAMMER (Double programmer if double loop) | Number of programs | Max 16 (if double loop 8 + 8) Start / Stop / Reset / Skip via digital inputs and/or outputs from logic operations Output state: Run /Hold / Ready / End |
| | Number of steps | Max 128, each with own setpoint, ramp time and hold time Times settable in HH:MM or MM:SS Max 4 consents, configurable for ramp and for hold Max 4 events, configurable in ramp and in hold |
| MULTIPLE SETPOINTS | Number of setpoints | Max 4, selectable from digital input Each setpoint change is subject to set ramp, different for up and down ramp |
| LOGIC ¹ OPERATIONS | Digital function blocks | Max 32, with 4 input variables per block. The result can act on the state of the controller, of the programmer on alarms and outputs. Each function has an AND, OR with TIMER block |
| OPERATIONS MATHEMATICAL ¹ | Analog function blocks | Max 8, with 2 input variables per block, with operators such as +, -, ×, :, average, square root, ... The result may act on analog variables in input to PID loops (controlled variable, setpoint) or analog outputs . |
| TIMER FUNCTION | Modes | START / STOP (2 timer if double loop) STABILIZATION (timer is on when PV enters a band set around setpoint; at end of count you can activate an output, shut down SW or change SP1/SP2) FIRING (timed activation of control after power on) |
| ENERGY COUNTER | | Calculation done on nominal line voltage and nominal load power or on rms current measured on load via CT |
| DIAGNOSTIC | | Short circuit or open circuit (LBA alarm) Interrupted or partially interrupted load (HB alarm) Short circuit of control output (SSR alarm) |
| RETENTIVE MEMORY | Type | FRAM |
| | Writes | Number max: > 10 ¹⁰ cycles Retention: > 10 years |
| GENERAL DATA | | |
| POWER SUPPLY | Operating voltage | 100...240 VAC/VDC ±10%, 50/60 Hz (20...27 VAC/VDC ±10%, 50/60 Hz) |
| | Power dissipation | 12 W max |
| | Protections | Overvoltage 300 V / 35 V |
| | Connection | Screw terminals and crimp connector, max. wire section 1 mm ² |
| CONNECTIONS | Serial configuration port | Connector: microUSB |
| | RS485 (option) | Baudrate: 1200, 2400, 4800, 9600, 19.200, 38.400, 57.600, 115.200 bit/s Protocol: Modbus RTU Insulation compared to main entrance Screw terminals and crimp connector, max. wire section 2.5 mm ² |
| | Inputs and outputs | Screw terminals and crimp connector, max. wire section 2.5 mm ² |
| AMBIENT CONDITIONS | Use | Internal |
| | Altitude | 2000 m max |
| | Operating temperature | -10 ... +55 °C (as per IEC 68-2-14) |
| | Storage temperature | -20 ... +70 °C (as per IEC 68-2-14) |
| | Relative humidity | 20...85% RH non condensante (as per IEC 68-2-3) |
| PROTECTION LEVEL | | IP 65 on front panel (as per IEC 68-2-3) |
| ASSEMBLY | Positioning | On panel, removable faceplate |
| | Installation regulations | Installation category: II Pollution degree: 2 Isolation: double |
| DIMENSIONS | | 96 X 96 mm (1/4 DIN) Depth: 80 mm |
| WEIGHT | | 0,24 kg |
| CE STANDARDS | EMC (electromagnetic compatibility) | Conforms to Directive 2014/30/EU norme EN 61326-1 Emissions in industrial environment classe A |
| | LVD safety | Conforms to Directive 2014/35/EU norme EN 61010-1 |

1) Programming is done with the GF_eXpress configuration program.

ACCESSORIES

| Code | Description |
|----------------|---|
| F060800 | Cable for programming with PC, USB-TTL 3 V with USB – microUSB connectors, length 1.8 m |
| F043958 | “GF_eXpress” software CD |
| F060909 | Configuration kit for new instruments |
| 51970 | Rubber gasket 96×96 front box |
| 51069 | Rubber gasket 99×96 box-panel |
| 49030 | Fastening box to panel |
| 51328 | Protection of contacts at box bottom |
| 51738 | 36 contacts at box bottom |
| 330200 | Current transformer (CT) 50/0.05 A |
| 330201 | Current transformer (CT) 25/0.05 A |

CONNECTION DIAGRAM

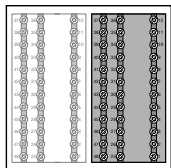

OUT 4

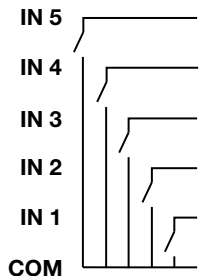
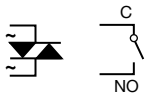

**Option
Modbus RTU (M) = M0
Communication**

B (Data +)
A (Data -)

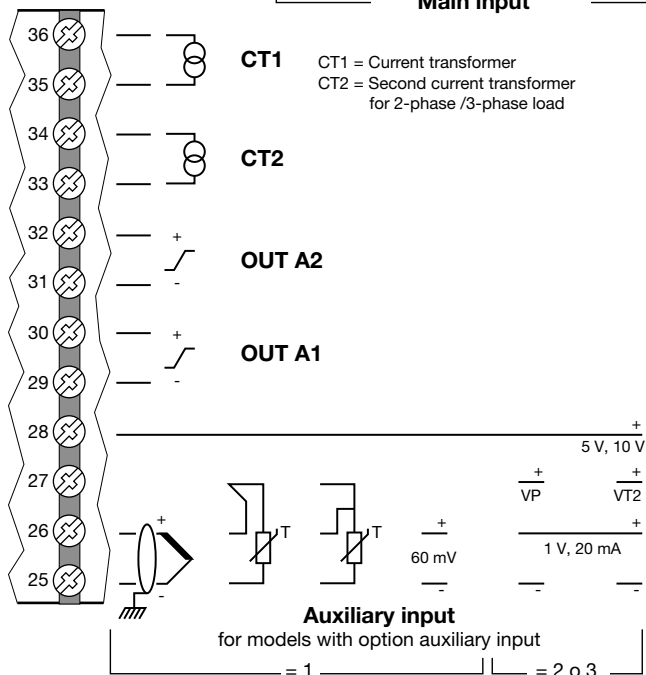
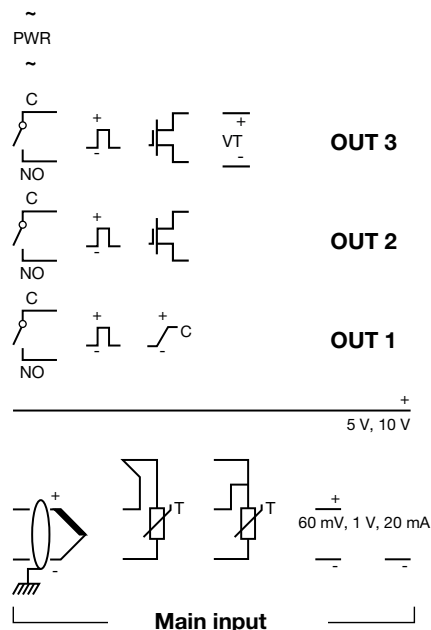
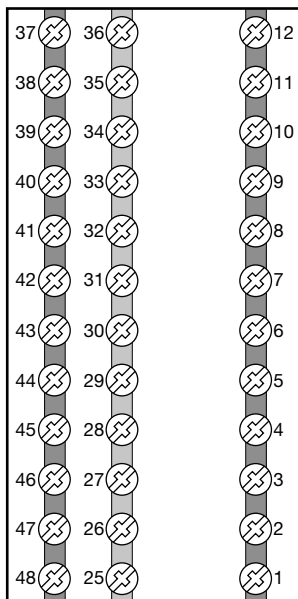

LEGEND

- ~ PWR Power supply
- + Linear input in voltage / current
- Input for current transformer
- + AUX Auxiliary input

- Isolated digital inputs
- Thermocouple input
- Input PT100 JPT100 2 / 3 wires

- Relay output
- Long-life solid state relay output
- Logic output
- Isolated logic output
- Isolated analog output

- B (Data +) RS485 serial line
- A (Data -)
- + VP Supply transmitter
- + VT Supply potentiometer



ATTENTION: For correct installation, read the warnings in the instruction manual.

CONNECTION DIAGRAM

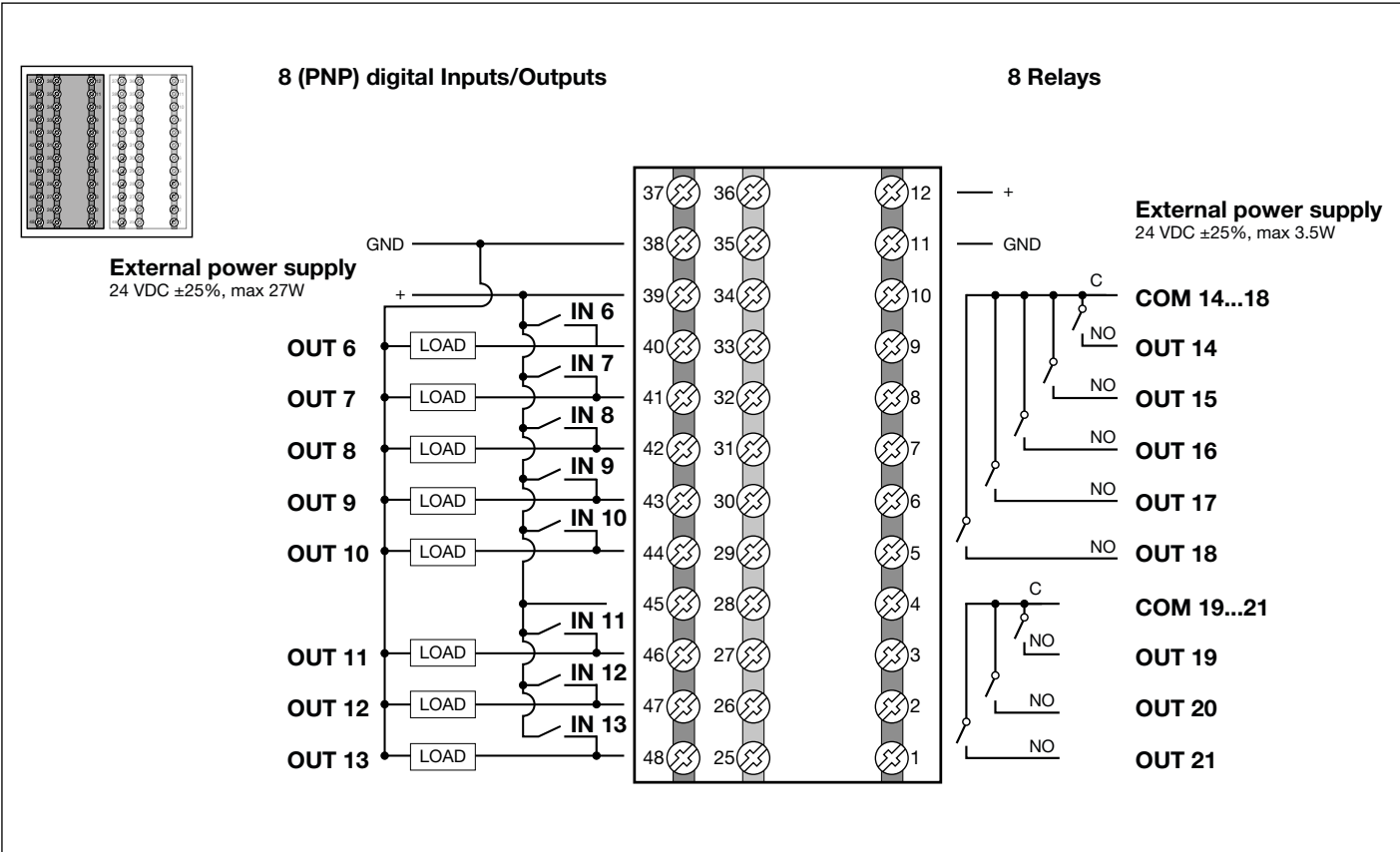

ATTENTION: For correct installation, read the warnings in the instruction manual.

ORDER METHODS

Ordering code: 1850 X-X-XXX-0-X-XX-X-XX-X-XX

| Model (A) | |
|-------------------------------|----|
| Controller | |
| Programmer | P |
| Valve ⁵ | V |
| Programmer+valve ⁵ | PV |

| Output 1 (B) | |
|--------------|---|
| Relay | R |
| Logic | D |
| Analog | C |

| Output 2 (C) - Output 3 (D) | |
|---------------------------------|-----|
| Relay - Relay | R R |
| Logic - Logic | D D |
| Isolated logic - Isolated logic | MM |
| Relay - VT 24 V | R V |
| Logic - VT 24 V | D V |
| Isolated logic - VT 24 V | M V |

| Output 4 (E) | |
|-----------------|---|
| Absent | 0 |
| Relay | R |
| Long Life relay | T |

| Retransmission (G) | |
|--------------------|---|
| Absent | 0 |
| Analogue A1 | 1 |
| Analogue A1 + A2 | 2 |

| Fonction (P) | |
|--------------|-----------------------------------|
| 00 | Absent |
| FB | Logical + mathematical operations |

| Supply (O) | |
|------------|---------------------|
| 0 | 20...27 VAC / VDC |
| 1 | 100...240 VAC / VDC |

| I/O optional (N) ⁴ | |
|-------------------------------|--------------------|
| 00 | Absent |
| 10 | 8 IN/OUT |
| 01 | 8 relay |
| 11 | 8 IN/OUT + 8 relay |

| Communication (M) | |
|-------------------|------------------|
| 00 | Absent |
| M0 | RS485 Modbus RTU |

| Digital inputs (L) | |
|--------------------|---------------------|
| 0 | Absent ³ |
| 5 | 5 DI |

| Auxiliary input (I) | |
|---------------------|-----------------------------------|
| 0 | Absent |
| 1 | Input Aux ² |
| 2 | Input Aux + VP 1 V ¹ |
| 3 | Input Aux + VT2 24 V ¹ |

| CT Input (H) | |
|--------------|-----------|
| 0 | Absent |
| 2 | CT1 + CT2 |

Note

- 1) Auxiliary input type 1 V / 5 V / 10 V / 20 mA
- 2) Auxiliary input type TC / RTD / 60 mV
- 3) Only for option H-I = 0
- 4) The N options require P = FB option
- 5) V and PV models required (CD) =RR

Check before each request a list of codes available on the following pages

ORDER METHODS

Power supply 100...240 VAC/VDC

| Code F | Model | Valves | Programmer | Inputs | | | | Outputs | | | | | | I/O AUX | | Communica-tions | | Logic + mathematical functions | Total Number of Outputs | | | |
|---------|----------------------------------|--------|------------|---------|----|--------------------|--------------------------|--------------------------|-------|-------|-----------|----------------|----------|------------|---------------------|--------------------------|---------------|--------------------------------|-------------------------|------------------|---|----------------|
| | | | | Digital | CT | AUX (TC/RTD/60mV) | AUX (1V/5V/10V/20mA) +VP | AUX (1V/5V/10V/20mA) +VT | Relay | Triac | Logic SSR | Logic isolated | Analog I | Analog V/I | Power supply sensor | Digital Inputs / Outputs | Outputs relay | | | RS485 modbus RTU | | |
| | | | | | | | | | | | | | | | | | | | | | | |
| F065321 | 1850-D-RVR-0-0-00-5-00-00-1-00 | | | 5 | | | | 2 | 1 | | | | | • | | | | | | | | 3 outputs |
| F065322 | 1850-R-RVR-0-0-00-5-00-00-1-00 | | | 5 | | | | 3 | | | | | | • | | | | | | | | |
| F067164 | 1850-R-DDR-0-0-01-5-00-00-1-FB | | | 5 | • | | | 2 | 2 | | | | | | | | | | | | • | 4 outputs |
| F065331 | 1850-R-DDR-0-0-03-5-00-00-1-FB | | | 5 | | | • | 2 | 2 | | | | | | | | | | | | • | |
| F067165 | 1850-R-DDR-0-0-01-5-M0-00-1-FB | | | 5 | • | | | 2 | 2 | | | | | | | | | | | • | • | |
| F065332 | 1850-R-DDR-0-0-03-5-M0-00-1-FB | | | 5 | | | • | 2 | 2 | | | | | | | | | | | • | • | |
| F067167 | 1850-C-RRR-0-0-01-5-00-00-1-FB | | | 5 | • | | | 3 | | | | 1 | | | | | | | | | • | |
| F067168 | 1850-C-RRR-0-0-03-5-00-00-1-FB | | | 5 | | | • | 3 | | | | 1 | | | | | | | | | • | |
| F065334 | 1850-D-RRR-0-0-20-0-M0-00-1-00 | | | | 2 | | | 3 | 1 | | | | | | | | | | | | • | |
| F065350 | 1850V-D-RRR-0-0-02-5-M0-00-1-00 | • | | 5 | | • | | 3 | 1 | | | | | | | | | | | | • | |
| F065355 | 1850P-D-RRR-0-0-00-5-00-00-1-00 | | • | 5 | | | | 3 | 1 | | | | | | | | | | | | | |
| F067169 | 1850P-D-RRR-0-0-01-5-00-00-1-FB | | • | 5 | • | | | 3 | 1 | | | | | | | | | | | | • | |
| F065361 | 1850P-D-RRR-0-0-03-5-00-00-1-FB | | • | 5 | | | • | 3 | 1 | | | | | | | | | | | | • | |
| F065370 | 1850PV-D-RRR-0-0-02-5-00-00-1-FB | • | • | 5 | | • | | 3 | 1 | | | | | | | | | | | | • | |
| F065330 | 1850-R-RRR-0-0-02-5-00-00-1-00 | | | 5 | | • | | 4 | | | | | | | | | | | | | | |
| F065348 | 1850V-R-RRR-0-0-02-5-00-00-1-00 | • | | 5 | | • | | 4 | | | | | | | | | | | | | | |
| F067172 | 1850V-R-RRR-0-0-01-5-00-00-1-00 | • | | 5 | • | | | 4 | | | | | | | | | | | | | | |
| F065349 | 1850V-R-RRR-0-0-03-5-00-00-1-00 | • | | 5 | | | • | 4 | | | | | | | | | | | | | | |
| F067173 | 1850-R-DDR-0-2-01-5-00-10-1-FB | | | 5 | • | | | 2 | 2 | | | 2 | | • | | | | | | | • | 4 (+8) outputs |
| F067174 | 1850-R-DDR-0-2-03-5-00-10-1-FB | | | 5 | | | • | 2 | 2 | | | 2 | | • | | | | | | | • | |
| F067175 | 1850-R-DDR-0-2-01-5-M0-01-1-FB | | | 5 | • | | | 2 | 2 | | | 2 | | • | • | | | | | | • | |
| F067176 | 1850-R-DDR-0-2-03-5-M0-01-1-FB | | | 5 | | | • | 2 | 2 | | | 2 | | • | • | | | | | | • | |
| F065368 | 1850P-R-RRR-0-0-00-5-00-10-1-FB | | • | 5 | | | | 4 | | | | | | • | | | | | | | • | |
| F067179 | 1850-R-RVR-0-2-01-5-M0-00-1-00 | | | 5 | • | | | 3 | | | | 2 | • | | | | | | | | • | 5 outputs |
| F065340 | 1850-R-RVR-0-2-03-5-M0-00-1-00 | | | 5 | | | • | 3 | | | | 2 | • | | | | | | | | • | |
| F065351 | 1850V-D-RRR-0-1-02-5-00-00-1-00 | • | | 5 | | • | | 3 | 1 | | | 1 | | | | | | | | | | |
| F065352 | 1850V-D-RRR-0-1-02-5-M0-00-1-00 | • | | 5 | | • | | 3 | 1 | | | 1 | | | | | | | | | • | |
| F067180 | 1850V-D-RRR-0-1-01-5-M0-00-1-00 | • | | 5 | • | | | 3 | 1 | | | 1 | | | | | | | | | • | |
| F065353 | 1850V-D-RRR-0-1-03-5-M0-00-1-00 | • | | 5 | | | • | 3 | 1 | | | 1 | | | | | | | | | • | |
| F065354 | 1850V-R-RR0-0-2-00-0-00-00-1-00 | • | | | | | | 3 | | | | 2 | | | | | | | | | | |
| F065364 | 1850P-D-RRR-0-1-02-5-M0-00-1-00 | | • | 5 | | • | | 3 | 1 | | | 1 | | | | | | | | | • | |
| F067181 | 1850-R-RRR-0-1-01-5-00-00-1-00 | | | 5 | • | | | 4 | | | | 1 | | | | | | | | | | |
| F065338 | 1850-R-RRR-0-1-03-5-00-00-1-00 | | | 5 | | | • | 4 | | | | 1 | | | | | | | | | | |
| F067182 | 1850-R-RRR-0-1-01-5-M0-00-1-00 | | | 5 | • | | | 4 | | | | 1 | | | | | | | | | • | |
| F065339 | 1850-R-RRR-0-1-03-5-M0-00-1-00 | | | 5 | | | • | 4 | | | | 1 | | | | | | | | | • | |
| F067183 | 1850P-R-RRR-0-1-01-5-M0-00-1-00 | | • | 5 | • | | | 4 | | | | 1 | | | | | | | | | • | |
| F065365 | 1850P-R-RRR-0-1-03-5-M0-00-1-00 | | • | 5 | | • | | 4 | | | | 1 | | | | | | | | | • | |

Note: Please contact GEFRA for information on available codes.

Power supply 100...240 VAC/VDC

| Code F | Model | Valves | Programmer | Inputs | | | | | Outputs | | | | | | I/O AUX | | Communica-tions | | Logic + mathematical functions | Total Number of Outputs | | | | | |
|---------|---------------------------------|--------|------------|---------|----|--------------------|--------------------------|--------------------------|---------|-------|-----------|----------------|----------|------------|---------------------|--------------------------|-----------------|------------------|--------------------------------|-------------------------|--|---|--|----------------|--|
| | | | | Digital | CT | AUX (TC/RTD/60mV) | AUX (1V/5V/10V/20mA) +VP | AUX (1V/5V/10V/20mA) +VT | Relay | Triac | Logic SSR | Logic isolated | Analog I | Analog V/I | Power supply sensor | Digital Inputs / Outputs | Outputs relay | RS485 modbus RTU | | | | | | | |
| F065341 | 1850-D-RRR-0-2-02-5-00-00-1-00 | | | 5 | | | • | | 3 | | 1 | | | | 2 | | | | | | | | | 6 outputs | |
| F067184 | 1850P-D-RRR-0-2-01-5-00-00-1-00 | | • | 5 | | • | | | 3 | | 1 | | | 2 | | | | | | | | | | | |
| F065366 | 1850P-D-RRR-0-2-03-5-00-00-1-00 | | • | 5 | | | | • | 3 | | 1 | | | 2 | | | | | | | | | | | |
| F065367 | 1850P-D-RRR-0-2-20-5-M0-00-1-00 | | • | 5 | 2 | | | | 3 | | 1 | | | 2 | | | | | | | | • | | | |
| F067185 | 1850-R-RRR-0-2-01-5-M0-00-1-00 | | | 5 | | • | | | 4 | | | | | 2 | | | | | | | | • | | | |
| F065342 | 1850-R-RRR-0-2-03-5-M0-00-1-00 | | | 5 | | | | • | 4 | | | | | 2 | | | | | | | | • | | | |
| F067187 | 1850P-R-RRR-0-2-01-5-M0-10-1-FB | | • | 5 | | • | | | 4 | | | | | 2 | | • | | | | | | • | | 6 (+8) outputs | |
| F065369 | 1850P-R-RRR-0-2-03-5-M0-10-1-FB | | • | 5 | | | • | | 4 | | | | | 2 | | • | | | | | | • | | | |

Note: Please contact GEFTRAN for information on available codes.

Power supply 20...27 VAC/VDC



| Code F | Model | Valves | Programmer | Inputs | | | | Outputs | | | | | | I/O AUX | Communica-tions | | Logic + mathematical functions | Total Number of Outputs | |
|---------|----------------------------------|--------|------------|---------|----|--------------------|--------------------------|--------------------------|-------|-------|-----------|----------------|----------|---------|-----------------|---------------------|--------------------------------|-------------------------|--------------------------|
| | | | | Digital | CT | AUX (TC/RTD/60mV) | AUX (1V/5V/10V/20mA) +VP | AUX (1V/5V/10V/20mA) +VT | Relay | Triac | Logic SSR | Logic isolated | Analog I | | Analog V/I | Power supply sensor | | | Digital Inputs / Outputs |
| F065269 | 1850-D-RVR-0-0-00-5-00-00-0-00 | | | 5 | | | | 2 | 1 | | | | | • | | | | | 3 outputs |
| F065270 | 1850-R-RVR-0-0-00-5-00-00-0-00 | | | 5 | | | | 3 | | | | | | • | | | | | |
| F067188 | 1850-R-DDR-0-0-01-5-00-00-0-FB | | | 5 | • | | | 2 | 2 | | | | | | | | | • | |
| F065279 | 1850-R-DDR-0-0-03-5-00-00-0-FB | | | 5 | | | • | 2 | 2 | | | | | | | | | • | |
| F067189 | 1850-R-DDR-0-0-01-5-M0-00-0-FB | | | 5 | • | | | 2 | 2 | | | | | | | | • | • | |
| F065280 | 1850-R-DDR-0-0-03-5-M0-00-0-FB | | | 5 | | | • | 2 | 2 | | | | | | | | • | • | |
| F067191 | 1850-C-RRR-0-0-01-5-00-00-0-FB | | • | 5 | • | | | 3 | | | | 1 | | | | | | • | |
| F067192 | 1850-C-RRR-0-0-03-5-00-00-0-FB | | • | 5 | | | • | 3 | | | | 1 | | | | | | • | |
| F065282 | 1850-D-RRR-0-0-20-0-M0-00-0-00 | | | | 2 | | | 3 | 1 | | | | | | | | • | | |
| F065298 | 1850V-D-RRR-0-0-02-5-M0-00-0-00 | • | | 5 | | • | | 3 | 1 | | | | | | | | • | | |
| F065303 | 1850P-D-RRR-0-0-00-5-00-00-0-00 | | • | 5 | | | | 3 | 1 | | | | | | | | | | |
| F067193 | 1850P-D-RRR-0-0-01-5-00-00-0-FB | | • | 5 | • | | | 3 | 1 | | | | | | | | | • | |
| F065309 | 1850P-D-RRR-0-0-03-5-00-00-0-FB | | • | 5 | | | • | 3 | 1 | | | | | | | | | • | |
| F065318 | 1850PV-D-RRR-0-0-02-5-00-00-0-FB | • | • | 5 | | • | | 3 | 1 | | | | | | | | | • | |
| F065278 | 1850-R-RRR-0-0-02-5-00-00-0-00 | | | 5 | | • | | 4 | | | | | | | | | | | |
| F065296 | 1850V-R-RRR-0-0-02-5-00-00-0-00 | • | | 5 | | • | | 4 | | | | | | | | | | | |
| F067196 | 1850V-R-RRR-0-0-01-5-00-00-0-00 | • | | 5 | • | | | 4 | | | | | | | | | | | |
| F065297 | 1850V-R-RRR-0-0-03-5-00-00-0-00 | • | | 5 | | | • | 4 | | | | | | | | | | | |
| F067197 | 1850-R-DDR-0-2-01-5-00-10-0-FB | | | 5 | • | | | 2 | 2 | | | 2 | | • | | | | • | |
| F067198 | 1850-R-DDR-0-2-03-5-00-10-0-FB | | | 5 | | | • | 2 | 2 | | | 2 | | • | | | | • | |
| F067199 | 1850-R-DDR-0-2-01-5-M0-01-0-FB | | | 5 | • | | | 2 | 2 | | | 2 | | • | • | | | • | |
| F067200 | 1850-R-DDR-0-2-03-5-M0-01-0-FB | | | 5 | | | • | 2 | 2 | | | 2 | | • | • | | | • | |
| F065316 | 1850P-R-RRR-0-0-00-5-00-10-0-FB | | • | 5 | | | | 4 | | | | | | • | | | | • | |
| F067203 | 1850-R-RVR-0-2-01-5-M0-00-0-00 | | | 5 | • | | | 3 | | | | 2 | • | | | | • | | |
| F065288 | 1850-R-RVR-0-2-03-5-M0-00-0-00 | | | 5 | | | • | 3 | | | | 2 | • | | | | • | | |
| F065299 | 1850V-D-RRR-0-1-02-5-00-00-0-00 | • | | 5 | | • | | 3 | 1 | | | 1 | | | | | | | |
| F065300 | 1850V-D-RRR-0-1-02-5-M0-00-0-00 | • | | 5 | | • | | 3 | 1 | | | 1 | | | | | • | | |
| F067204 | 1850V-D-RRR-0-1-01-5-M0-00-0-00 | • | | 5 | • | | | 3 | 1 | | | 1 | | | | | • | | |
| F065301 | 1850V-D-RRR-0-1-03-5-M0-00-0-00 | • | | 5 | | | • | 3 | 1 | | | 1 | | | | | • | | |
| F065302 | 1850V-R-RRR-0-2-00-0-00-00-0-00 | • | | | | | | 3 | | | | 2 | | | | | | | |
| F065312 | 1850P-D-RRR-0-1-02-5-M0-00-0-00 | | • | 5 | | • | | 3 | 1 | | | 1 | | | | | • | | |
| F067205 | 1850-R-RRR-0-1-01-5-00-00-0-00 | | | 5 | • | | | 4 | | | | 1 | | | | | | | |
| F065286 | 1850-R-RRR-0-1-03-5-00-00-0-00 | | | 5 | | | • | 4 | | | | 1 | | | | | | | |
| F067206 | 1850-R-RRR-0-1-01-5-M0-00-0-00 | | | 5 | • | | | 4 | | | | 1 | | | | | • | | |
| F065287 | 1850-R-RRR-0-1-03-5-M0-00-0-00 | | | 5 | | | • | 4 | | | | 1 | | | | | • | | |
| F067207 | 1850P-R-RRR-0-1-01-5-M0-00-0-00 | | • | 5 | • | | | 4 | | | | 1 | | | | | • | | |
| F065313 | 1850P-R-RRR-0-1-03-5-M0-00-0-00 | | • | 5 | | | • | 4 | | | | 1 | | | | | • | | |

Note: Please contact GEFTRAN for information on available codes.

Power supply 20...27 VAC/VDC

| Code F | Model | Valves | Programmer | Inputs | | | | Outputs | | | | | | I/O AUX | Communica-tions | | Logic + mathematical functions | Total Number of Outputs | | | |
|---------|---------------------------------|--------|------------|---------|----|--------------------|--------------------------|--------------------------|-------|-------|-----------|----------------|----------|---------|-----------------|---------------------|--------------------------------|-------------------------|--------------------------|---------------|------------------|
| | | | | Digital | CT | AUX (TC/RTD/60mV) | AUX (1V/5V/10V/20mA) +VP | AUX (1V/5V/10V/20mA) +VT | Relay | Triac | Logic SSR | Logic isolated | Analog I | | Analog V/I | Power supply sensor | | | Digital Inputs / Outputs | Outputs relay | RS485 modbus RTU |
| F065289 | 1850-D-RRR-0-2-02-5-00-00-0-00 | | | 5 | | | • | | 3 | | 1 | | | 2 | | | | | | | 6 outputs |
| F067208 | 1850P-D-RRR-0-2-01-5-00-00-0-00 | | • | 5 | | • | | 3 | | 1 | | | 2 | | | | | | | | |
| F065314 | 1850P-D-RRR-0-2-03-5-00-00-0-00 | | • | 5 | | | • | 3 | | 1 | | | 2 | | | | | | | | |
| F065315 | 1850P-D-RRR-0-2-20-5-M0-00-0-00 | | • | 5 | 2 | | | 3 | | 1 | | | 2 | | | | • | | | | |
| F067209 | 1850-R-RRR-0-2-01-5-M0-00-0-00 | | | 5 | | • | | 4 | | | | | 2 | | | | • | | | | |
| F065290 | 1850-R-RRR-0-2-03-5-M0-00-0-00 | | | 5 | | | • | 4 | | | | | 2 | | | | • | | | | |
| F067211 | 1850P-R-RRR-0-2-01-5-M0-10-0-FB | | • | 5 | | • | | 4 | | | | | 2 | | • | | • | | | • | 6 (+8) outputs |
| F065317 | 1850P-R-RRR-0-2-03-5-M0-10-0-FB | | • | 5 | | | • | 4 | | | | | 2 | | • | | • | | | • | |

Note: Please contact GEFRAN for information on available codes.

| | |
|---|--|
|  | Conformity C/UL/US File no. E216851 |
|  | EMC: Compliance with Directive 2014/30 / EU, with reference to EN 61326-1 emission in industrial environment class A Security LVD: Compliance with Directive 2014/35 / EU, with reference to EN 61010-1 |