

#### Main applications

- Industrial furnaces for heat treatments, metallurgy
- Fusion, sinterization, nitriding furnaces
- Furnaces for ceramics and precious metals
- Dryers
- Heating systems with monophase and triphase transformers
- Heating systems with Super Kanthal™ resistors
- Heating systems with Silicon carbide resistors

#### Main features

- Current capacities from 40 A up to 600 A, 480 Vac, 600 Vac, 690 Vac
- Synchronised Single-Bi-Three phase configurations
- Firing mode configurable in “Zero crossing” ( Fixed Cycle, Burst Firing, Half Single Cycle ) and “Phase angle”
- Analogue control inputs configurable in Volt, mA, potentiometer and digital “PWM”
- Settable retransmission analogue outputs
- Optional inputs from external TA and TV
- Current limits
- Feedback V, V2, I, I2, P
- Optional built-in PID temperature controller
- Total and partial interrupted load alarms with Relay outputs
- Built-in fuses
- Temperature sensors on Power terminals and air inlet
- Fieldbus: PROFINET, Profibus, Modbus TCP/RTU, Ethernet IP, EtherCAT, Canopen
- Configuration keyboard and monitor
- PC configuration tool with configuration wizard ( SMART )
- CE, UL, CSA certifications and SCCR UL 508 100KA approvals

#### PROFILE

**GFW** Electric Power Controllers provide complete Single-Bi-Three phase modular solutions from 40 A up to 600 A per phase, suited to manage linear and non linear loads for electric heating in a wide range of industrial applications, equipped with easy to replace on-board fuses and settable analogue outputs to retransmit controlled variables.

#### UNIVERSAL COMMANDS

The construction flexibility allows you to control **GFW** controllers with analogue signals in 0-10V voltage, 4-20mA current, with potentiometers, with ON/OFF linear signals or in PWM mode.

Single signals allow you to control Bi-phase and Three-phase models even as single independent single-phase. The control power values can also be directly sent via one of the multiple available Fieldbus, with convenient cascading IN/OUT connections.

#### CONTROL FUNCTIONS

To adapt to the multiple possible applications, even the Power module firing choice can be set on the product; you can choose between various types of “Zero crossing” with fixed cycle times or optimised for linear loads and high heat inertia systems, or for fast firing modes, like the Half Single Cycle and Phase angle, to better control non linear loads like SWIR infrared lamps, Super Kanthal and Silicon carbide heating elements or single and three-phase transformer primaries directly. Soft Start, current limits settable for both peak values and RMS values and closed loop Voltage, Current and Power feedback algorithms complete the control. A universal PID temperature controller can be built into some models to optimise space and costs and manage a temperature and power control loop with a single device.

#### DIAGNOSTICS, PREVENTIVE MAINTENANCE AND ALARMS

Some of the strengths of this range include the multiple diagnostic functions, preventive maintenance and alarms for current, voltage and temperature.

##### Current

- Total and partial interrupted load alarm with alarm threshold auto-learning.
- SCR short circuit alarm.
- Short circuit or surge load alarm.
- Broken internal fuse alarm.

##### Voltage

- No voltage alarm.
- Incorrect rotation of the three phases alarm in three-phase systems.
- Unbalanced three-phase line alarm

##### Temperature

- Power module temperature monitoring with automatic off in the event of overheating alarm.
- Temperature measurement of all Power terminals with loosened connection alarm.
- Fan output temperature measurement for cooling efficiency diagnostics.
- No fan power alarm.

## CONFIGURATIONS

Optimal parameter settings are possible through a local programming keyboard, the **GFW-OP**, that also manages variable monitor functions, or PC configuration tool, **GF-express**, that offers simple and fast configuration wizards via the "Smart Configuration" menu. You can create and save entire parameter recipes and easily copy them to other devices with **GF-express** in addition to monitoring parameters and viewing them in a graph with the oscilloscope function.

## FIELD BUS

A Modbus RTU port is always available, for both connections with the configuration tool and with HMI or PLC devices with Modbus Master communications. An extensive range of Fieldbus options let you add **GFW** controllers in control architectures with the most popular PLC brands, letting you access any device variable.

## MODELS

### General features:

Nominal voltage: 480 or 600V or 690V  
Nominal current: 40, 60, 100, 150, 200, 250 Arms @ 40°C in continuous service.  
Nominal current: 400, 600 Arms @ 50°C in continuous service.

### Isolation HV

Rated isolation voltage input/output:  
4000 Vac

## INPUTS

### Control analog input

N.1 input (for model GFW40-250A)  
N.3 inputs (for model GFW400-600A)  
Voltage: 5Vdc, 10Vdc  
Current: 0...20mA, 4...20mA  
Potentiometer: From 1KΩ to 10KΩ (auto-fed by 5V from GFW)

### Digital inputs

N.3 inputs (for model GFW40-250A)  
N.4 inputs (for model GFW400-600A)  
Range 5-30V max 7mA  
PWM input control: 0,03...100Hz  
(Configurable Features).

### PID inputs

(Optional, only for GFW40-250A)  
Configurable with TC input: type J, K, R, S, T, custom, PT100 RTD input  
Voltage input: 60 mV, 1V  
Current input: 0-20 mA, 4-20mA

### TC AUX inputs

(Optional, only for GFW40-250A)  
N. 4 configurable input: type TC J, K, R, S, T, or 60 mVdc Linear input

### Voltage line range

Range: 90V... V\_nominal\_product  
Frequency: 50-60Hz

### Current load range:

Range: 0... 2\*I\_nominal\_product

### External current transformer inputs:

(optional, only for GFW400-600A)  
3 5Aac inputs(read f.s. settable with SW configuration parameter)

### Key HB:

HB alarm calibration ON or reset memory alarms.

## OUTPUTS

Power output, function mode:

**ZC** – Zero Crossing fixed cycle time

**BF** – Burst Firing

(Zero-crossing minimum optimize cycle time)

### **HSC** – Half Single Cycle

(Zero-crossing corresponds to Burst Firing that manages single semi-cycles of conduction or stop cycles.)

### **PA** – Phase Angle

### Potentiometer power outputs:

5 Vdc, 10mA max for models  
GFW 40-250A

5 Vdc, 30mA max for models  
GFW 400-600A

## ALARM OUTPUTS

### For models GFW 40-250A

2 Relays NO contact (OUT9-10)  
4 Optional outputs - Relay, Triac, Continuous, Digital (OUT 5-6-7-8)

### For models GFW 400-600A

2 Relays with changeover contact  
C-NO-NC (OUT9-10)  
4 Optional outputs - Relay, Digital (OUT 5-6-7-8)  
3 Optional analog outputs 10V/20mA  
12 bit (OUT 5-6-7)

### Thermic Dissipation

GFW models dissipate thermic power based on load current:  
 $P_{dissipation} = I_{load\_Arms} * 1.3V (W)$

### Protective fuse

Installed inside product (optional)

### LED

N. 8 LEDs state indicator (Configurable)

### Modbus RS485 Serial (PORT1)

This lets you connect the GFW to a PLC or HMI via a simple RJ10 telephone wire by using an RS485 serial line with Modbus protocol. The Baud-Rate is configurable from 1200 Baud to 115000 Baud.

A pair of rotary-switches lets you quickly assign the node address.

A dip-switch lets you internally insert the line termination resistance.

### FieldBus Serial PORT2 (optional)

At the bottom of the device (front for GFW400/600A) you can insert one of the following optional.

For GFW 40-250A and GFW 400-600A models: Modbus RTU, Modbus TCP, Profibus DP, PROFINET, CanOpen, Ethernet IP, EtherCAT.

## GFW-OP Serial Keypad

A DB9 connector lets you connect the GFW to the Gefran GFW-OP keypad (optional) for parameter configuration and device supervision.

### Installation notes:

- To assure maximum reliability, it is essential to install the unit correctly in the panel in order to guarantee adequate heat exchange between the heat sink and the room under natural convection conditions.
- Install the unit vertically (max 10° inclination from vertical axis).
- Vertical distance between unit and panel wall >100mm
- Use the high speed fuses specified in the catalog
- Applications with solid state power units must also include an automatic safety switch to cut out the load power line.

### Limits of use

- Dissipation of thermic power on the device with restraints on the ambient temperature of the installation.
- Equip the cabinet with an external air change or air-condition it, to put out dissipated power.
- Line transistor max. voltage and derivative limits, for which the solid state relay is equipped with inside safety devices (based on the models)
- Presence of load current dispersion range 5-20mA depending on model) in absence of thyristor conduction due to internal RC protections.

## DERATING KURVEN

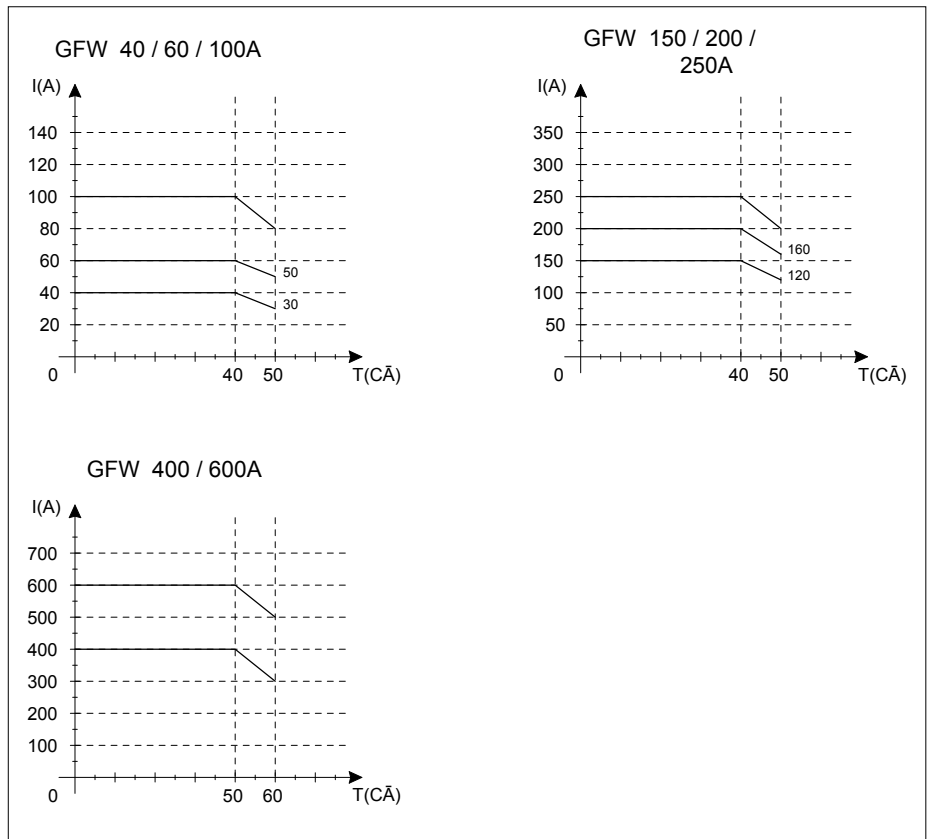

## FUNCTION MODE

### Trigger modes

The GFW provides the following power control modes:

- modulation via variation of phase angle: PA modality
- modulation via variation of number of conduction cycles with "zero crossing" trigger": ZC, BF, HSC modality.

### PA - Phase angle

This mode manages power on the load by modulating load phase angle

ex: if power to be transferred to the load is 100%,  $\theta = 180^\circ$

ex: if power to be transferred to the load is 50%,  $\theta = 90^\circ$

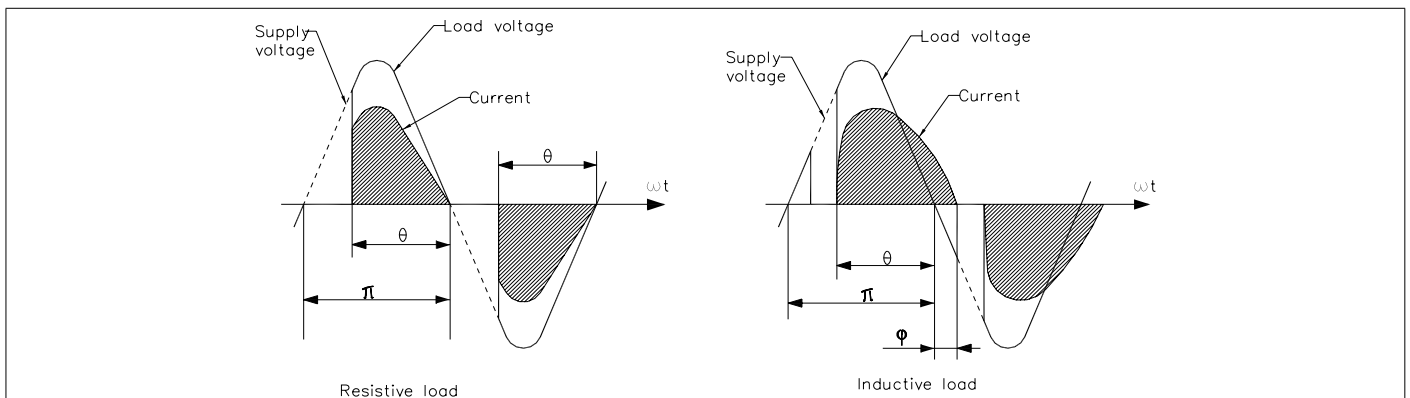

**Zero Crossing mode**

This function eliminates EMC noise. This mode controls power on the load via a series of conduction ON and non conduction OFF cycles.

**ZC** - Zero Crossing constant cycle time ( $T_c \geq 1$  sec, settable from 1 to 200 sec) Cycle time is divided into a series of conduction and non conduction cycles in proportion to the power value to be transferred to the load.

For example, if  $T_c = 10$ sec, if the power value is 20% there is conduction for 2 sec (100 conduction cycles @ 50Hz) and non conduction for 8 sec (400 non conduction cycles @ 50Hz).

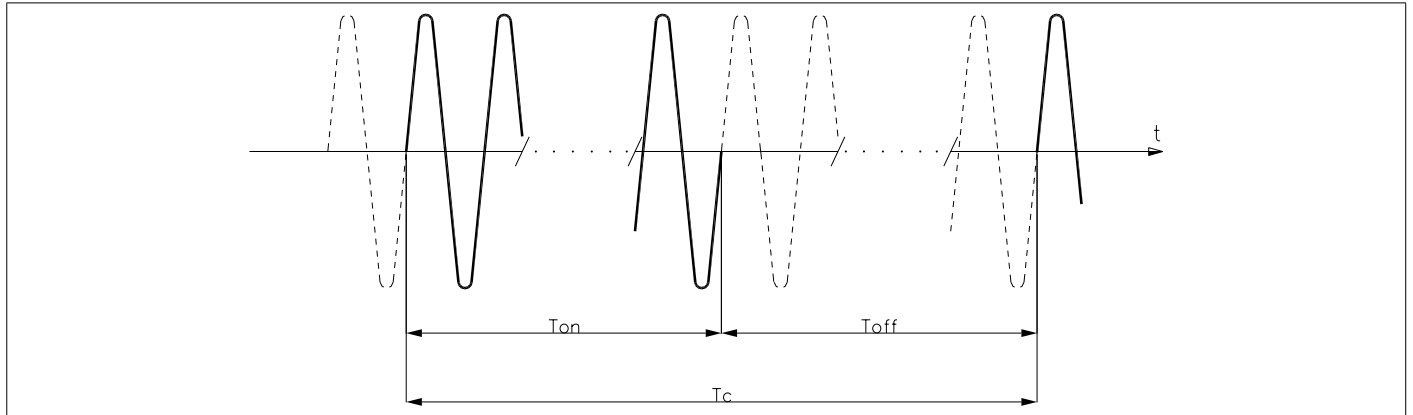

**BF** - Burst Firing, Zero Crossing variable cycle time.

This mode controls power on the load via a series of conduction ON and non conduction OFF cycles. The ratio of the number of ON cycles to OFF cycles is proportional to the power value to be supplied to the load.

The CT repeat period is kept to a minimum for each power value (whereas in ZC mode the period is always fixed and not optimized)

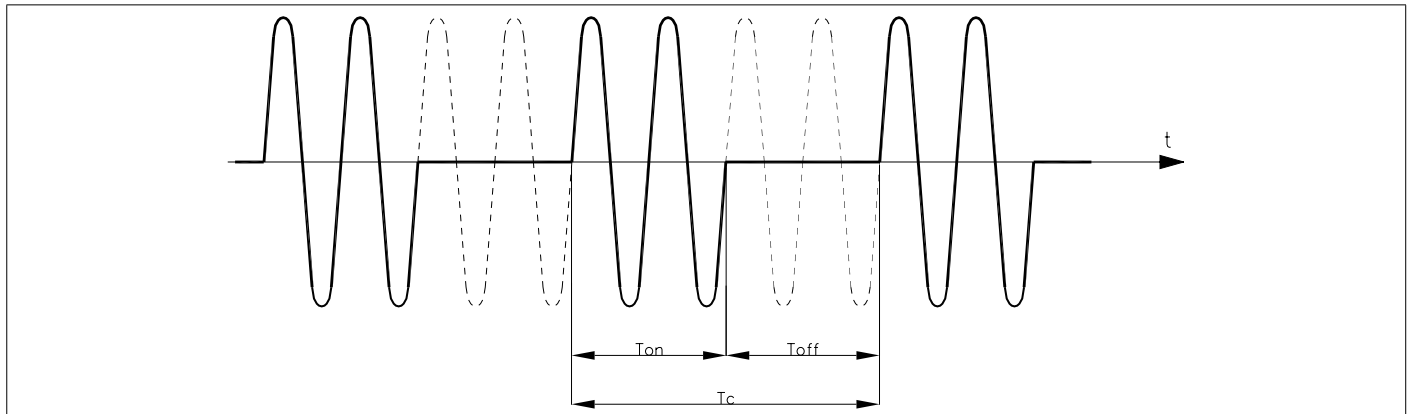

Example of operation in BF mode with power at 50%.

A parameter defines the minimum number of conduction cycles settable (from 1 to 10). In the example, this parameter = 2.

**HSC** - Half single cycle

This mode corresponds to Burst Firing that manages Semi-cycles of on and off.

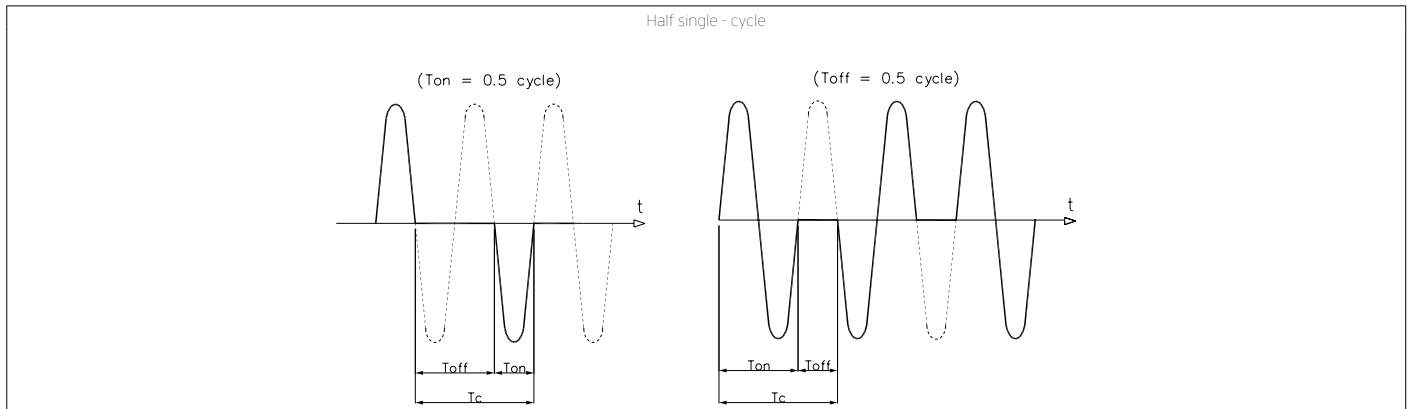

Ex function in modality HSC with power to 33 and 66%.

### Softstart at power-on

This type of start can be enabled in either phase control or pulse train mode. With phase control, the increment of firing angle  $\theta$  stops at the corresponding power value to be transferred to the load.

The control of maximum current spike can be enabled during the ramp phase (this is useful in case of short circuit on the load or loads with other temperature coefficients to automatically adjust the start time of the load).

The ramp is automatically re-enabled if the GFW remains off for a (settable) time.

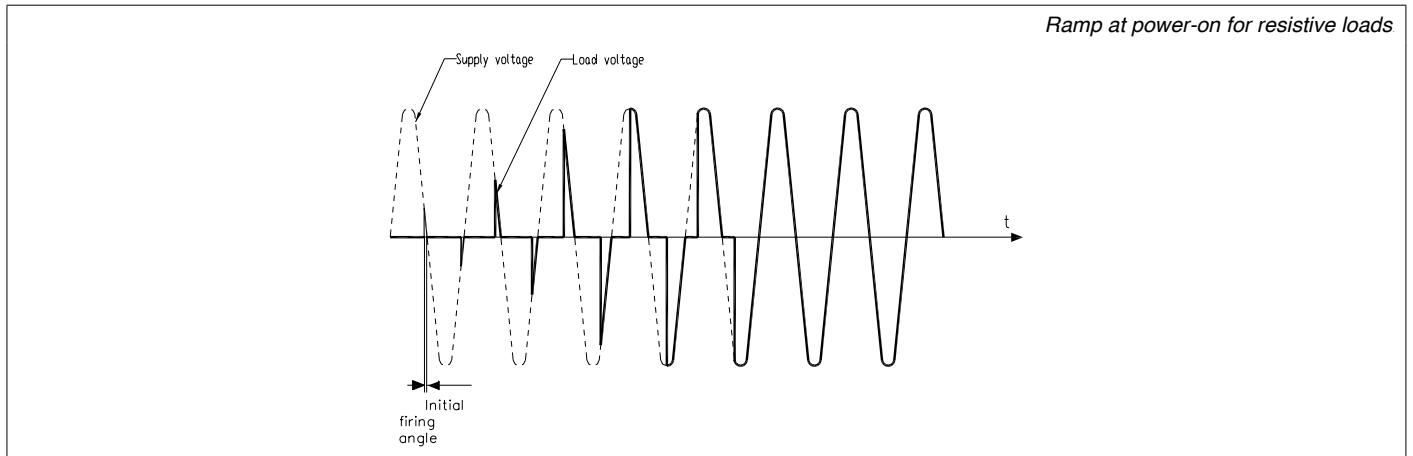

**DT** - "Delay triggering" of first cycle (only for control modes ZC, BF) Settable from  $0^\circ$  to  $90^\circ$ .

Useful for inductive loads (transformer primaries) to prevent current spike that could in certain cases trip the high-speed fuses that protect the SCRs.

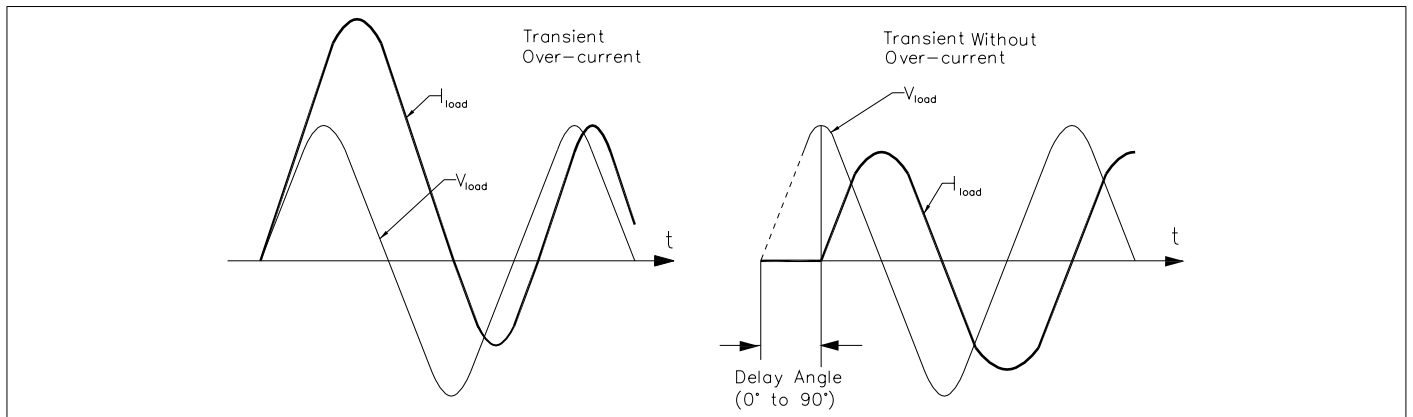

# DESCRIPTION OF CONNECTIONS (for models GFW 40-250A)

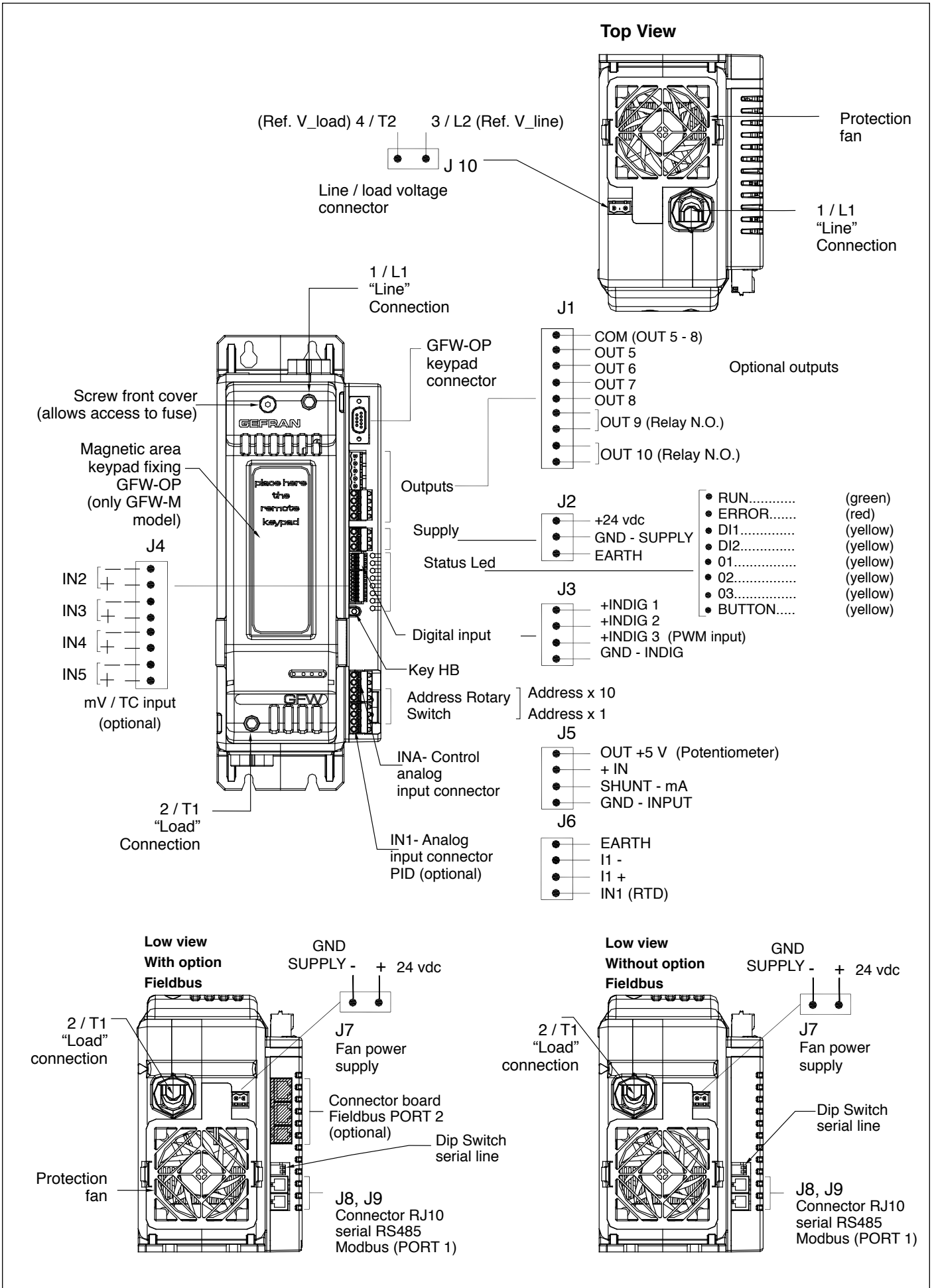

# DESCRIPTION OF CONNECTIONS (for models GFW400-600A)

**Top View**

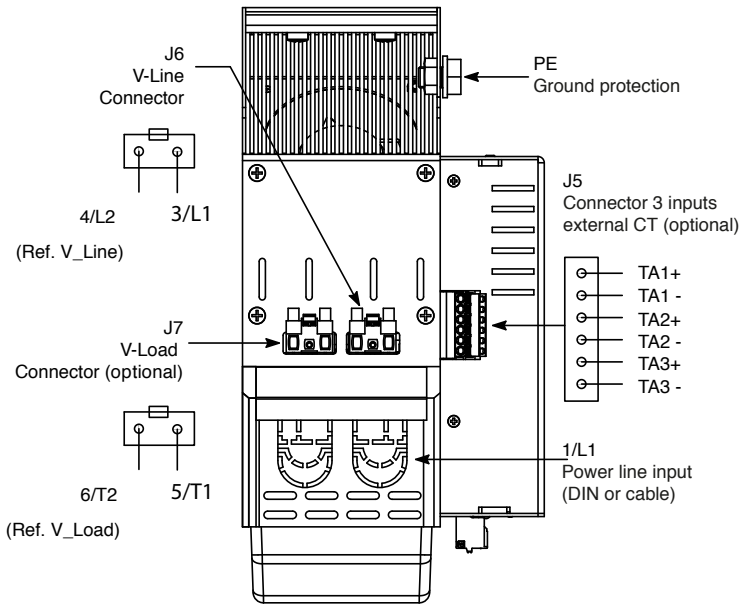

**Bottom View**

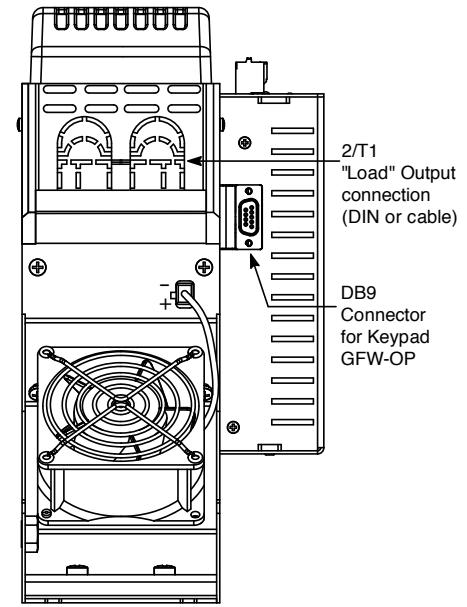

**Front View**

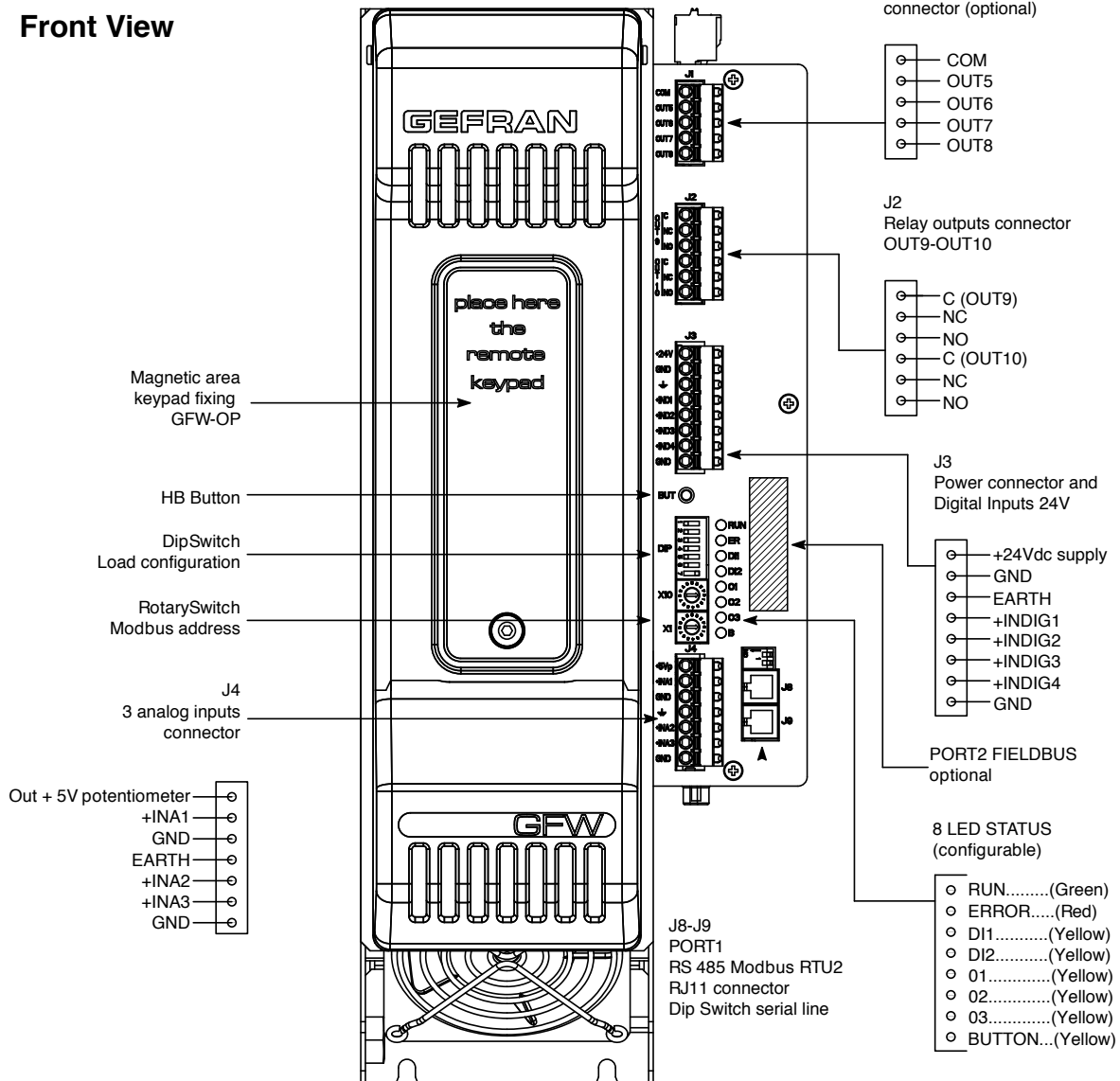

# DIMENSIONS (models GFW 40-250A)

**GFW MASTER**

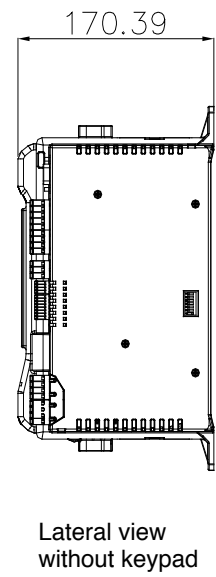
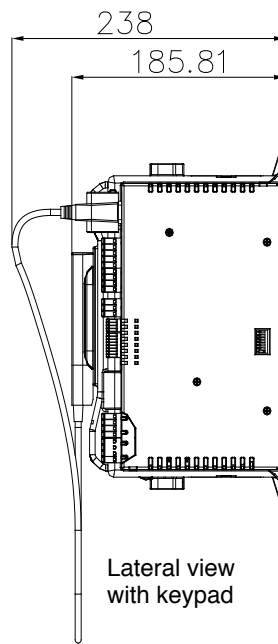
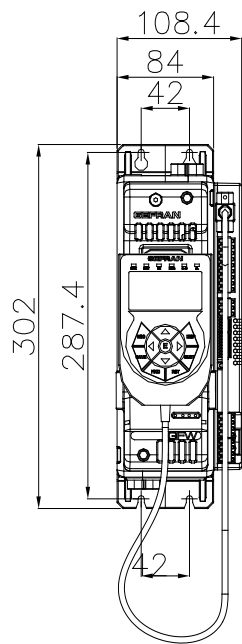

**GFW DUAL-PHASE  
(Master + 1 Expansion)**

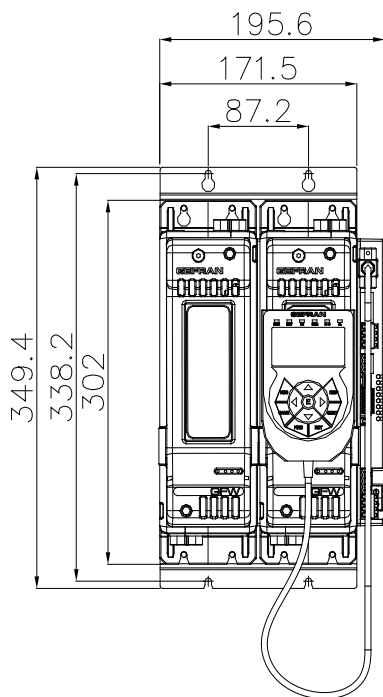

**GFW THREE-PHASE  
(Master + 2 Expansions)**

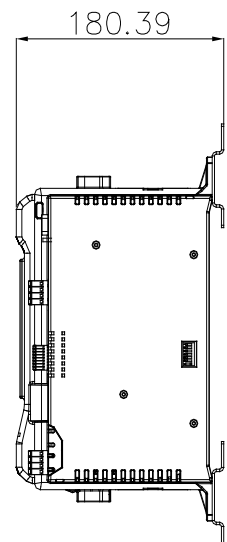
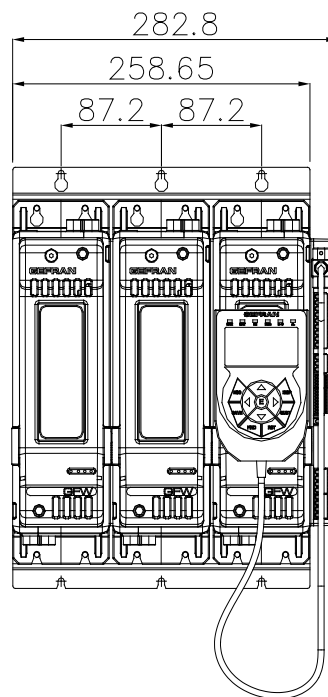



# DIMENSIONS (models GFW 400-600A)

## GFW MASTER

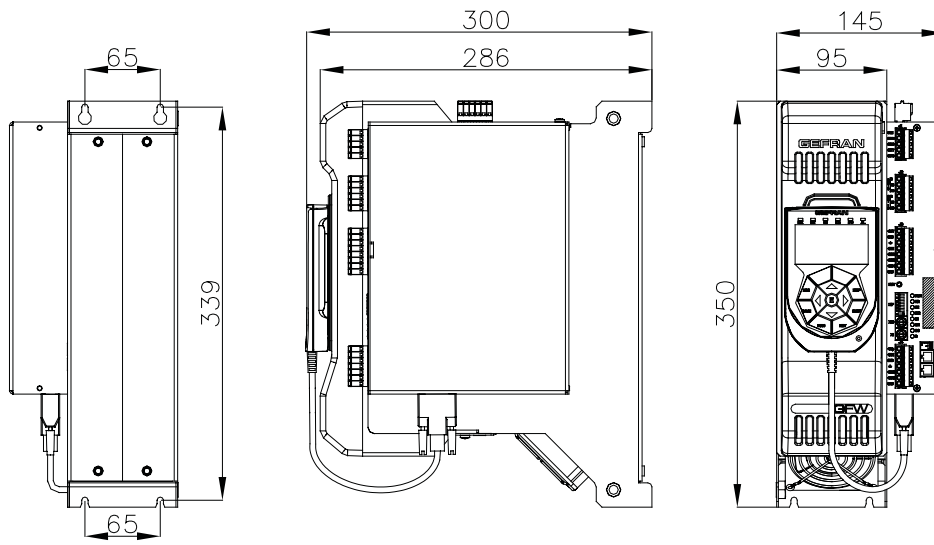

## GFW DUAL-PHASE

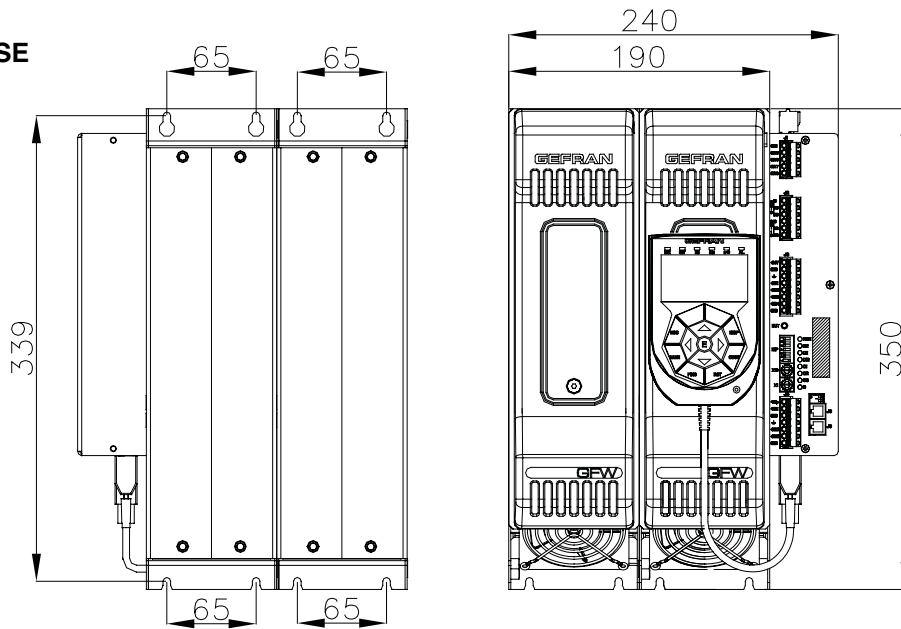

## GFW THREE-PHASE

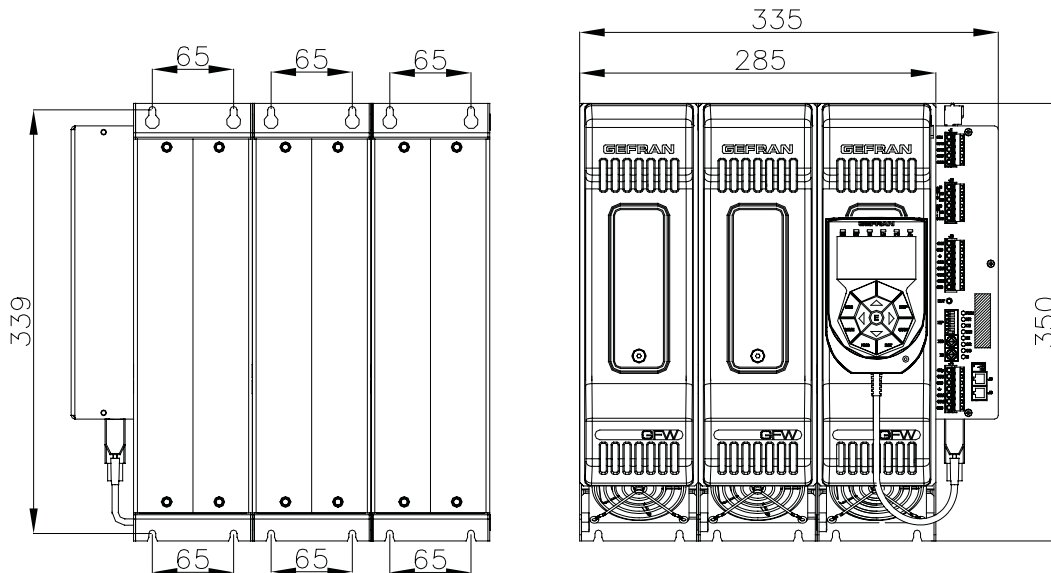

## TEMPLATE DIMENSIONS (models GFW 40-250A)

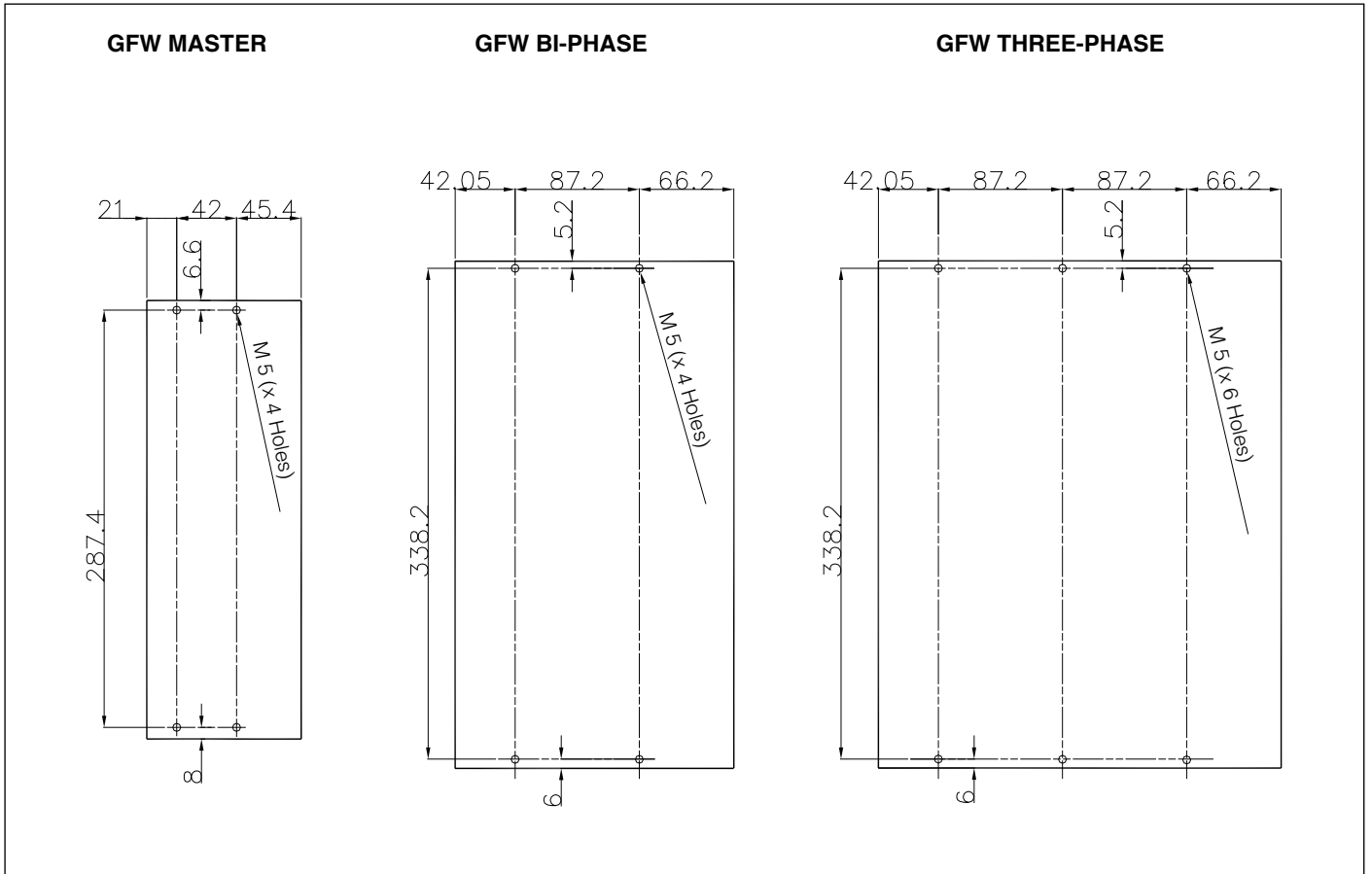

Fastening may be done with (5MA). All dimensions are expressed in mm.

## TEMPLATE DIMENSIONS (models GFW 400-600A)

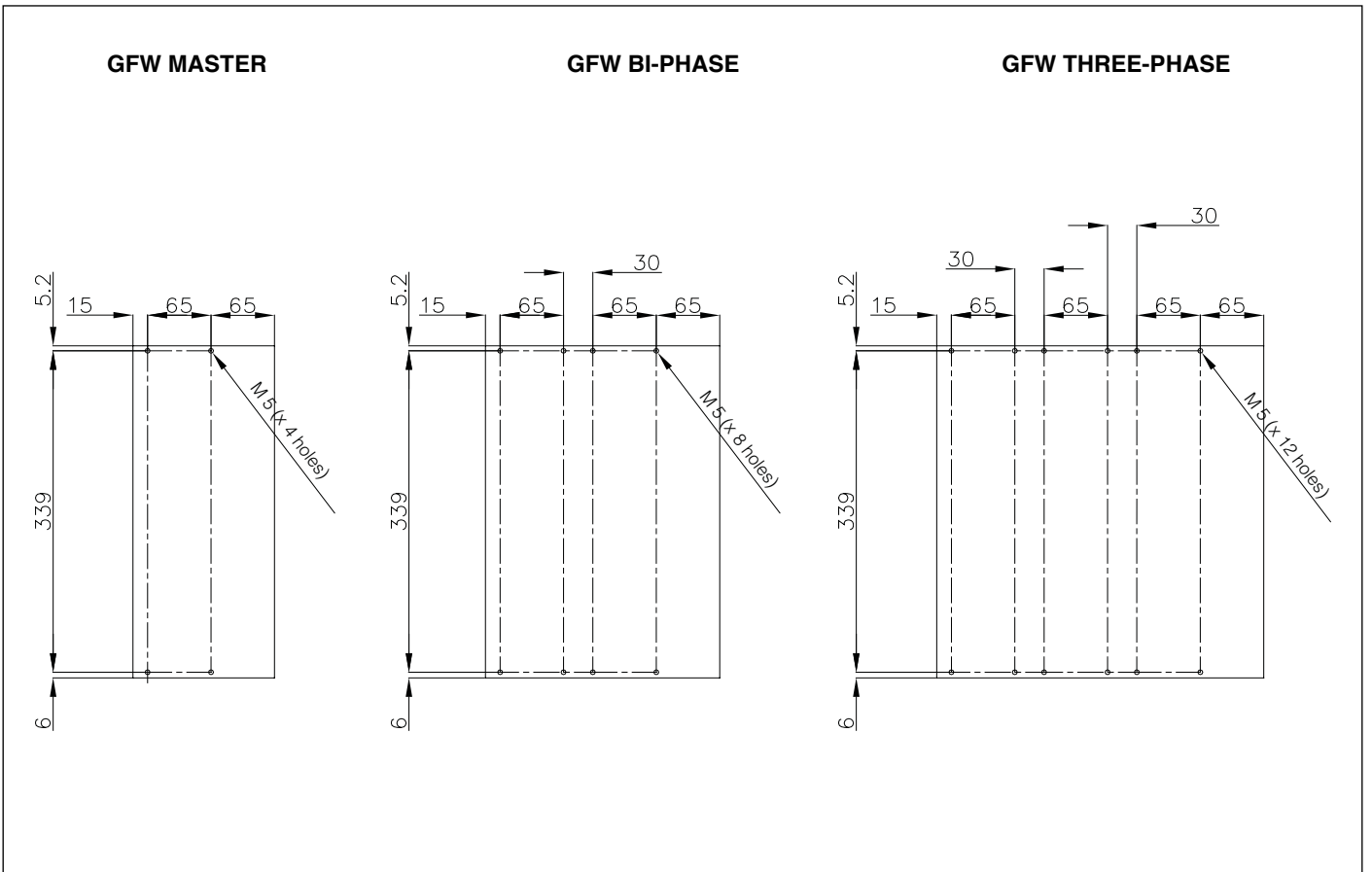

# TECHNICAL DATA

## General features

Category of use:

AC51, AC55b, AC56a

## Load type:

**AC51** resistive or low-inductance loads

**AC55b** short-wave infrared lamp (SWIR)

**AC56a** transformers, resistive loads with high temperature coefficient.

## Trigger mode:

**PA** - load control via adjustment of firing phase angle

**ZC** - Zero Crossing with constant cycle time (settable in range 1-200sec)

**BF** - Burst Firing with variable cycle time (GTT) optimized min.

**HSC** - Half Single Cycle corresponds to Burst Firing that includes ON and OFF half-cycles.

Useful for reducing flicker with shortwave IR loads (applied only to calibrate each time you change feedback mode.

## Nominal voltage:

480 Vac (max range 90-530 Vac)

600 Vac (max range 90-660 Vac)

690 Vac (max range 90-760 Vac)

Nominal frequency: 50-60Hz

## Non-repetitive voltage:

1200Vpk (models 480 Vac)

1600Vpk (models 600 Vac/690 Vac)

## Control analog input:

Voltage: 0...5Vdc, 0...10Vdc

(impedance>100KΩ)

Current: 0...20mA, 4...20mA

(impedance 125Ω)

Potentiometer: from 1KΩ to 10KΩ

(auto-fed by 5V by GFW)

## Digital inputs

Range 5-30V max 7mA

PWM input control: 0,03...100Hz

(PWM functionality configurable:

- for models GFW40-250A only with INDIG 3;

- for models GFW400-600A only with INDIG 1,2,3).

## PID input

Sampling time: 60msec

Accuracy: 0,2% FS ±1 scale points 25°C.

Thermal drift: <100ppm/°C scale points.

Type:

• Thermocouples ITS90: J, K, R, S, T, custom (IEC584-1, CEI EN 60584-1,60584-2)

Internal cold junction compensation with automatic compensation.

Selectable temperature range: °C/°F

• Thermoresistance: Pt100 DIN 43760

Max. resistance 20Ω

Selectable temperature range: °C/°F

• Voltage: range 0/12...60mV, Ri > 1MΩ  
0/0,2...1V, Ri > 1MΩ custom linearization at 32 sections

• Current: range 0/4...20mA, Ri = 50Ω  
custom linearization at 32 sections

## TC AUX input

Sampling time: 480msec

Accuracy: 1% FS ±1 scale point 25°C.

Type:

• Thermocouples ITS90: J, K, R, S, T, custom (IEC584-1, CEI EN 60584-1, 60584-2)

Internal cold junction compensation with automatic compensation..

• Voltage: range 0/12...60mV, Ri > 1MΩ

## Voltage line range

Range: 90... V\_nominal\_product

Frequency: 50-60Hz

Accuracy: 1% f.s with neutral connected,

2% f.s. without neutral connected

## Voltage load range:

Accuracy: 1% f.s with load voltage measurement option (VLOAD option)

Accuracy: 2% f.s without option VLOAD

## Current load range

measures RMS value

Accuracy: 2% f.s at room temperature of 25°C. Sampling time: 0.25msec

## Measurement of external current transformer:

(Option available only for GFW400-600A)

Input f.s.: 5A rms

Input impedance: 16 mΩ

Accuracy: 2% f.s. at room temperature of 25°C

Sampling time: 0.25msec

SW parameter to set current transformer transformation ratio in range 1...655 (allows measurement of current to secondary up to 3275A).

## HB alarm output (optional)

The HB function detects partial or total load interruption.

The control measures load current by means of an internal device.

The current limit value is set via an automatic procedure activated with the HB button located near the upper connector.

The alarm output is obtained by means of outputs OUT 9-10 (or OUT 5-8).

## RS485 serial (PORT1)

Double RJ10 connector

RTU RS485 Modbus Protocol

Baud-Rate configurable from 1200 Baud to 115000 Baud

Pair of rotary-switches for node address.

Dip-switch for insertion of line termination resistance. Isolation 1500V

## Field bus (PORT2)

Protocol:

Modbus RTU \_\_\_\_\_ 115Kbps

CANopen \_\_\_\_\_ 10K...1Mbps

Profibus DP \_\_\_\_\_ 9,6...12Mbps

Ethernet IP/Modbus TCP 10/100Mbps

EtherCAT \_\_\_\_\_ 10/100Mbps

PROFINET \_\_\_\_\_ 10/100Mbps

## OUTPUTS

### Isolation HV

Rated isolation voltage input/output:

4000 Vac

### GFW 40

Nominal current 40 Arms @ 40°C in continuous service

Non-repetitive overcurrent t=10ms:

1400 A

I<sup>2</sup>t for blowout: 10000 A<sup>2</sup>s

dV/dt critical: 1000 V/μs

### GFW 60

Nominal current 60 Arms @ 40°C in continuous service

Non-repetitive overcurrent t=10ms: 1500 A

I<sup>2</sup>t per fusione: 12000 A<sup>2</sup>s

dV/dt critica: 1000V/μs

### GFW 100

Nominal current 100 Arms @ 40°C in continuous service

Non-repetitive overcurrent t=10ms: 1900 A

I<sup>2</sup>t for blowout: 18000 A<sup>2</sup>s

dV/dt critical: 1000V/μs

100KA SCCR

### GFW 150

Nominal current 150 Arms @ 40°C in continuous service.

Non-repetitive overcurrent t=10ms:

5000 A

I<sup>2</sup>t for blowout: 125000 A<sup>2</sup>s

dV/dt critical: 1000V/μs

### GFW 200

Nominal current 200 Arms @ 40°C in continuous service.

Non-repetitive overcurrent t=10ms:

8000 A

I<sup>2</sup>t for blowout: 320000 A<sup>2</sup>s

dV/dt critical: 1000V/μs

100KA SCCR

**GFW 250**

Nominal current 250 Arms @ 40°C in continuous service.

Non-repetitive overcurrent t=10ms:  
8000 A

I²t for blowout: 320000 A²s

dV/dt critical: 1000V/µs

100KA SCCR

**GFW 400**

Nominal current 400 Arms @ 50°C in continuous service.

Non-repetitive overcurrent t=10ms:

15.000 A

I²t for blowout: 1.125.000 A²s

dV/dt critical: 1000V/µs

**GFW 600**

Nominal current 600 Arms @ 50°C in continuous service.

Non-repetitive overcurrent t=10ms:

15.000 A

I²t for blowout: 1.125.000 A²s

dV/dt critical: 1000V/µs

**Thermic Dissipation:**

GFW models dissipate thermic power based on load current:

$P_{dissipation} = I_{load\_Arms} * 1.3V \text{ (W)}$

For models with integrated fuse, also consider dissipated power at rated current shown on the fuse table.

**LED**

N. 8 LEDs indicator:

(All LEDs are configurable via SW, the Default configuration provides):

RUN (green) RUN state of the CPU ERROR (red) error

DI1 (yellow) DI1digital input state

DI2 (yellow) DI2digital input state

O1 (yellow) Out.1 main input state

O2 (yellow) Out.2 main input state

O3 (yellow) Out.3 main input state

BUTTON (yellow) State Key HB

**POWER SUPPLY**

**for models GFW 40-250A:**

**CPU Power supply**

24Vdc/±10% max.10VA

**Cooling Fan Power Supply**

**(for each module PWR)**

24Vdc/±10%

Input @ 24 Vdc: max 500 mA

**POWER SUPPLY**

**for models GFW 400-600A :**

**GFW 1PH Power supply**

24Vdc/±10% max. 38 W

**GFW 2PH Power supply**

24Vdc/±10% max. 66 W

**GFW 3PH Power supply**

24Vdc/±10% max. 94 W

**Ambient conditions**

Working temperature: 0-50°C (see the derating curve)

Storage temperature:-20°C - +85°C

Max. relative humidity: 85% UR non-condensing

Max. installation altitude: 2000m above mean sea level

Installation requirements: Installation category II, pollution level 2, double isolation  
Max. temperature of air surrounding device 40°C for temperature > 40°C refer at derating curves

- Device type: "UL Open Type"

Installation: panel with screws

Dimensions: see dimensions and installation

**Weight**

models consider with integrated fuse:

GFW-1PH 40/60/100 A 2.2 Kg

GFW-2PH 40/60/100 A 4.2 Kg

GFW-3PH 40/60/100 A 6.2 Kg

GFW-1PH 150/200/250 A 2.6 Kg

GFW-2PH 150/200/250 A 5.0 Kg

GFW-3PH 150/200/250 A 7.4 Kg

GFW- 1PH 400/600 A 11 Kg

GFW- 2PH 400/600 A 21 Kg

GFW- 3PH 400/600 A 31 Kg

# ELECTRICAL CONNECTIONS for models GFW 40-250A





## POWER CONNECTIONS

### RECOMMENDED WIRE GAUGES

GFW CURRENT LEVEL	TERMINAL	WIRE GAUGE	TERMINAL TYPE	TIGHTENING / TOOL TORQUE
40 A	1/L1, 2/T1	10 mm <sup>2</sup> 7 AWG	Wire stripped for 25 mm or with crimped pre-insulated terminal tube CEMBRE PKC1018	5 Nm / Flat-head screwdriver tip 1 x 5.5 mm
60 A	1/L1, 2/T1	16 mm <sup>2</sup> 5 AWG	Wire stripped for 25 mm or with crimped pre-insulated terminal tube CEMBRE PKC1618	5 Nm / Flat-head screwdriver tip 1 x 5.5 mm
100 A	1/L1, 2/T1,	35 mm <sup>2</sup> 2 AWG	Wire stripped for 25 mm or with crimped pre-insulated terminal tube CEMBRE PKC35025	5 Nm / Flat-head screwdriver tip 1 x 5.5 mm
150 A	1/L1, 2/T1	70 mm <sup>2</sup> 2/0 AWG	Wire stripped for 25 mm or with crimped pre-insulated terminal tube CEMBRE PKC70022	6 Nm / hex head wrench N. 6
200 A	1/L1, 2/T1	95 mm <sup>2</sup> 4/0 AWG	Wire stripped for 25 mm or with crimped pre-insulated terminal tube CEMBRE PKC95025	6 Nm / hex head wrench N. 6
250 A	1/L1, 2/T1	120 mm <sup>2</sup> 250 Kcmil	Wire stripped for 25 mm	6 Nm / hex head wrench N. 6
---	3/L2 (Ref. Vline) 4/T2 (Ref. Vload)	0.25 ...2.5 mm <sup>2</sup> 23...14 AWG	Wire stripped for 8 mm or with tag terminal	0.5 ...0.6 Nm / Flat-head screwdriver tip 0.6 x 3.5 mm

**Note:** Cables must be copper "Stranded Wire" or "Compact-Stranded Wire" type with maximum operating temperature 60/75°C

### SIGNAL CABLES:

<b>J1: Outputs</b> <b>J2, J7: Power supply 24V</b> <b>J5, J6: Control inputs</b>		0,2 - 2,5mm <sup>2</sup>	24 - 14AWG
		0,25 - 2,5mm <sup>2</sup>	23 - 14AWG
<b>J3: Digital inputs</b> <b>J4: Inputs mV / TC AUX</b>		0,14 - 0,5mm <sup>2</sup>	28 - 20AWG
		0,25 - 0,5mm <sup>2</sup>	23 - 20AWG

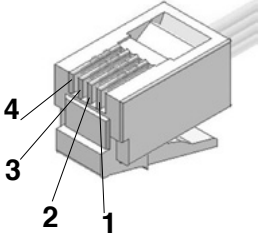
	Connector RJ10 4-4 pin	Nr. Pin	Name	Description	Note
<b>J8, J9: SERIAL RS 485</b>		1	GND1 (**)		(**) Connect the GND signal among Modbus devices with a line distance > 100 m
		2	Tx/Rx+	Data reception/transmission (A+)	
		3	Tx/Rx-	Data reception/transmission (B-)	
		4	+V (reserved)		

**Cable type:** flat telephone cable for pin 4-4 conductor 28AWG

# ELECTRICAL CONNECTIONS for models GFW 400-600A



## POWER CONNECTIONS

### RECOMMENDED WIRE GAUGES

GFW CURRENT LEVEL	TERMINAL	TYPE CABLE / SECTION TYPE RAIL / SECTION	TERMINAL TYPE CABLE / RAIL	TIGHTENING / TOOL TORQUE
400 A	1/L1, 2/T1	Single cable - 300 mm <sup>2</sup> (600Kcmil)	Wire crimped at terminal tube Cembre A60-M12	N. 1 Bolt M12x25mm UNI 5739 hex head wrench n. 18 Pair: 50 Nm
400 A	1/L1, 2/T1	Double cable - 2 x 95 mm <sup>2</sup> (3/0 AWG)	Wire crimped at terminal tube Cembre A19-M10	N. 2 Bolts M10x25mm UNI 5739 hex head wrench n. 17 Pair: 40 Nm
400 A	1/L1, 2/T1	Double cable - 2 x 95 mm <sup>2</sup> (3/0 AWG)	Wire stripped for 30mm inserted in ILSCO AU-350 lug (Accessory)	N. 1 Bolt M12x25mm UNI 5739 hex head wrench n. 18 Pair: 50 Nm (*) see note
400 A	1/L1, 2/T1	Copper rail (W= width, H = height) W = 40 32 24 mm H = 2 2 3 mm	Insulated copper rail with terminal non-insulated for L= 60-65mm max	N. 1 Bolt M12x25mm UNI 5739 hex head wrench n. 18 Pair: 50 Nm
400 A	PE	Cable 95 mm <sup>2</sup> (3/0 AWG)	Wire crimped at terminal tube Cembre A19-M10	N. 1 Bolt M10x20mm UNI 5739 hex head wrench n. 17 Pair: 40 Nm
600 A	1/L1, 2/T1	Double cable - 2 x 185mm <sup>2</sup> (350 Kcmil)	Wire crimped at terminal tube Cembre A37-M10	N. 2 Bolts M10x25mm UNI 5739 hex head wrench n. 17 Pair: 40 Nm
600 A	1/L1, 2/T1	Double cable - 2 x 185mm <sup>2</sup> (350 Kcmil)	Wire stripped for 30mm inserted in ILSCO AU-350 lug (Accessory)	N.1 Bolt M12x25mm UNI 5739 hex head wrench n. 18 Pair: 50 Nm (*) see note
600 A	1/L1, 2/T1	Copper rail (W= width, H = height) W = 50 40 32 mm H = 4 4 5 mm	Insulated copper rail with terminal non-insulated for L= 60-65mm max	N.1 Bolt M12x25mm UNI 5739 hex head wrench n. 18 Pair: 50 Nm
600 A	PE	Cable 185mm <sup>2</sup> (350 Kcmil)	Wire crimped at terminal tube Cembre A37-M10	N. 1 Bolt M10x20mm UNI 5739 hex head wrench n. 17 Pair: 40 Nm
400 A / 600 A	J6, J7	Cavo 0,25...2,5 mm <sup>2</sup> (23...14 AWG)	Wire stripped for 8 mm or with tag terminal	0.6 ...0.6 Nm / Flat-head screwdriver tip 0.6 x 3.5 mm

(\*) NOTE: Wires on the ILSCO accessory must be tightened with a hex head wrench n. 8. Torque: 30 Nm.

### SIGNAL CABLES:

<b>J1: Auxiliary outputs</b> <b>J2: Relay output</b> <b>J3: Supply 24V and digital inputs</b> <b>J4: Analog control inputs</b> <b>J5: CT external inputs</b> <b>J6: V-line connector</b> <b>J7: V-load connector</b>		0,2 - 2,5mm <sup>2</sup>	24 - 14AWG
		0,25 - 2,5mm <sup>2</sup>	23 - 14AWG

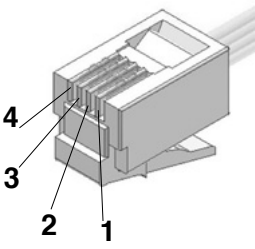
	Connector RJ10 4-4 pin	Nr. Pin	Name	Description	Note
<b>J8, J9: SERIAL RS 485 (PORT1)</b> 		1	GND1 (**)		(**) Connect the GND signal among Modbus devices with a line distance > 100 m
		2	Tx/Rx+	Data reception/transmission (A+)	
		3	Tx/Rx-	Data reception/transmission (B-)	
		4	+V (reserved)		

**Cable type:** flat telephone cable for pin 4-4 conductor 28AWG

# ORDER CODE

GFW -

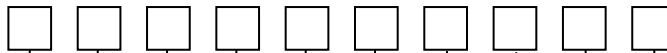

Models	
Single-phase module (Master)	<b>1PH</b>
Bi-phase module (Master + no. 1 expansion)	<b>2PH</b>
Three-phase module (Master + no. 2 expansions)	<b>3PH</b>

Nominal Current	
40Ampere	<b>40</b>
60Ampere	<b>60</b>
100Ampere	<b>100</b>
150Ampere	<b>150</b>
200Ampere	<b>200</b>
250Ampere	<b>250</b>
400Ampere	<b>400</b>
600Ampere	<b>600</b>

Nominal Voltage	
480 Vac (*)	<b>480</b>
600 Vac (*)	<b>600</b>
690 Vac	<b>690</b>

PID Optional Temperature	
Absent	<b>0</b>
TC/RTD/Linear input + PID (*)	<b>1</b>

Auxiliaries Inputs	
Absent	<b>0</b>
4 TC/linear input (60mV) (*)	<b>1</b>

Control options	
Absent	<b>0</b>
Current limit	<b>1</b>
Current limit and feedback V,I,P	<b>2</b>
Current limit and feedback V,I,P + Vload input	<b>3</b>
Current limit and feedback V,I,P + Vload input; CT external inputs (**)	<b>4</b>

FIELDBUS Port 2 opt.	
<b>0</b>	Absent
<b>M</b>	Modbus RTU
<b>P</b>	Profibus DP
<b>C</b>	CANopen (***)
<b>E</b>	Ethernet Modbus TCP
<b>E1</b>	Ethernet IP (***)
<b>E2</b>	EtherCAT
<b>E4</b>	PROFINET

Fuses	
<b>0</b>	Absent
<b>1</b>	Self-contained

Diagnostics Alarms Options	
<b>0</b>	Absent
<b>1</b>	Partial or total load failure alarm. (HB) + diagnostic alarms

Auxiliary Output optional	
<b>0</b>	Absent
<b>R</b>	4 Relays
<b>D</b>	4 Digital outputs
<b>C</b>	4 Direct analogue outputs (*)
<b>T</b>	4 Triac outputs (*)
<b>W</b>	3 analogue outputs 12 bit 0-10 V; 4-20 mA (**)

## NOTES

- (\*) Option NOT available for models with rated current  $\geq 400$  A
- (\*\*) Option NOT available for models with rated current  $\leq 250$  A
- (\*\*\*) Option available as of 4Q\_2017 for models with rated current  $\geq 400$ A

## ACCESSORIES

### CONFIGURATION KIT

#### KIT PC USB / RS485 o TTL



Configuration/supervision kit for GFW by means of PC with USB (Windows environment). Lets you read or write all of the parameters of a single GFW. A single software for all models

- Easy and rapid configuration
- Saving and management of parameter recipes
- On-line trend and saving of historical data

Component Kit:

- Connection cable PC USB <----> GFW RS485 port
- Serial line converter
- CD SW GF Express installation

#### ORDERING CODE

GF\_eXK-2-0-0

Cod. F049095



The human/machine interface (HMI) is simple, intuitive, and very practical thanks to the optional GFW – OP programming keyboard.

Lets you read or write all of the parameters of a single GFW-M module.

Connected with 9-pin D-SUB connector and housed in the front panel of the GFW-M by means of a magnetic plate.

- Alphameric display: 5 lines x 21 characters.
- Keys to display variable and set parameters.
- Magnetic housing

#### ORDERING CODE

GFW - OP

Cod. F068952



Kit for 400/600A wiring with stripped wires (with this kit, wires with crimped terminal tube are not required), consisting of:

- 2 ILSCO lugs
- 2 M12x25 bolts
- 2 Belleville washers
- 2 IP20 protection grids for GFW400/600

#### ORDERING CODE

ILSCO Lug Kit

Cod. F067432

## FUSES

Model	EXTRARAPID FUSES			
	Size I <sup>2</sup> t	Code Format	Model Code	Power Dissipated @ In
GFW 40	80A 2500A <sup>2</sup> s	FUS-080S	DN000UB69V80 338933	5 W
GFW 60	125A 8900A <sup>2</sup> s	FUS-125S	DN000UB69V125 338934	6 W
GFW 100	160A 16000A <sup>2</sup> s	FUS-160S	DN000UB69V160 338935	12 W
GFW 150	200A 31500A <sup>2</sup> s	FUS-200S	DN000UB69V200 338930	19 W
GFW 200/250/480/600V	450A 196000A <sup>2</sup> s	FUS-450S	DN00UB60V450L 338932	17 W
GFW 200/250/690V	400A 150000A <sup>2</sup> s	FUS-400S	DN00UB69V400L 338936	20 W
GFW 400	1000A 970000A <sup>2</sup> s	FUS-1000	PC33UD69V1000TF 338160	40 W
GFW 600	1000A 970000A <sup>2</sup> s	FUS-1000	PC33UD69V1000TF 338160	60 W



## • WARNINGS



**WARNING:** this symbol indicates danger.

**Before installation, please read the following advices:**

- Follow the indications of the manual scrupulously when making the connections to the product
- Use a cable that is suitable for the ratings of voltage and current indicated in the technical specifications.
- If the instrument is used in applications where there is risk of injury to persons and damage to machines or materials, it is essential that it is used with an auxiliary alarm device.  
It is advisable to verify frequently that the alarm device is functional even during the normal operation of the equipment.
- The product must not be used in environments where there could be the presence of dangerous atmospheres (inflammable or explosive).
- During continuous operation, the heatsink may reach 100°C and remain at a high temperature due to thermal inertia even after the device is switched off.  
Therefore, do not touch the heat sink or the electrical wires.
- Do not operate on the power circuit unless the main supply is disconnected.
- Do not open the cover if device is "on"!

**Installation:**

- Connect the device to the ground using the proper ground terminal.
- The power supply wiring must be kept separate from that of inputs and outputs of the instrument; always check that the supply voltage corresponds to that indicated on the instrument cover.
- Delete this line entirely.
- Keep away from dust, humidity, corrosive gases and heat sources.

**Maintenance:** Check the correct operation of the cooling fans at regular intervals; clean the ventilation air filters of the installation at regular intervals.

- Repairs must be performed only by specialized or appropriately trained personnel. Cut off power to the device before accessing internal parts.
- Do not clean the box with solvents derived from hydrocarbons (trichloroethylene, gasoline, etc.). Using such solvents will compromise the mechanical reliability of the device.

To clean external plastic parts, use a clean cloth wet with ethyl alcohol or water.

**Technical service:** GEFRAN has a technical service department. Defects caused by use not conforming to the instructions are excluded from the warranty

GEFRAN spa reserves the right to make any kind of design or functional modification at any moment without prior notice

<b>CSA</b>	Conformity C/CSA/US CoFC no. <b>70002856</b> (NOTE: GFW 400-600A products are not approved CSA)
<b>CE</b>	This device conforms to European Union Directive 2014/30/EU e 2014/35/EU with reference to generic standards: <b>EN 60947-4-3</b> (product)
<b>UL</b>	Conformity C/UL/US file no. <b>E243386 vol. 1 sez. 5</b> (NOTE: UL pending for GFW 400...600A)
<b>SCCR RMS SYM</b> 100KA / 600V	Short Circuit Current Rating 100KA / 600V according to UL 508 for 100 A, 200 A and 250 A, 480 V and 600 V models only