

Principali applicazioni

- Ovens
- Processing plants for chemical and pharmaceutical industries
- Food processing plants
- Sterilizers, autoclaves, continuous ovens and drying unit ceramics and bricks

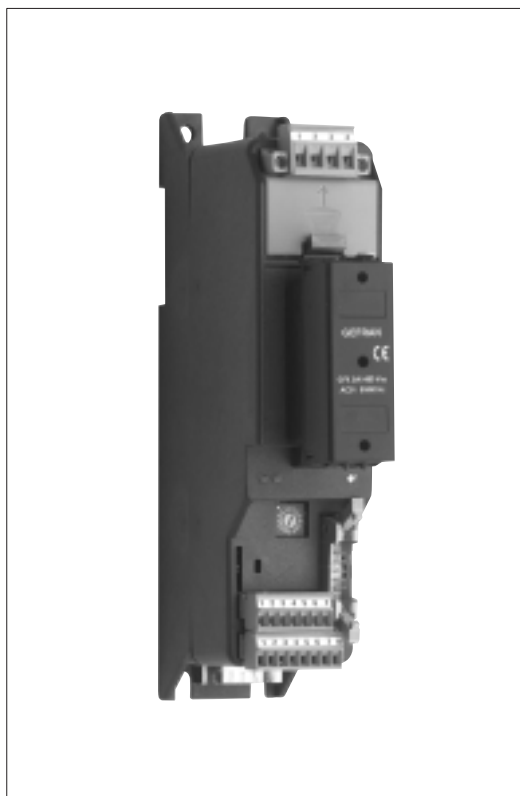

Main features

- Two versions:
MASTER - independent temperature control and communication unit
SLAVE - independent temperature control unit
- Protection: IP20
- Universal temperature input, accuracy 0.2%
- Configurable digital input
- Module with double relay with valve open/close function
- Logic output or "cooling" relay
- Heat/cool PID, selection of cooling fluid, self-tuning, auto-tuning, soft-start
- 4 generic alarms, LBA alarm
- 2 configurable relay outputs
- Field bus for Master
Standard: "Modbus RTU" with Serial 485 optically
Option: "PROFIBUS DP", "CANopen", "DeviceNet"

PROFILE

Rear panel microprocessor instrument for 3-way motorized valves.

The main input for the for the variable to be adjusted is universal, and gives the possibility of connecting various signal types: thermocouples, resistance thermometers, thermistors, linear inputs and potentiometer, all with possibility of custom linearization.

A second isolated auxiliary analog input is available, with fully configurable functions for linear signals or input from potentiometer for valve position. Specific parameters are present for the valve control, such as actuator stroke time, minimum movement time, movement trip setpoint, dead zone. You can also select function type, with or without potentiometer, and with PID or PD algorithm.

Models and communication

The system has high communication capacity and interfaces without limitation with the automation environment. Three standard protocols are available: Modbus RTU, Profibus DP and

CANopen implemented in the Geflex "master", which in turn communicates with up to nine Geflex "slaves" by means of an internal bus.

Mechanics

The mechanical elements have been carefully designed and tested for maximum ease of installation and to guarantee high resistance to vibration and thermal stress.

Diagnostic LEDs

The lower section has three LEDs that indicate the functional state of the main output, ERROR LED, and RUN OK LED.

Temperature input

The temperature input is universal and can be connected to a wide variety of signal types: thermocouples, resistance thermometers, input from 0...60mV, 0...20mA, 0...1Vdc, transmitters, definable only by software, without the need for external adapter shunts. Accuracy of 0.2% guarantees excellent control of the heat process.

Outputs and digital input

The instrument can have up to 3 outputs: a cooling relay (3A, 250V), logic (24Vdc, 35mA) or continuous (0/4...20mA, 0...10V) and two optional alarm relay outputs (3A, 250V). The outputs are freely configurable via software.

By means of internal bus, each "slave" can activate the two relay outputs on the "master" following alarm conditions to create electrical clearance or block signals set to assure safe operation of technological systems.

This further reduces electromechanical wiring.

At the logic level, there are 4 generic alarms configurable as: absolute, deviation, direct, reverse, window, in latching or non-latching mode, disabled at power-up.

With the isolated digital input always available, you can select one of the two pre-settable set points select Manual-Automatic mode, reset the alarms memory, or enable the hold function.

Programming

The Geflex modules can be programmed via a supervisor (industrial PC, HMI) or via the GFX_OP terminal (see accessories). Both solutions provide complete configurability and diagnostics for every Geflex (Master/Slave). For even simpler configuration, a programming kit (from notebook PC or palm PC) is available, composed of an IRDA interface unit and WINSTRUM (a guided program for Windows environment - see technical sheet).

TECHNICAL DATA

INPUTS

Input range: 0...60mV.

Sampling time: 120msec.

Accuracy: 0,2%fs \pm 1 scale points at 25°C.

Resolution : < 2 μ V for range 60mV.

Input filter: 0...20,0sec.

Zero offset adjustable in range:

-999...+999 scale points.

Main input

Thermocouple, Resistance Thermometer, Linear.

Application: process variable.

Thermocouples:

ITS90: J, K, R, S, T, custom.

Cold junction compensation: internal, with automatic compensation.

Resistance Thermometer:

Pt100 DIN 43710, J Pt100, custom.

Linears/Transmitters:

range 0...60mV, 0...20mA, 0...1Vdc (configurable within limits).

Possible 32 segment custom linearization.

Digital input

PNP 24V, 8mA (isol. 3500V)

Applications: Man/Auto, Loc/Rem, Hold, Reset alarms, Select setpoint, shut down software.

Auxiliary input

0/4...20mA (Ri > 50 Ω)

0/2...10V (Ri > 100K Ω)

Potentiometers \geq 1K Ω

OUTPUTS

3 Relays / 1 Logic or 1 Continuous + 2 Relays.

- Relay

NO, max 3A, 250V resistive load.

Application: cooling, alarms.

- Logic

24Vdc, 35mA.

Application: cooling, alarms.

- Continuous

0...10V; 0/4...20mA

Application: cooling, alarms.

- Double relay module

2 Relays, NO contacts, single common. Max. 3A, 250V resistive load.

DIGITAL COMMUNICATION, FIELD BUS

Asynchronous serial transmission.

Standard protocol: MODBUS RTU

RS485 2 wires, 1200...19200 baud.

Optional protocol: CAN OPEN

10K...1M bit/sec, PROFIBUS DP

9,6...12Mbit/sec.

Safety

Detection of short circuit or opening of input probe, open loop alarm (LBA), load fault alarm (HB), overheat SCR.

PROCESS CONTROL FUNCTIONS

Control

PID, PI, PD, P, On/Off, heat, cool, heat + cool with fluid selection.

Manual/Automatic: Bumpless or with manual forcing of output.

Tuning

- Self-tuning: calculation of PID parameters at system start.

- Auto-tuning: continuous adjustment of PID.

Special functions

Soft-start, power limitation, software shut down.

Alarms

Up to 4:

absolute, deviation, symmetric, direct, reverse, latching and non, LBA, HB.

Reference: PV, SP, auxiliary input (for HB).

Multiset

Double setpoint with gradient selectable from digital input

POWER SUPPLY

24Vdc \pm 25%, 5W

DIMENSIONS AND CUTOUT

Base with "Double Relay" module

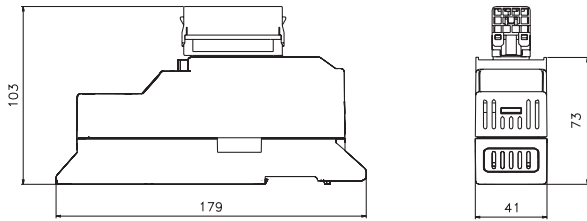

Base
Mounting on electromechanical plate with quick coupling to DIN EN50022 guide or with 5mA screws

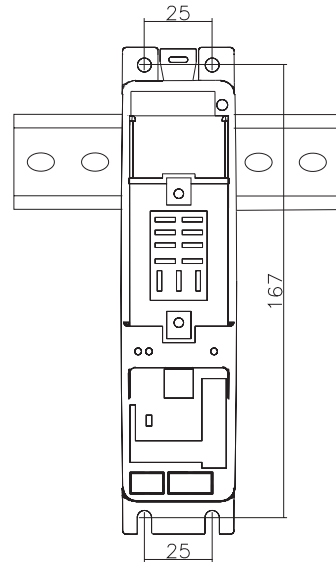

DESCRIPTION OF FACEPLATE

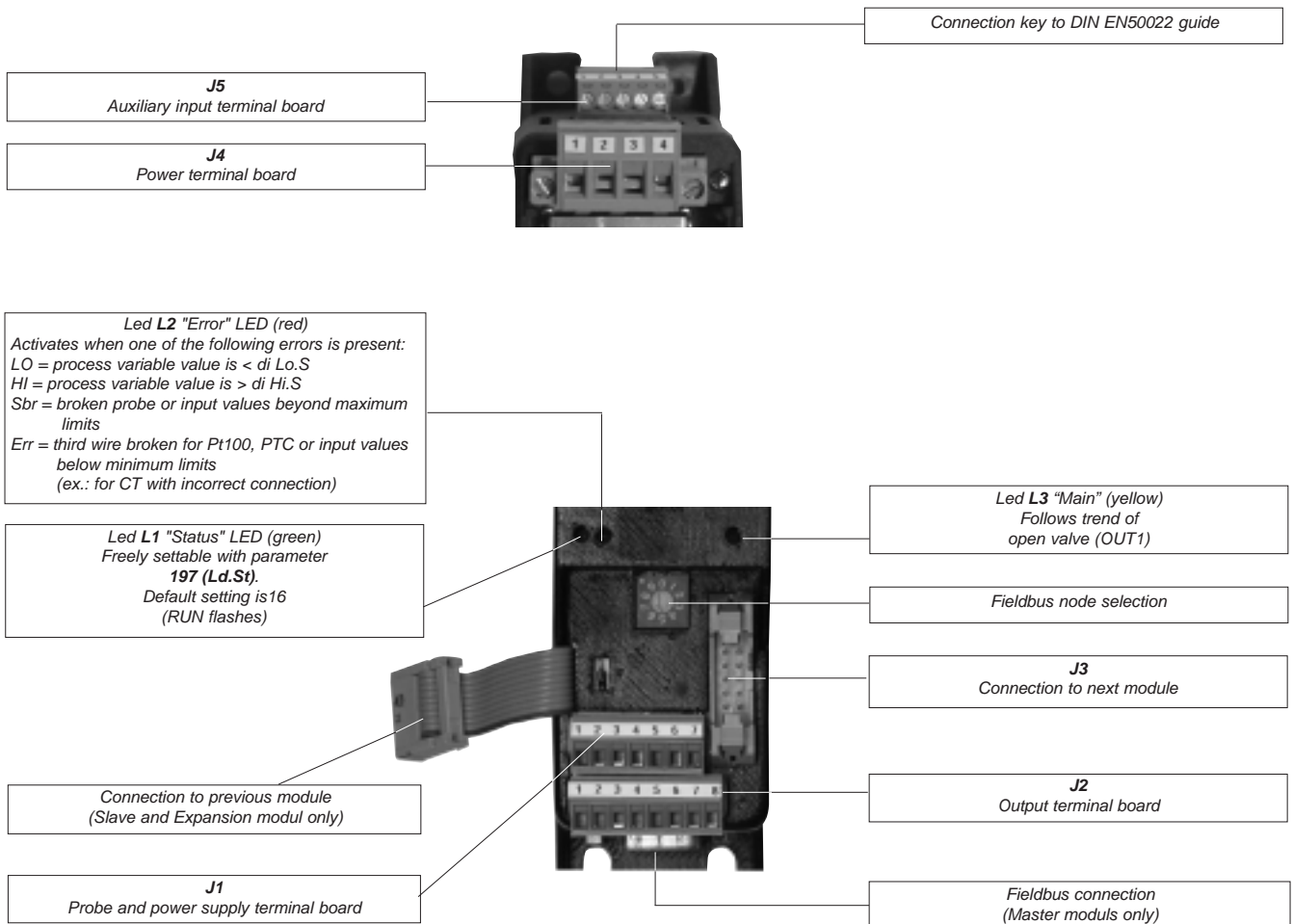

CONNECTION EXAMPLES

Connection of MASTER + SLAVE modules

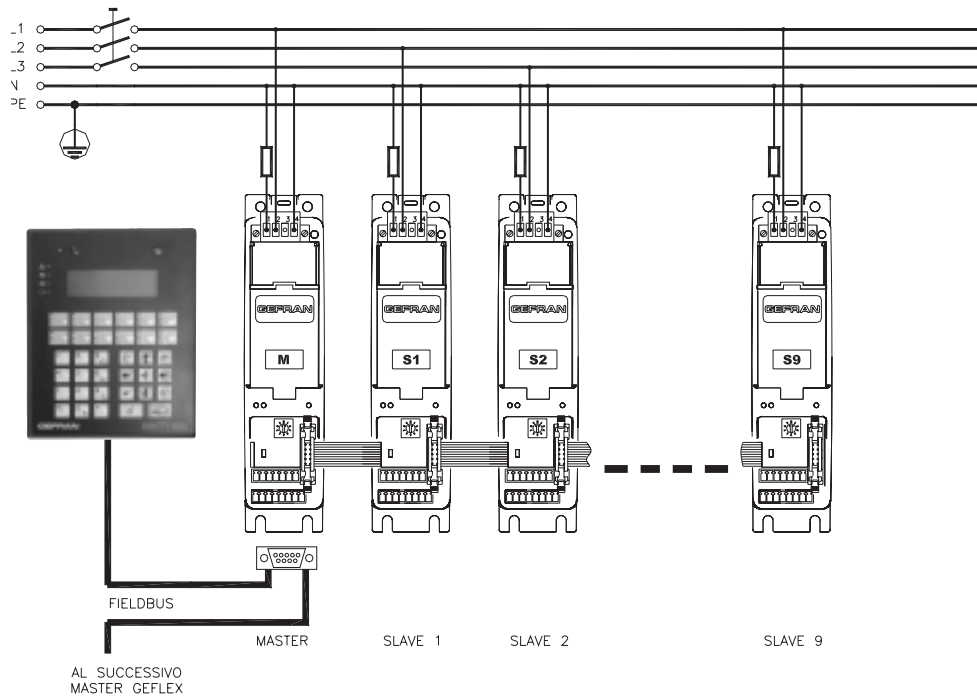
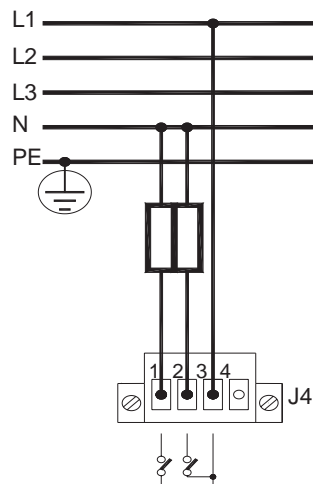

TABLE FOR SELECTION OF WIRE TERMINALS FOR POWER AND SIGNAL TERMINAL BOARDS

	Flexible wire conductor	Conductor with prod terminal with insulating collar
SIGNAL	0,14 - 1,5mm ² / 28-16AWG	0,25 - 0,5mm ² / 24-20AWG
POWER	0,2 - 2,5mm ² / 24-12AWG	0,25 - 2,5mm ² / 24-12AWG
Cross-cut screwdriver, blade 0.4 x 2.5mm		

ELECTRICAL CONNECTIONS

Power connections



Open valve (OUT 1): jumper 1-3
Close valve (OUT 7): jumper 2-3

Double relay module "RR"

Input / Output / Power Supply connections

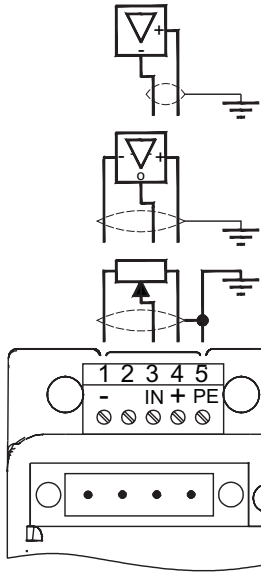

Amplified probe
Current 0...20mA d.c.

Amplified probe
Voltage 0...10V d.c.

Potentiometer
1KΩ...100KΩ

J5

J4

- J1: Probe and power supply terminal board
- J2: Relay output terminal board
- J3: Connection among modules
- J4: Power terminal board
- J5: Aux. input terminal board

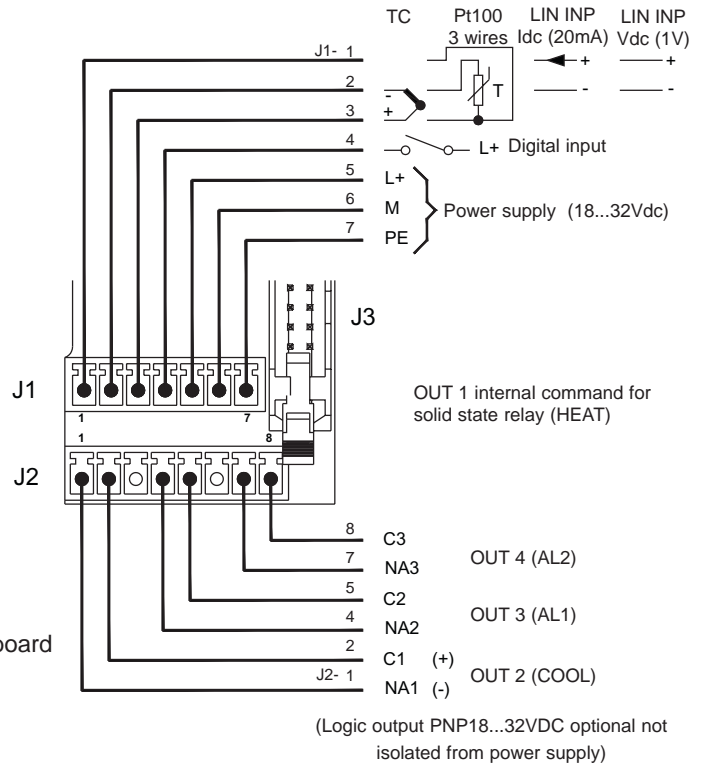

Serial connections

“MODBUS” serial

D-SUB Connector
9-pin Male

Shielded cable 1 pair 22 AWG
MODBUS conformity

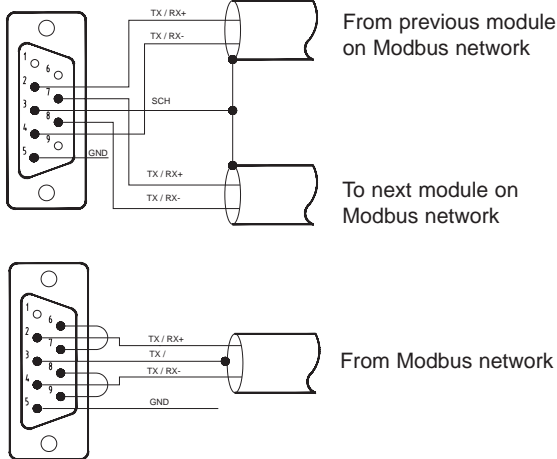

We advise you to connect pins 6 to 7 and pins 8 to 9 on the connector of the last Geflex on the Modbus network to insert the line termination.
It is also advisable to connect the "GND" signal between Modbus devices having a line distance > 100m.

“DeviceNet” serial

Connector 5 pin

Shielded cable 2 pairs 22/24 AWG
DeviceNet conformity

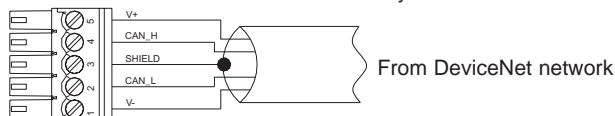

We advise you to connect a 120Ω 1/4W resistance between the "CAN_L" and "CAN_H" signals at both ends of the DeviceNet network.

“PROFIBUS DP” serial

D-SUB connector
9-pin Male

Shielded cable 1 pair 22 AWG
PROFIBUS conformity

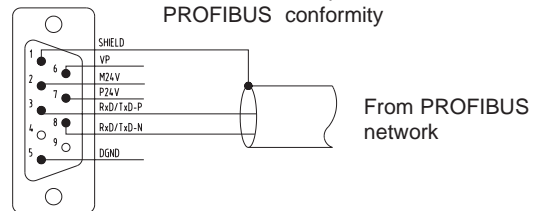

We advise you to connect a 220Ω 1/4W resistance between the "RxD/TxD-P" and "RxD/TxD-N" signals, a 390Ω 1/4W resistance between the "RxD/TxD-P" and "Vp" signals, and a 390Ω 1/4W resistance between the "RxD/TxD-N" and "DGND" signals at both ends of the Profibus network.

“CANopen” serial

D-SUB Connector
9-pin Female

Shielded cable 2 pairs 22/24 AWG
CANopen conformity

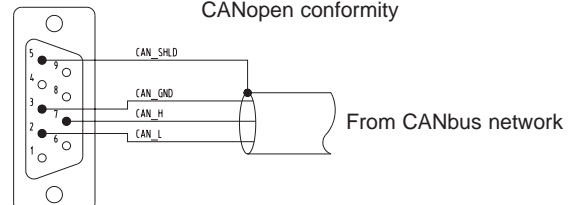

We advise you to connect a 120Ω 1/4W resistance between the "CAN_L" and "CAN_H" signals at both ends of the CANbus network.

ORDER CODE

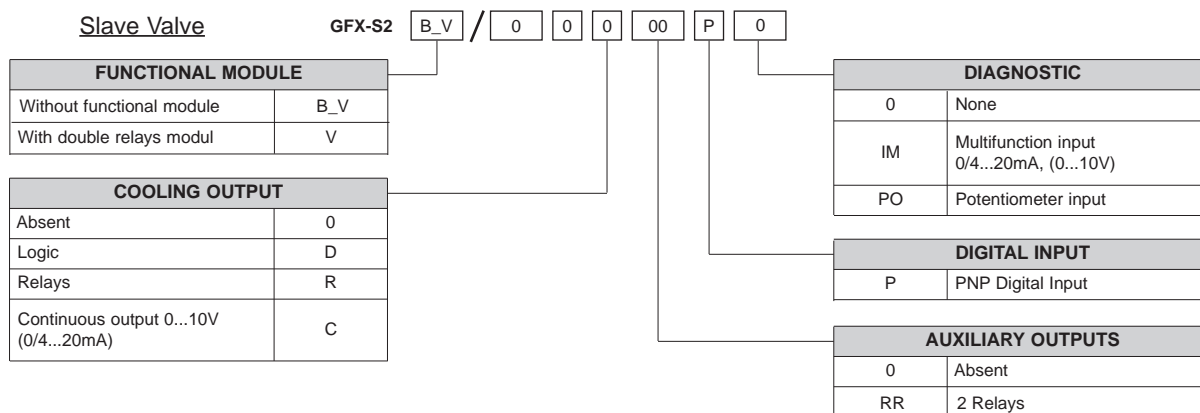
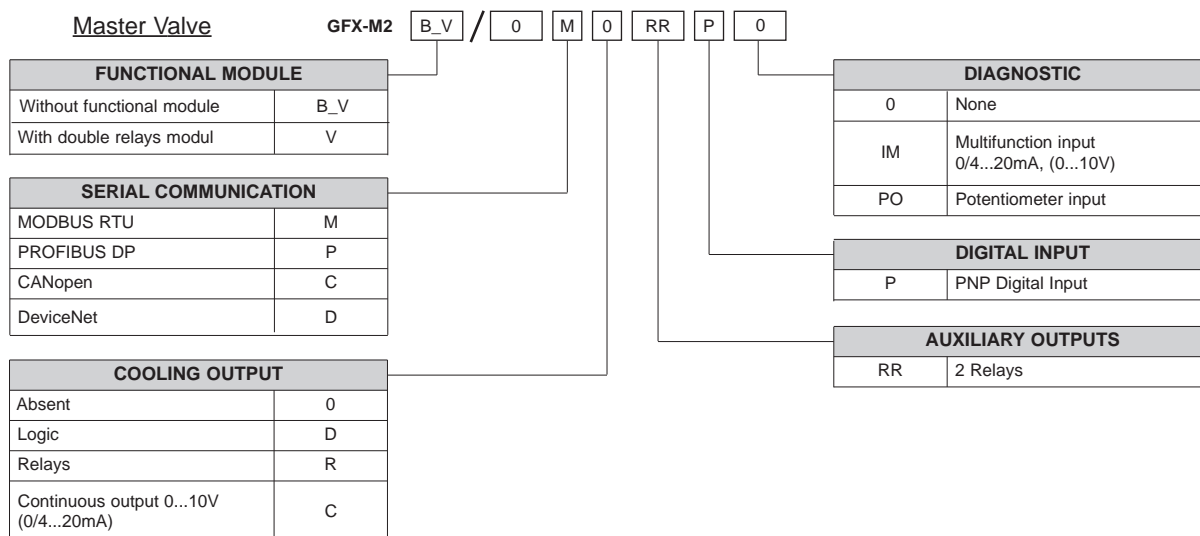

GEFRAN spa reserves the right to make aesthetic or functional changes at any time and without notice.